

# Passaic County Board of Chosen Freeholders

OFFICE OF THE  
PASSAIC COUNTY FREEHOLDERS

Director Pasquale "Pat" Lepore  
Deputy Director Theodore O. Best, Jr.  
John W. Bartlett  
Ronda Casson Cotroneo  
Terry Duffy  
Bruce James  
Hector C. Lora

401 Grand Street  
Paterson, New Jersey 07505  
Tel: 973-881-4402  
Fax: 973-742-3746

Anthony J. De Nova III  
*Administrator*  
William J. Pascrell, III, Esq.  
*County Counsel*  
Louis E. Imhof, III, RMC  
*Clerk Of The Board*



## Public Meeting (Board Meeting)

### Meeting Venue

Date: Mar 25, 2014 - 5:30 PM  
Location: County Administration  
220  
401 Grand Street  
Paterson, NJ 07505

- A. Announcement of the Open Public Meeting Law
- B. Roll Call:
  - 1. Bartlett
  - 2. Cotroneo
  - 3. Duffy
  - 4. James
  - 5. Lora
  - 6. Deputy Director Best
  - 7. Director Lepore
- C. Invocation
- D. Pledge of Allegiance
- E. Moment of silence to remember all the men and women who have died while serving in the United States Armed Forces
- F. Approval of Minutes: March 11, 2014
- G. Approval of Proclamation:

1. Proclamation honoring Lauren Murphy as WE DO President.
2. Proclamation congratulating Eastern Christian Children Retreat on there Open House and Recognizing March As Developmental Disabilities Awareness Month.
3. Proclamation congratulating New Life Christian Evangelistic Church on there Pastoral Anniversary.
4. Congratulating Agape Christian Ministries on there 27th Church Anniversary.

H. Freeholder Reports:

1. Freeholder Director Pat Lepore
2. Freeholder Deputy Director Theodore O. Best, Jr.
3. Freeholder John W. Bartlett
4. Freeholder Ronda Casson Cotroneo
5. Freeholder Terry Duffy
6. Freeholder Bruce James
7. Freeholder Hector C. Lora

I. Communications:

1. March of Dimes, requesting permission to hang a banner in Wayne Township from Monday, April 14, 2014 through Monday, April 28, 2014. The Banner will promote March of Dimes-March of Babies, taking place on Sunday, April 27th at Wayne Hills High School, all as noted in the communication.

J. Oral Portion:

1. Motion to Open the Public Portion of the meeting
2. Motion to Close the Public Portion of the meeting

K. Resolutions - 2/3 Vote

1. TRANSFER RESOLUTION # 7, ALL AS NOTED IN THE RESOLUTION

L. Resolutions - Consent Agenda:

**ADMINISTRATION AND FINANCE**

1. RESOLUTION REAPPOINTING DORIS WHITAKER AND PATRICIA RING AS MEMBERS OF THE CAMP HOPE COMMISSION FOR THE TERM PROVIDED BY LAW, ALL AS NOTED IN THE RESOLUTION

## **ADMINISTRATION AND FINANCE**

2. RESOLUTION AUTHORIZING AWARD OF CONTRACT TO APPLE SPECIALTIES, INC FOR VARIOUS SLOAN LAVATORY/ SHOWER PARTS FOR PASSAIC COUNTY AS PER BID, ALL AS NOTED IN THE RESOLUTION
  
3. RESOLUTION AUTHORIZING AWARD OF CONTRACT TO GRANT SUPPLY CO, INC FOR VARIOUS SLOAN LAVATORY/ SHOWER PARTS FOR PASSAIC COUNTY AS PER BID, ALL AS NOTED IN THE RESOLUTION
  
4. RESOLUTION AUTHORIZING AWARD OF CONTRACT TO PLUMBMASTER, INC FOR VARIOUS SLOAN LAVATORY/ SHOWER PARTS FOR PASSAIC COUNTY AS PER BID, ALL AS NOTED IN THE RESOLUTION
  
5. RESOLUTION TO PURCHASE VIA STATECONTRACT AND COUNTYCOOPERATIVES, ALL AS NOTED IN THE RESOLUTION
  
6. RESOLUTION AUTHORIZING AWARD OF CONTRACT TO AIR SYSTEMS MAINTENANCE INC FOR THE PREVENTATIVE MAINTENANCE FOR AIR COOLED CHILLERS AND SERVICE/REPAIR OF AIR CONDITIONING HEATING AND REFRIGERATION UNITS IN PASSAIC COUNTY BUILDINGS AS PER BID, ALL AS NOTED IN THE RESOLUTION
  
7. RESOLUTION APPOINTING RICHARD P. CAHILL AS CHIEF FINANCIAL OFFICER FOR THE COUNTY OF PASSAIC FOR THE TERM PROVIDED BY LAW, I.E, EFFECTIVE IMMEDIATELY AND TERMINATING ON DECEMBER 31, 2016, ALL AS NOTED IN THE RESOLUTION
  
8. RESOLUTION AUTHORIZING AWARD OF CONTRACT TO SHINDLER ELEVATOR CORP FOR THE SERVICE AND MAINTENANCE OF THIRTY-THREE ELEVATORS IN VARIOUS PASSAIC COUNTY BUILDINGS AS PER BID, ALL AS NOTED IN THE RESOLUTION
  
9. RESOLUTION AUTHORIZING A CONTRACT BETWEEN THE COUNTY PASSAIC AND COST CONTAINMENT EXPRESS OF MEMPHIS, TENNESSEE FOR OUT-OF-NETWORK COST CONTAINMENT SERVICES RELATIVE TO THE COUNTY'S SELF-FUNDED HEALTH BENEFITS PLAN, ALL AS NOTED IN THE RESOLUTION

## **HUMAN SERVICES**

10. RESOLUTION AUTHORIZING THE COUNTY TO ENTER INTO AN AGREEMENT THROUGH A MEMORANDUM OF AGREEMENT FOR A THREE (3) MONTH PERIOD WITH HORIZON NEW JERSEY HEALTH FOR MEDICAID MANAGED CARE COMMENCING JULY 1, 2014 THROUGH SEPTEMBER 30, 2014, ALL AS NOTED IN THE RESOLUTION
  
11. RESOLUTION AUTHORIZING THE PAYMENT TO CERTAIN VENDORS OF THE WEATHERIZATION PROGRAM THAT HAVE BY THEIR EMERGENT NATURE EXCEEDED THE COUNTY'S BID THRESHOLD, ALL AS NOTED IN THE RESOLUTION
  
12. RESOLUTION AUTHORIZING THE FREEHOLDER BOARD TO ENTER INTO A LETTER OF AGREEMENT FOR THREE MONTH EXTENSION FOR ENTERAL NUTRITION SERVICES DURING RFP PROCESS R-11-409, ALL AS NOTED IN THE RESOLUTION
  
13. RESOLUTION AUTHORIZING THE FREEHOLDER BOARD TO ENTER INTO A LETTER OF AGREEMENT FOR THREE MONTH EXTENSION FOR PHARMACY SERVICES DURING RFP PROCESS R-09-50, ALL AS NOTED IN THE RESOLUTION
  
14. RESOLUTION AUTHORIZING THE SUBMISSION OF AN APPLICATION TO NEW JERSEY TRANSIT FOR THREE MINI-BUSES WITH LIFTS TO PROVIDE TRANSPORTATION TO RESIDENTS OF PREAKNESS HEALTHCARE CENTER (SENIOR CITIZENS AND PEOPLE WITH DISABILITIES) UNDER A GRANT, NEW JERSEY TRANSIT FTA, 5310, ALL AS NOTED IN THE RESOLUTION
  
15. RESOLUTION AUTHORIZING THE RE-APPOINTMENTS OF JANICE SANGEL, ANN LONG, LOIS HAMILTON, JOAN LYNKYAK, LINDA WILSON, CINDY SIMON, JUDY GIURINTANO TO THE PASSAIC COUNTY ADVISORY COUNCIL ON DISABILITY FOR A THREE-YEAR TERM, ALL AS NOTED IN THE RESOLUTION
  
16. RESOLUTION AUTHORIZING THE APPOINTMENT OF LORI FRIEDMAN TO THE WORKFORCE INVESTMENT BOARD OF PASSAIC COUNTY FOR A TERM OF THREE (3) YEARS COMMENCING IMMEDIATELY AND TERMINATING MARCH 24, 2017, ALL AS NOTED IN THE RESOLUTION
  
17. RESOLUTION AUTHORIZING THE COUNTY OF PASSAIC TO RE-ENTER INTO A LEASE AGREEMENT WITH THE PASSAIC COUNTY HISTORICAL SOCIETY FOR THE LATTER'S OCCUPANCY OF COUNTY PREMISES LOCATED IN LAMBERT CASTLE, ALL AS NOTED IN THE RESOLUTION



## **HUMAN SERVICES**

18. RESOLUTION AUTHORIZING RESOLUTION REQUEST TO SUBMIT AN APPLICATION FOR THE FOLLOWING AVAILABLE GRANT, "DOE WEATHERIZATION 2013" – GRANT LOAN AGREEMENT IN THE AMOUNT OF \$62,691.00. THIS GRANT AGREEMENT WILL ENABLE THE WEATHERIZATION TO LOW-INCOME FAMILIES AND INDIVIDUALS WHO ARE DEEMED ELIGIBLE. BY WEATHERIZING THE ELIGIBLE UNITS, THIS PROJECT WILL ENSURE ENERGY EFFICIENCY FUEL SAVINGS AND INCREASED COMFORT, ALL AS NOTED IN THE RESOLUTION
  
19. RESOLUTION AUTHORIZING THE AMENDMENT OF RESOLUTION R-14-0193 DATED MARCH 11, 2014 TO CORRECT THE YEAR OF TERM FROM 2017 TO 2016, ALL AS NOTED IN THE RESOLUTION

## **PUBLIC WORKS**

20. RESOLUTION FOR AWARD OF CONTRACT TO ZUCCARO, INC. FOR THE GOFFLE ROAD/ROCK ROAD/BRAEN AVENUE INTERSECTION IMPROVEMENT PROJECT IN THE BOROUGH OF HAWTHORNE, NJ AS PER BID, ALL AS NOTED IN THE RESOLUTION
  
21. RESOLUTION APPROVING PLANS AND SPECIFICATIONS AND AUTHORIZING THE ADVERTISEMENT AND RECEIPT OF BIDS FOR THE PROJECT KNOWN AS THE 2014 LOWER COUNTY ROAD RESURFACING PROJECT IN PATERSON, CLIFTON, PASSAIC, HALEDON AND HAWTHORNE, NEW JERSEY, ALL AS NOTED IN THE RESOLUTION
  
22. RESOLUTION APPROVING PLANS AND SPECIFICATIONS AND AUTHORIZING THE ADVERTISEMENT AND RECEIPT OF BIDS FOR THE PROJECT KNOWN AS THE 2014 UPPER COUNTY ROAD RESURFACING PROJECT IN BLOOMINGDALE, HALEDON, LITTLE FALLS, WANAQUE, WAYNE AND WEST MILFORD, NEW JERSEY, ALL AS NOTED IN THE RESOLUTION
  
23. RESOLUTION APPROVING ROAD OPENING PERMIT TO PSE&G FOR INSTALLATION OF MANHOLES AND DUCT BANK ON RATZER ROAD AT ROCK ROAD IN WAYNE, NJ, ALL AS NOTED IN THE RESOLUTION
  
24. RESOLUTION APPROVING NEGOTIATED PRICE AND EASEMENT RIGHTS FOR PREMISES AT 1128 PREAKNESS AVENUE IN WAYNE, NJ IN CONNECTION WITH THE REPLACEMENT OF THE PREAKNESS AVENUE BRIDGE & CULVERT OVER THE SINGAC BROOK IN THE TOWNSHIP OF WAYNE, NEW JERSEY, ALL AS NOTED IN THE RESOLUTION

## **PUBLIC WORKS**

25. RESOLUTION APPROVING ROAD OPENING PERMIT TO PSE&G FOR INSTALLATION OF MANHOLES AND DUCT BANK ON PATERSON-HAMBURG TURNPIKE AT EASEDALE ROAD IN WAYNE, NJ, ALL AS NOTED IN THE RESOLUTION
  
26. RESOLUTION APPROVING ROAD OPENING REQUEST FOR KEMSCO CONSTRUCTION AND EQUIPMENT CO., INC. TO OPEN SECTIONS OF VAN HOUTEN AVENUE IN CLIFTON, NEW JERSEY, ALL AS NOTED IN THE RESOLUTION
  
27. RESOLUTION APPROVING ROAD OPENING REQUEST FOR KEMSCO CONSTRUCTION AND EQUIPMENT CO., INC. TO OPEN SECTIONS OF MT. PROSPECT AVENUE IN CLIFTON, NEW JERSEY, ALL AS NOTED IN THE RESOLUTION
  
28. RESOLUTION TO AMEND CONTRACT FOR SIMOFF ENGINEERING ASSOCIATES, LLC AS IT CONCERNS THE PREPARATION OF AN EXPERT TRAFFIC ENGINEERING REPORT RELATING TO A CONDEMNATION HEARING FOR PROPERTY AT 777 HAMBURG TURNPIKE IN WAYNE, NJ FOR THE INTERSECTION IMPROVEMENT PROJECT OF THE PATERSON HAMBURG TURNPIKE & VALLEY ROAD INTERSECTION IMPROVEMENT PROJECT IN WAYNE, NJ, ALL AS NOTED IN THE RESOLUTION
  
29. RESOLUTION APPROVING ROAD OPENING REQUEST FOR KEMSCO CONSTRUCTION AND EQUIPMENT CO., INC. TO OPEN SECTIONS OF CLIFTON AVENUE IN CLIFTON, NEW JERSEY, ALL AS NOTED IN THE RESOLUTION
  
30. RESOLUTION TO AWARD CONTRACT TO MONARCH ELECTRIC FOR ELECTRICAL SUPPLIES AND EQUIPMENT PURCHASED FOR PASSAIC COUNTY BUILDINGS, ALL AS NOTED IN THE RESOLUTION
  
31. RESOLUTION FOR CHANGE ORDER #3 FOR SIMPLEX GRINNELL AS IT PERTAINS TO THE PASSAIC COUNTY JAIL NEW FIRE DETECTION/ALARM AND SUPPRESSION PROJECT, PHASE 1, IN PATERSON, NEW JERSEY, ALL AS NOTED IN THE RESOLUTION
  
32. RESOLUTION APPROVING PLANS AND SPECIFICATIONS AND AUTHORIZING THE ADVERTISEMENT AND RECEIPT OF BIDS FOR THE PROJECT KNOWN AS THE PREAKNESS MINERALS PROJECT IN THE BOROUGH OF HALEDON AND TOWNSHIP OF WAYNE, NEW JERSEY, ALL AS NOTED IN THE RESOLUTION

## **PUBLIC WORKS**

33. RESOLUTION APPROVING PLANS AND SPECIFICATIONS AND AUTHORIZING THE ADVERTISEMENT AND RECEIPT OF BIDS FOR THE PROJECT KNOWN AS THE WEST MILFORD SALT STORAGE PROJECT IN THE TOWNSHIP OF WEST MILFORD, NEW JERSEY, ALL AS NOTED IN THE RESOLUTION
  
34. RESOLUTION FOR CHANGE ORDER #6 FOR DRILL CONSTRUCTION CO., INC. AS IT PERTAINS TO THE PASSAIC COUNTY COURT HOUSE COMPLEX ENVELOPE PROJECT AT 71 HAMILTON STREET IN PATERSON, NEW JERSEY, ALL AS NOTED IN THE RESOLUTION
  
35. RESOLUTION DECLARING THAT THE COUNTY OF PASSAIC WISHES TO GO ON RECORD AS URGING THE STATE OF NEW JERSEY LEGISLATURE TO PASS A SUPPLEMENTAL BUDGET APPROPRIATION FOR THE STATE FISCAL YEAR TO REPLACE THE LOSS OF \$5,790,000.00 IN TRANSPORTATION FUNDING, ALL AS NOTED IN THE RESOLUTION
  
36. RESOLUTION AUTHORIZING AWARD OF CONTRACT TO GOLF CHANNEL SOLUTIONS FOR RECEIPT OF REVENUE FOR FOUR TEE TIMES AT THE PREAKNESS VALLEY GOLF COURSE ON A DAILY BASIS FOR A TWO-YEAR PERIOD IN RETURN FOR PROMOTION AND MARKETING SERVICES TO BE PROVIDED FOR THE COURSE, ALL AS NOTED IN THE RESOLUTION
  
37. RESOLUTION FOR CHANGE ORDER #5 TO DRILL CONSTRUCTION CO., INC. AS IT PERTAINS TO THE PASSAIC COUNTY COURT HOUSE COMPLEX ENVELOPE PROJECT AT 71 & 77 HAMILTON STREET IN PATERSON, ALL AS NOTED IN THE RESOLUTION

## **LAW AND PUBLIC SAFETY**

38. RESOLUTION AUTHORIZING THE PASSAIC COUNTY PROSECUTOR'S OFFICE TO APPLY FOR STATE FUNDING UNDER THE VICTIMS OF CRIME ACT GRANT NO. V-16-13 FOR A PROJECT IDENTIFIED AS "COUNTY OFFICE OF VICTIMS WITNESS ADVOCACY", ALL AS NOTED IN THE RESOLUTION
  
39. RESOLUTION AUTHORIZING PURCHASE OF VARIOUS ITEMS BY THE PASSAIC COUNTY PROSECUTOR'S OFFICE, ALL AS NOTED IN THE RESOLUTION

## **LAW AND PUBLIC SAFETY**

40. RESOLUTION AUTHORIZING PURCHASE OF VARIOUS ITEMS BY THE PASSAIC COUNTY OFFICE OF EMERGENCY MANAGEMENT, ALL AS NOTED IN THE RESOLUTION
  
41. RESOLUTION AUTHORIZING THE EXECUTION OF A GRANTEE-SUBGRANTEE AGREEMENT BETWEEN THE COUNTY OF PASSAIC AND THE STATE OF NEW JERSEY OFFICE OF THE ATTORNEY GENERAL DEPARTMENT OF LAW AND PUBLIC SAFETY FOR THE PASSAIC COUNTY MULTI-JURISDICTIONAL HAZARD MITIGATION PLAN UPDATE, ALL AS NOTED IN THE RESOLUTION
  
42. RESOLUTION AUTHORIZING PURCHASE OF MAINTENANCE AND USAGE FOR ALL COPY MACHINES FOR CALENDAR YEAR 2014 THROUGH STATE CONTRACT FOR THE PASSAIC COUNTY SHERIFF'S OFFICE, ALL AS NOTED IN THE RESOLUTION
  
43. RESOLUTION AUTHORIZING PURCHASE OF AUTOMOBILE PARTS FOR THE PASSAIC COUNTY SHERIFF'S VEHICLE FLEET THROUGH STATE CONTRACT, ALL AS NOTED IN THE RESOLUTION
  
44. RESOLUTION AUTHORIZING PURCHASE OF PERSONAL HYGIENE ITEMS FOR THE PASSAIC COUNTY JAIL FROM CHARM TEX , ALL AS NOTED IN THE RESOLUTION
  
45. RESOLUTION AUTHORIZING A CONTRACT WITH RENOVO SOFTWARE OF EDINA, MN, TO PROVIDE COMPUTER SOFTWARE FOR THE OPERATION OF THE INMATE VIDEO VISITATION SYSTEM AT THE PASSAIC COUNTY JAIL, ALL AS NOTED IN THE RESOLUTION

## **PLANNING AND ECONOMIC DEVELOPMENT**

46. RESOLUTION AUTHORIZING AN APPLICATION TO THE NORTH JERSEY TRANSPORTATION PLANNING AUTHORITY (NJPTA), FOR FY-2014, FOR TRANSPORTATION CLEAN AIR MEASURES (TCAM) PROGRAM, IN THE AMOUNT OF \$585,000.00, WITH A 20% LOCAL MATCHING FUNDS, TO CONSTRUCT BICYCLE AND PEDESTRIAN FACILITIES ASSOCIATED WITH MORRIS CANAL GREENWAY PROJECT IN THE CITIES OF PATERSON AND CLIFTON, ALL AS NOTED IN THE RESOLUTION

## **LATE STARTERS**

47. RESOLUTION AUTHORIZING PURCHASE OF REPLACEMENT FURNITURE FOR USE AT THE PREAKNESS VALLEY GOLF COURSE CLUB HOUSE IN TOTOWA, NJ THROUGH STATE CONTRACT VENDOR

M. 12. New Business:

1. Personnel

2. Bills
3. Certification of Payroll
4. Receipt of Departmental Reports

N. 13. Adjournment

# Passaic County Board of Chosen Freeholders

OFFICE OF THE  
PASSAIC COUNTY FREEHOLDERS

Director Pasquale "Pat" Lepore  
Deputy Director Theodore O. Best, Jr.  
John W. Bartlett  
Ronda Casson Cotroneo  
Terry Duffy  
Bruce James  
Hector C. Lora

401 Grand Street  
Paterson, New Jersey 07505

Tel: 973-881-4402  
Fax: 973-742-3746

Anthony J. De Nova III

Administrator

William J. Pascrell, III, Esq.

County Counsel

Louis E. Imhof, III, RMC

Clerk Of The Board



## Public Meeting (Board Meeting)

Date: Mar 25, 2014 - 5:30 PM

Location: County Administration  
220  
401 Grand Street  
Paterson, NJ 07505

Agenda: TRANSFER RESOLUTION # 7, ALL AS NOTED IN THE RESOLUTION

THIS RESOLUTION WAS REQUESTED BY:  
FINANCE DEPARTMENT

REVIEWED BY:

  
Anthony J. De Nova III  
COUNTY ADMINISTRATOR

APPROVED AS TO FORM AND LEGALITY:

  
William J. Pascrell, III, Esq.  
COUNTY COUNSEL

Administration and Finance  
COMMITTEE NAME

<b>Official Resolution#</b>	<b>R20140199</b>						
Meeting Date	03/25/2014						
Introduced Date	03/25/2014						
Adopted Date	03/25/2014						
Agenda Item	k-1						
CAF #							
Purchase Req. #							
Result	Adopted						
<b>FREEHOLDER</b>	<b>PRES.</b>	<b>ABS.</b>	<b>MOVE</b>	<b>SEC</b>	<b>AYE</b>	<b>NAY</b>	<b>ABST.</b>
Lepore	✓				✓		
Best Jr	✓				✓		
Bartlett	✓				✓		
Cotroneo	✓			✓	✓		
Duffy	✓				✓		
James	✓		✓		✓		
Lora	✓				✓		

PRES.= present ABS.= absent  
MOVE= moved SEC= seconded  
AYE= yes NAY= no ABST.= abstain

Dated: March 26, 2014

## COUNTY OF PASSAIC, NEW JERSEY

Resolution Authorizing Transfers Between  
Appropriations # 7

WHEREAS, transfers are permitted between appropriations during the last two months of the fiscal year per N.J.S.A. 40A:4-58 and during the first three months of the succeeding year per N.J.S.A. 40A:4-51, and

WHEREAS, these transfers are effective as of December 31, 2013 and

BE IT RESOLVED, by the Board of Chosen Freeholders of the County of Passaic, in the State of New Jersey by not less than 2/3's vote of the full membership thereof, between 2013 Budget Appropriations as follows:

<u>ACCOUNT</u>	<u>TITLE</u>	<u>FROM</u>	<u>TO</u>
	<u>Finance</u>		
3-01-20-103-001-105	Salary & Wage	10,000.00	
	<u>County Counsel</u>		
3-01-20-104-001-101	Salary & Wage	7,000.00	
	<u>Ethics Board</u>		
3-01-20-104-002-L03	Other Expenses	5,000.00	
	<u>County Adjuster</u>		
3-01-20-104-003-101	Salary & Wage	7,000.00	
	<u>County Register</u>		
3-01-20-108-001-105	Salary & Wage	15,000.00	
	<u>Building &amp; Grounds</u>		
3-01-20-112-001-105	Salary & Wage	5,000.00	
	<u>Medical Examiner</u>		
3-01-22-137-001-213	Other Expenses	150,000.00	
	<u>Board of Election</u>		
3-01-22-139-001-101	Salary & Wage	5,000.00	
	<u>Supt of Elections</u>		
3-01-22-141-001-219	Other Expenses	10,000.00	
3-01-22-141-001-229	Other Expenses	100,000.00	
3-01-22-141-001-E01	Other Expenses	30,000.00	
	<u>Elections County Clerk</u>		
3-01-22-143-001-E01	Other Expenses	50,000.00	
	<u>Planning Board</u>		
3-01-22-147-001-101	Salary & Wage	15,000.00	

	<u>Roads &amp; Bridges</u>	
3-01-26-151-001-213	Other Expenses	30,000.00
3-01-26-151-001-L04	Other Expenses	20,000.00
3-01-26-151-001-R03	Other Expenses	100,000.00
	<u>Engineering</u>	
3-01-26-153-001-101	Salary & Wage	10,000.00
	<u>Department of Youth Services</u>	
3-01-27-170-001-217	Other Expenses	50,000.00
	<u>Preakness Hospital</u>	
3-01-27-172-001-101	Salary & Wage	20,000.00
	<u>Adult Day Care</u>	
3-01-27-176-002-101	Salary & Wage	45,000.00
	<u>County Health Dept</u>	
3-01-27-180-001-101	Salary & Wage	10,000.00
	<u>Parks</u>	
3-01-28-198-001-101	Salary & Wage	15,000.00
	<u>Golf Course</u>	
3-01-28-198-002-101	Salary & Wage	70,000.00
	<u>Supt of Schools</u>	
3-01-29-190-001-101	Salary & Wage	18,000.00
	<u>Police Academy</u>	
3-01-30-206-001-101	Salary & Wage	5,000.00
	<u>Gasoline</u>	
3-01-31-220-001-U02	Other Expenses	100,000.00
	<u>Natural Gas</u>	
3-01-31-222-001-U02	Other Expenses	200,000.00
3-01-31-222-001-U03	Other Expenses	100,000.00
	<u>Heating Oil</u>	
3-01-31-223-001-U02	Other Expenses	25,000.00
	<u>Water</u>	
3-01-31-224-001-U02	Other Expenses	125,000.00
3-01-31-224-001-U03	Other Expenses	25,000.00
	<u>Garbage</u>	
3-01-31-225-001-U02	Other Expenses	125,000.00



	<u>Finance</u>	
3-01-20-103-001-233	Other Expenses	5,000.00
	<u>Audit Fees</u>	
3-01-20-103-003-233	Other Expenses	5,000.00
	<u>Payroll &amp; Bank Processing Fees</u>	
3-01-20-103-006-213	Other Expenses	10,000.00
	<u>Group Hospitalization</u>	
3-01-20-120-001-C02	Other Expenses	20,000.00
	<u>Liability Insurance</u>	
3-01-20-120-006-I01	Other Expenses	1,032,000.00
	<u>Supt of Elections</u>	
3-01-22-141-001-101	Salary & Wage	330,000.00
	<u>Main of Patients</u>	
3-01-27-164-001-M01	Other Expenses	80,000.00
	<u>Reimbursement 2YR College</u>	
3-01-29-196-002-217	Other Expenses	20,000.00
		<u>1,502,000.00</u>
		<u>1,502,000.00</u>

March 25, 2014

This resolution was requested by:  
Richard Cahill  
CHIEF FINANCIAL OFFICER

# Passaic County Board of Chosen Freeholders

OFFICE OF THE  
PASSAIC COUNTY FREEHOLDERS

Director Pasquale "Pat" Lepore  
Deputy Director Theodore O. Best, Jr.  
John W. Bartlett  
Ronda Casson Cotroneo  
Terry Duffy  
Bruce James  
Hector C. Lora

401 Grand Street  
Paterson, New Jersey 07505

Tel: 973-881-4402  
Fax: 973-742-3746

Anthony J. De Nova III

Administrator

William J. Pascrell, III, Esq.

County Counsel

Louis E. Imhof, III, RMC

Clerk Of The Board



## Public Meeting (Board Meeting)

Date: Mar 25, 2014 - 5:30 PM

Location: County Administration  
220  
401 Grand Street  
Paterson, NJ 07505

Agenda: RESOLUTION REAPPOINTING DORIS WHITAKER AND PATRICIA RING AS MEMBERS OF THE CAMP HOPE COMMISSION FOR THE TERM PROVIDED BY LAW, ALL AS NOTED IN THE RESOLUTION

THIS RESOLUTION WAS REQUESTED BY:

REVIEWED BY:

Anthony J. De Nova III  
COUNTY ADMINISTRATOR

APPROVED AS TO FORM AND LEGALITY:

William J. Pascrell, III, Esq.  
COUNTY COUNSEL

Administration and Finance

COMMITTEE NAME

<b>Official Resolution#</b>	<b>R20140200</b>						
Meeting Date	03/25/2014						
Introduced Date	03/25/2014						
Adopted Date	03/25/2014						
Agenda Item	I-1						
CAF #							
Purchase Req. #							
Result	Adopted						
<b>FREEHOLDER</b>	<b>PRES.</b>	<b>ABS.</b>	<b>MOVE</b>	<b>SEC</b>	<b>AYE</b>	<b>NAY</b>	<b>ABST.</b>
Lepore	✓				✓		
Best Jr	✓		✓		✓		
Bartlett	✓			✓	✓		
Cotroneo	✓				✓		
Duffy	✓				✓		
James	✓				✓		
Lora	✓				✓		

PRES.= present ABS.= absent  
MOVE= moved SEC= seconded  
AYE= yes NAY= no ABST.= abstain

Dated: March 26, 2014

**RESOLUTION REAPPOINTING DORIS WHITAKER AND  
PATRICIA RING AS MEMBERS OF THE CAMP HOPE  
COMMISSION FOR THE TERM PROVIDED BY LAW**

**WHEREAS** the Board of Chosen Freeholders of the County of Passaic (the “Board”) is vested by N.J.S.A. 40:23-6.4 with the power to appoint members of the Camp Hope Commission (the “Commission”) for terms of five (5) years; and

**WHEREAS** the Board previously adopted a resolution (R-08-22, 01/03/08) reappointing Doris Whitaker as a member of the Camp Hope Commission for a term commencing of even date therewith and terminating on December 31, 2012; and

**WHEREAS** the Board also previously adopted resolutions (R-09-1059, 12/22/09, corrected by R-10-948, 12/30/10) appointing Patricia Ring as a member of the Camp Hope Commission for a term commencing of even date therewith and terminating on December 31, 2013; and

**WHEREAS** Ms. Whitaker and Ms. Ring have continued to serve as members of the Commission in a holdover capacity since the expiration of their respective terms, in accordance with applicable law; and

**WHEREAS** the Board is desirous of reappointing Mr. Whitaker and Ms. Ring as members of the Commission for the term provided by law, i.e. effective immediately and terminating on December 31, 2017 (as to Ms. Whitaker) and December 31, 2018 (as to Ms. Ring); and

**WHEREAS** the Administration, Finance and Personnel Committee considered this matter at its meeting of March 12, 2014 and recommended this resolution to the full Board for approval;

**NOW THEREFORE BE IT RESOLVED** by the Board of Chosen Freeholders of the County of Passaic that, in accordance with the provisions of N.J.S.A. 40:23-6.4, Doris Whitaker and Patricia Ring be and hereby are reappointed as members of the Camp Hope Commission for the term provided by law, effective immediately and terminating on December 31, 2017 (as to Mr. Whitaker) and December 31, 2018 (as to Ms. Ring).

Dated: March 25, 2014

# Passaic County Board of Chosen Freeholders

OFFICE OF THE  
PASSAIC COUNTY FREEHOLDERS

Director Pasquale "Pat" Lepore  
Deputy Director Theodore O. Best, Jr.  
John W. Bartlett  
Ronda Casson Cotroneo  
Terry Duffy  
Bruce James  
Hector C. Lora

401 Grand Street  
Paterson, New Jersey 07505

Tel: 973-881-4402  
Fax: 973-742-3746

Anthony J. De Nova III

Administrator

William J. Pascrell, III, Esq.

County Counsel

Louis E. Imhof, III, RMC

Clerk Of The Board



## Public Meeting (Board Meeting)

Date: Mar 25, 2014 - 5:30 PM

Location: County Administration  
220  
401 Grand Street  
Paterson, NJ 07505

Agenda:

RESOLUTION AUTHORIZING AWARD OF CONTRACT TO APPLE SPECIALTIES, INC FOR VARIOUS SLOAN LAVATORY/ SHOWER PARTS FOR PASSAIC COUNTY AS PER BID, ALL AS NOTED IN THE RESOLUTION

THIS RESOLUTION WAS REQUESTED BY:

SHERIFF'S DEPT

REVIEWED BY:

Anthony J. De Nova III  
COUNTY ADMINISTRATOR

APPROVED AS TO FORM AND LEGALITY:

William J. Pascrell, III, Esq.  
COUNTY COUNSEL

Administration and Finance

COMMITTEE NAME

Official Resolution#	R20140201						
Meeting Date	03/25/2014						
Introduced Date	03/25/2014						
Adopted Date	03/25/2014						
Agenda Item	I-2						
CAF #	Various						
Purchase Req. #	TBD						
Result	Adopted						
FREEHOLDER	PRES.	ABS.	MOVE	SEC	AYE	NAY	ABST.
Lepore	✓				✓		
Best Jr	✓		✓		✓		
Bartlett	✓			✓	✓		
Cotroneo	✓				✓		
Duffy	✓				✓		
James	✓				✓		
Lora	✓				✓		

PRES.= present ABS.= absent  
MOVE= moved SEC= seconded  
AYE= yes NAY= no ABST.= abstain

Dated: March 26, 2014

**RESOLUTION AUTHORIZING AWARD OF CONTRACT TO APPLE SPECIALTIES, INC FOR VARIOUS SLOAN LAVATORY/ SHOWER PARTS FOR PASSAIC COUNTY AS PER BID**

**WHEREAS**, there exists a need for various Sloan lavatory and shower parts in Passaic County buildings; and

**WHEREAS**, the County of Passaic issued a public solicitation to qualified vendors for 2014 Various Sloan Lavatory/Shower Parts for the County of Passaic in accordance with "Fair and Open" procedures as established in the "Pay-to-Play" Law, N.J.S.A. 19:44A-20.4, et seq.; and

**WHEREAS**, the County of Passaic, Department of Purchasing has reviewed and tabulated the proposals/bids as received on February 27, 2014 pursuant to N.J.S.A. 40A: 11-1 et. seq., and has made a recommendation to the Board of Chosen Freeholders for a contract award to Apple Specialties Inc. of Wading River, NY; and

**WHEREAS**, the Finance, Administration and Personnel Committee has reviewed this matter at its March 12, 2014 meeting and recommends this resolution to the full Board of adoption; and

**WHEREAS**, the contract period will be from April 1, 2014 through March 31, 2015 for an estimated price of \$810.00, for line item #14; and

**WHEREAS**, a certificate is attached hereto, indicating that funds are available in various budget accounts for the within contemplated expenditure; and

**NOW THEREFORE BE IT RESOLVED** by the Board of Chosen Freeholders of the County of Passaic that pursuant to the terms and conditions set forth above, it hereby authorizes an award of contract to Apple Specialties Inc. of Wading River, NY for the products referenced above in an amount not to exceed \$810.00; and

**BE IT FURTHER RESOLVED** that the Clerk of the Board, the Purchasing Agent and the Director of the Board are hereby authorized to execute all necessary agreements on behalf of the County of Passaic as prepared by the Office of County Counsel for said purpose.

CERTIFICATION OF AVAILABLE FUNDS

THIS IS TO CERTIFY THAT FUNDS ARE AVAILABLE AS FOLLOWS:

AMOUNT: \$810.00

APPROPRIATION: Various

PURPOSE: To award a contract to Apple Specialties, Inc. for various Sloan Lavatory/Shower Parts for Passaic County.

  
Michael Katz, County Treasurer

DATED: February 25, 2014



## County of Passaic

Procurement Center  
495 River Street, Paterson, NJ 07524

Michael Marinello, QPA, CCPO  
*Purchasing Agent*

[mmarinello@passaiccountynj.org](mailto:mmarinello@passaiccountynj.org)  
[www.passaiccountynj.org](http://www.passaiccountynj.org)  
Tel: (973) 247-3301  
Fax: (973) 279-6234

March 18<sup>th</sup>, 2014

Board of Chosen Freeholders  
Administration Building

Re: Various Sloan Lavatory & Shower Parts for Passaic County Buildings

Contract Period: April 1, 2014 through March 31, 2015

ATTN: Lou Imhof, Clerk to the Board

Dear Mr. Imhof:

Bids were received at 10:30 am, on February 27, 2014 in the Passaic County Procurement Center. The bids were received and read aloud as follows:

Atlantic Plumbing Supply	Bid 18 items - \$26,760.75
Plumbmaster Inc	Bid 18 items - \$26,166.43
Grant Supply Co, Inc.	Bid 18 items - \$25,928.14
Apple Specialties Inc.	Bid 18 items - \$26,286.69

This was solicited in a Fair and Open Process. Bids were received and evaluated by Deputy Warden Elbrus Basmouk of the Passaic County Sheriff's Department, and it is his recommendation that a contract be awarded per the attached memo. This bid was evaluated on the basis of the vendor bidding the lowest responsible price.

Sincerely,

Michael Marinello, QPA, CCPO

Purchasing Agent



# Deputy Warden Elbrus Basmouk



11 Sheriff's Plaza  
Paterson, NJ 07501

To: Michael Marinello, RPPS, County Purchasing Agent

From: Deputy Warden Elbrus Basmouk

Date: March 7, 2014

RE: 2014 Various Sloan Lavatory/Shower Parts Award Spreadsheet for the PC Jail  
Contract Period: April 1, 2014 to March 31, 2015

I have reviewed the bids proposed by Grant Supply Co. Inc., Apple Specialties Inc., and Plumbmaster Inc. Therefore, I recommend the following line item bids be awarded as follows (as they are the lowest responsive bids per line item);

**Grant Supply Co.,Inc. (\$22326.14) #1 \$1452.00 #2 \$1388.16 #3 \$3557.52 #4 \$2209.44 #5 \$2979.70 #6 \$2243.52 #7 \$1071.60 #8 \$2271.72 #9 \$691.08 #10 \$630.00 #11 \$579.60 #12 \$583.80 #13 \$1239.25 #15 897.60 #16 195.36 #18 335.79**

Grant Supply total: **(\$22326.14)**

**Apple Specialties Inc. #14 810.00**

Apple Specialties total: **(\$810.00)**

**Plumbmaster Inc. #17 \$322.00**

Plumbmaster total: **(\$322.00)**

Total of all line item supplies from all respective lowest bidders: (23,458.14)

Respectfully,

Deputy Warden Elbrus A. Basmouk

Introduced on: March 25, 2014  
Adopted on: March 25, 2014  
Official Resolution: R2014027

**SERVE WITH COMPASSION-PROTECT WITH COURAGE**

**COUNTY OF PASSAIC**  
**BID TALLY SHEET**  
Straight Bids

Michael Marinello, R.P.P.S.  
Purchasing Agent  
Jose Santiago, Esq.  
Assistant County Counsel  
*Taken by Attorney*  
*Taken by R.P.P.S.*  
Typed by

William J. Pascrell, III, Esq.  
County Counsel  
Matthew Malfa  
Deputy County Counsel

**PURCHASING DEPARTMENT**

**Bids received at 10:30 a.m. on FEBRUARY 27, 2014** the Passaic County Procurement Center, 495 River Street Second Floor, Paterson, NJ 07524

**SB-14-006 2014 VARIOUS LAVATORY/SHOWER PARTS FOR THE COUNTY OF PASSAIC**

Vendor	Disc. Stm. (Exh. I)	Non-Coll. Aff. (Exh. II)	B.B. C.Ck. Ca. Check (Exh. III)	Con. Of Surety (Exh. IV)	Last Page (Exh. V)	Business Reg. Cert.	Avail to Co-Op	Disc. I/A Iran	Bid Total
TALATECH AMERICASLLC C/O TAHIR JADOON 197 ROUTE 18 SUITE 3000 EAST BRUNSWICK, NJ 08816 732-456-6316									
ATLANTIC PLUMBING SUPPLY C/O RICHARD MURPHY 2810 RT 37 EAST TOMS RIVER, NJ 08753 732-929-8747	X	X	N/A	N/A	X	X	YES	X	<b>(18) ITEMS</b>  <b>\$26,760.75</b>
PLUMMASTER, INC C/O KATIE MANLEY P.O. BOX 850 CONCORDVILLE, PA 19331 800-259-3143	X	X	N/A	N/A	X	X	NO	X	<b>(18) ITEMS</b>  <b>\$26,166.43</b>

**COUNTY OF PASSAIC**  
**BID TALLY SHEET**  
Straight Bids

Michael Marinello, R.P.P.S.  
Purchasing Agent  
Jose Santiago, Esq.  
Assistant County Counsel  
*Taken by Attorney*  
*Taken by R.P.P.S.*  
Typed by

William J. Pascrell, III, Esq.  
County Counsel  
Matthew Malfa  
Deputy County Counsel

**PURCHASING DEPARTMENT**

**Bids received at 10:30 a.m. on FEBRUARY 27, 2014** the Passaic County Procurement Center, 495 River Street Second Floor, Paterson, NJ 07524

**SB-14-006 2014 VARIOUS LAVATORY/SHOWER PARTS FOR THE COUNTY OF PASSAIC**

Vendor	Disc. Stm. (Exh. I)	Non-Coll. Aff. (Exh. II)	B.B. C.Ck. Cs. Check (Exh. III)	Con. Of Surety (Exh. IV)	Last Page (Exh. V)	Business Reg. Cert.	Avail to Co-Op	Disc. I/A Iran	Bid Total
GRANT SUPPLY CO. INC. C/O GLORIA OBERREITER 901 JOYCE KILMER AVE NORTH BRUNSWICK, NJ 08902 732-545-9879	X	X	N/A	N/A	X	X	YES	X	(18) ITEMS \$25,928.14
APPLE SPECIALTIES INC. 2042 NORTH CONTRY RD. WADING RIVER, NY 11792	X	X	N/A	N/A	X	SUBJECT TO REVIEW (NO BRC)	YES	X	(18) ITEMS \$26,286.69

## 2014 Various Sloan Lavatory/Shower Parts Award Spreadsheet for the PCSD

Contract Period: April 1, 2014 to March 31, 2015

Quantities related to the described items below are estimated quantities to be used during the upcoming year. Quantities may be increased or decreased depending upon demand. It is also likely that certain line items may not be ordered.

Note: This is a Straight Bid. Items 1 through 18 will be awarded on a line to line basis

Item	Description	Specification	Quan.	Vendor	Product ID	Unit Price	Total Price	App'd by	Comments
1	Solenoid	Sloan MCR 139 or equal	24	Grant Supply Co., Inc.	Sloan 3375011	60.50	1452.00	EAB	
				Plumbmaster Inc.	Sloan MCR 139	67.00	1608.00		
				Atlantic Plumbing Supply	Sloan 3375011	62.43	1498.32		
				Apple Specialties Inc.	Sloan 3375011	68.17	1636.08		
2	Module	Sloan MCR 115A or equal	24	Grant Supply Co., Inc.	Sloan 0375118	57.84	1388.16	EAB	
				Plumbmaster Inc.	Sloan MCR 115A	64.10	1538.40		
				Atlantic Plumbing Supply	Sloan 0375118	59.69	1432.56		
				Apple Specialties Inc.	Sloan 0375118	65.17	1564.08		
3	Manifold	Sloan MCR 101-A or equal	18	Grant Supply Co., Inc.	Sloan 0375291	197.64	3557.52	EAB	
				Plumbmaster Inc.	Sloan MCR 101-A	218.98	3941.64		
				Atlantic Plumbing Supply	Sloan 0375291	203.94	3670.94		
				Apple Specialties Inc.	Sloan 0375291	222.69	4008.42		
4	Buttons	Sloan MCR 231 or equal	48	Grant Supply Co., Inc.	Sloan 3375000	46.03	2209.44	EAB	
				Plumbmaster Inc.	Sloan MCR 231	51.00	2448.00		
				Atlantic Plumbing Supply	Sloan 3375000	47.50	2280.00		
				Apple Specialties Inc.	Sloan 3375000	51.87	2459.76		MCR-231-D-180
5	Module	MCR 8002-AX-003 Sloan or equal	10	Grant Supply Co., Inc.	Sloan 0375269	297.97	2979.70	EAB	
				Plumbmaster Inc.	Sloan MCR8002-AX-003	330.16	3301.60		
				Atlantic Plumbing Supply	Sloan 0375269	307.47	3074.70		
				Apple Specialties Inc.	Sloan 0375269	333.73	3337.30		MCR-8002A-003
6	Button	Sloan MCR 184-A-9 or equal	24	Grant Supply Co., Inc.	Sloan 0375175	93.48	2243.52	EAB	
				Plumbmaster Inc.	Sloan MCR 184-A-9	103.59	2486.16		
				Atlantic Plumbing Supply	Sloan 0375173	96.46	2315.04		
				Apple Specialties Inc.	Sloan 0375175	105.36	2528.64		
7	Transformer	Sloan MCR 427 or equal	12	Grant Supply Co., Inc.	Sloan 0375297	89.30	1071.60	EAB	
				Plumbmaster Inc.	Sloan MCR 427	98.96	1187.52		
				Atlantic Plumbing Supply	Sloan 0375297	92.15	1105.80		
				Apple Specialties Inc.	Sloan 0375297	100.32	1203.84		
8	Module	Sloan MCR 4004A or equal	12	Grant Supply Co., Inc.	Sloan 0375280	189.31	2271.72	EAB	
				Plumbmaster Inc.	Sloan MCR 4004A	209.77	2517.24		
				Atlantic Plumbing Supply	Sloan 0375327	195.35	2344.20		
				Apple Specialties Inc.	Sloan 0375280	213.18	2558.16		

Introduced on: March 25, 2014  
 Adopted on: March 25, 2014  
 Official Resolution#: R30440204

Item	Description	Specification	Quan.	Vendor	Product ID	Unit Price	Total Price	App'd by	Comments
9	Transformer	Sloan MCR 426 or equal	12	Grant Supply Co., Inc.	Sloan 0375296	57.59	691.08	EAB	
				Plumbmaster Inc.	Sloan MCR 426	63.81	765.72		
				Atlantic Plumbing Supply	Sloan 0375296	59.43	713.16		
				Apple Specialties Inc.	Sloan 0375296	64.89	778.68		
10	Ext. cord	Sloan ETF 1003-108	36	Grant Supply Co., Inc.	Sloan 0365840	17.50	630.00	EAB	
				Plumbmaster inc.	Sloan ETF1003-108	19.40	698.40		
				Atlantic Plumbing Supply	Sloan 0365840	18.06	650.16		
				Apple Specialties Inc.	Sloan 0365840	19.72	709.92		
11	Ext. cord	Sloan ETF 1003-240	20	Grant Supply Co., Inc.	Sloan 0365100	28.98	579.60	EAB	
				Plumbmaster Inc.	Sloan ETF1003-240	32.12	642.40		
				Atlantic Plumbing Supply	Sloan 0365100	30.12	602.40		
				Apple Specialties Inc.	Sloan 0365100	32.88	653.20		
12	Ext. cord	Sloan ETF 1003-600	20	Grant Supply Co., Inc.	Sloan 0365085	29.19	583.80	EAB	
				Plumbmaster Inc.	Sloan ETF1003-600	30.65	613.00		
				Atlantic Plumbing Supply	Sloan 0365085	30.12	602.40		
				Apple Specialties Inc.	Sloan 0365085	32.66	653.20		
13	Valve repair kit	Sloan ETF-370-A	25	Grant Supply Co., Inc.	Sloan 0305849	49.57	1239.25	EAB	
				Plumbmaster Inc.	Sloan ETF-370-A	52.05	1301.25		
				Atlantic Plumbing Supply	Sloan 0305849PK	51.15	1278.75		
				Apple Specialties Inc.	Sloan 0305849	55.86	1396.50		
14	Valve body	for Sloan Model 611 3.5 gpf	25	Grant Supply Co., Inc.	Sloan 3018910	130.72	3268.00		Complete valve only available quote is for hard wired version A143A
				Plumbmaster Inc.	Sloan A143A (0301050)	50.25	1256.25		
				Atlantic Plumbing Supply	Sloan 3018910	134.88	3372.00		
				Apple Specialties Inc.	Sloan 0301004	32.40	810.00	EAB	
15	Repair kit faucet	ETF-1009-A	48	Grant Supply Co., Inc.	Sloan 3305577	18.70	897.60	EAB	
				Plumbmaster Inc.	Sloan ETF-1009-A	19.99	959.52		PM# 32885
				Atlantic Plumbing Supply	Sloan 3305577	19.31	926.88		
				Apple Specialties Inc.	Sloan 3305577	21.09	1012.32		
16	Ext. cord push button	3EPU9 (C70A)	48	Grant Supply Co., Inc.	Sloan 3303398	4.07	195.36	EAB	
				Plumbmaster Inc.	C70A (3303398)	4.31	206.88		quote is a repair kit
				Atlantic Plumbing Supply	Sloan 3303398	4.20	201.60		
				Apple Specialties Inc.	Sloan 3303398	4.58	219.84		
17	Diaphragm	A156A	100	Grant Supply Co., Inc.	Sloan 5301188	3.34	334.00		
				Plumbmaster Inc.	Sloan A156A	3.22	322.00	EAB	PM# 70629
				Atlantic Plumbing Supply	Sloan 5301188	3.45	345.00		
				Apple Specialties Inc.	Sloan 5301188	3.48	348.00		
	Introduced on:	March 25, 2014							
	Adopted on:	March 25, 2014							
	Official Resolution#	R20140201							

Item	Description	Specification	Quan.	Vendor	Product ID	Unit Price	Total Price	App'd by	Comments
1B	Toilet	MCR 1001A	3	Grant Supply Co., Inc.	Sloan 3375015	111.93	335.79	EAB	
				Plumbmaster Inc.	Sloan MCR 1001A	124.15	372.45		
				Atlantic Plumbing Supply	Sloan 3375015	115.82	346.86		
				Apple Specialties Inc.	Sloan 3375015	126.25	378.75		

**Contact:** Joseph C. Nastus (VP)  
**Grant Supply Company Inc.**  
901 Joyce Kilmer Avenue  
North Brunswick, NJ 08902  
tel: 1-732-5451018  
fax: 1-732-545-9873  
[gloriao@grantsupply.com](mailto:gloriao@grantsupply.com)

**Contact:** Katie Manley  
**Plumbmaster, Inc.**  
51 LaCruce Avenue  
Concordville, PA 19331  
tel: 1-800-523-5130  
fax: 1-800-338-1867  
[bids@plumbmaster.com](mailto:bids@plumbmaster.com)

**Contact:** Gerard Tilton  
**Apple Specialties Inc.**  
2042 North Country Road  
Wading River, NY 11792  
tel: 1-631-886-2160  
fax: 1-631-886-2161  
[csornv5231@aol.com](mailto:csornv5231@aol.com)

**Contact:** Frank Marchese  
**Atlantic Plumbing Supplies**  
2810 Route 37 East  
Toms River, NJ 08753  
tel: 1-732-929-0400  
fax: 1-732-929-8747  
[fmarchese@atlanticplumbingsupply.net](mailto:fmarchese@atlanticplumbingsupply.net)

Introduced on: March 25, 2014  
Adopted on: March 25, 2014  
Official Resolution#: R20140201

# Passaic County Board of Chosen Freeholders

OFFICE OF THE  
PASSAIC COUNTY FREEHOLDERS

Director Pasquale "Pat" Lepore  
Deputy Director Theodore O. Best, Jr.  
John W. Bartlett  
Ronda Casson Cotroneo  
Terry Duffy  
Bruce James  
Hector C. Lora

401 Grand Street  
Paterson, New Jersey 07505

Tel: 973-881-4402  
Fax: 973-742-3746

Anthony J. De Nova III

Administrator

William J. Pascrell, III, Esq.

County Counsel

Louis E. Imhof, III, RMC

Clerk Of The Board



## Public Meeting (Board Meeting)

Date: Mar 25, 2014 - 5:30 PM

Location: County Administration  
220  
401 Grand Street  
Paterson, NJ 07505

Agenda: RESOLUTION AUTHORIZING AWARD OF CONTRACT TO GRANT SUPPLY CO, INC FOR VARIOUS SLOAN LAVATORY/ SHOWER PARTS FOR PASSAIC COUNTY AS PER BID, ALL AS NOTED IN THE RESOLUTION

THIS RESOLUTION WAS REQUESTED BY:  
SHERIFF'S DEPT

REVIEWED BY:

  
Anthony J. De Nova III  
COUNTY ADMINISTRATOR

APPROVED AS TO FORM AND LEGALITY:

  
William J. Pascrell, III, Esq.  
COUNTY COUNSEL

Administration and Finance  
COMMITTEE NAME

Official Resolution#	R20140202						
Meeting Date	03/25/2014						
Introduced Date	03/25/2014						
Adopted Date	03/25/2014						
Agenda Item	I-3						
CAF #	Various						
Purchase Req. #	TBD						
Result	Adopted						
FREEHOLDER	PRES.	ABS.	MOVE	SEC	AYE	NAY	ABST.
Lepore	✓				✓		
Best Jr	✓		✓		✓		
Bartlett	✓			✓	✓		
Cotroneo	✓				✓		
Duffy	✓				✓		
James	✓				✓		
Lora	✓				✓		

PRES.= present ABS.= absent  
MOVE= moved SEC= seconded  
AYE= yes NAY= no ABST.= abstain

Dated: March 26, 2014

**RESOLUTION AUTHORIZING AWARD OF CONTRACT TO GRANT SUPPLY CO, INC FOR VARIOUS SLOAN LAVATORY/ SHOWER PARTS FOR PASSAIC COUNTY AS PER BID**

**WHEREAS**, there exists a need for various Sloan lavatory and shower parts at the Passaic County buildings; and

**WHEREAS**, the County of Passaic issued a public solicitation to qualified vendors for 2014 Various Sloan Lavatory/Shower Parts for the County of Passaic in accordance with "Fair and Open" procedures as established in the "Pay-to-Play" Law, N.J.S.A. 19:44A-20.4, et seq.; and

**WHEREAS**, the County of Passaic, Department of Purchasing has reviewed and tabulated the proposals/bids as received on February 27, 2014 pursuant to N.J.S.A. 40A: 11-1 et. seq., and has made a recommendation to the Board of Chosen Freeholders for an award of contract to Grant Supply Co, Inc. of N. Brunswick, NJ; and

**WHEREAS**, the Finance, Administration and Personnel Committee has reviewed this matter at its March 12, 2014 meeting and recommends this resolution to the full Board of adoption; and

**WHEREAS**, the contract period will be from April 1, 2014 through March 31, 2015 for an estimated price of \$22,326.14, for line items #1-13, 15, 16, & 18; and

**WHEREAS**, a certificate is attached hereto, indicating that funds are available in various budget accounts for the within contemplated expenditure; and

**NOW THEREFORE BE IT RESOLVED** by the Board of Chosen Freeholders of the County of Passaic that pursuant to the terms and conditions set forth above, it hereby authorizes an award of contract to Grant Supply Co. Inc. of N. Brunswick, NJ for the products referenced above in an amount not to exceed \$22,326.14; and

**BE IT FURTHER RESOLVED** that the Clerk of the Board, the Purchasing Agent and the Director of the Board are hereby authorized to execute all necessary agreements on behalf of the County of Passaic as prepared by the Office of County Counsel for said purpose.



CERTIFICATION OF AVAILABLE FUNDS

THIS IS TO CERTIFY THAT FUNDS ARE AVAILABLE AS FOLLOWS:

AMOUNT: \$22,326.14

APPROPRIATION: Various

PURPOSE: To award a contract to Grant Supply Co., Inc. for various Sloan Lavatory/Shower Parts for Passaic County.

  
Michael Katz, County Treasurer

DATED: February 25, 2014

# Passaic County Board of Chosen Freeholders

OFFICE OF THE  
PASSAIC COUNTY FREEHOLDERS

Director Pasquale "Pat" Lepore  
Deputy Director Theodore O. Best, Jr.  
John W. Bartlett  
Ronda Casson Cotroneo  
Terry Duffy  
Bruce James  
Hector C. Lora

401 Grand Street  
Paterson, New Jersey 07505

Tel: 973-881-4402  
Fax: 973-742-3746

Anthony J. De Nova III

Administrator

William J. Pascrell, III, Esq.

County Counsel

Louis E. Imhof, III, RMC

Clerk Of The Board



## Public Meeting (Board Meeting)

Date: Mar 25, 2014 - 5:30 PM

Location: County Administration  
220  
401 Grand Street  
Paterson, NJ 07505

Agenda:

RESOLUTION AUTHORIZING AWARD OF CONTRACT TO PLUMBMASTER, INC FOR VARIOUS SLOAN LAVATORY/ SHOWER PARTS FOR PASSAIC COUNTY AS PER BID, ALL AS NOTED IN THE RESOLUTION

THIS RESOLUTION WAS REQUESTED BY:

SHERIFF'S DEPT

REVIEWED BY:

Anthony J. De Nova III  
COUNTY ADMINISTRATOR

APPROVED AS TO FORM AND LEGALITY:

William J. Pascrell, III, Esq.  
COUNTY COUNSEL

Administration and Finance

COMMITTEE NAME

Official Resolution#	R20140203						
Meeting Date	03/25/2014						
Introduced Date	03/25/2014						
Adopted Date	03/25/2014						
Agenda Item	I-4						
CAF #	Various						
Purchase Req. #	TBD						
Result	Adopted						
FREEHOLDER	PRES.	ABS.	MOVE	SEC	AYE	NAY	ABST.
Lepore	✓				✓		
Best Jr	✓		✓		✓		
Bartlett	✓			✓	✓		
Cotroneo	✓				✓		
Duffy	✓				✓		
James	✓				✓		
Lora	✓				✓		

PRES.= present ABS.= absent  
MOVE= moved SEC= seconded  
AYE= yes NAY= no ABST.= abstain

Dated: March 26, 2014

**RESOLUTION AUTHORIZING AWARD OF CONTRACT TO PLUMBMASTER, INC FOR VARIOUS SLOAN LAVATORY/ SHOWER PARTS FOR PASSAIC COUNTY AS PER BID**

**WHEREAS**, there exists a need for various Sloan lavatory and shower parts in Passaic County buildings; and

**WHEREAS**, the County of Passaic issued a public solicitation to qualified vendors for 2014 Various Sloan Lavatory/Shower Parts for the County of Passaic in accordance with "Fair and Open" procedures as established in the "Pay-to-Play" Law, N.J.S.A. 19:44A-20.4, et seq.; and

**WHEREAS**, the County of Passaic, Department of Purchasing has reviewed and tabulated the proposals/bids as received on February 27, 2014 pursuant to N.J.S.A. 40A: 11-1 et. seq., and has made a recommendation to the Board of Chosen Freeholders for a contract award to Plumbmaster Inc. of Concordville,; and

**WHEREAS**, the Finance, Administration and Personnel Committee has reviewed this matter at its March 12, 2014 meeting and recommends this resolution to the full Board of adoption; and

**WHEREAS**, the contract period will be from April 1, 2014 through March 31, 2015 for an estimated price of \$322.00, for line item #17; and

**WHEREAS**, a certificate is attached hereto, indicating that funds are available in various budget accounts for the within contemplated expenditure; and

**NOW THEREFORE BE IT RESOLVED** by the Board of Chosen Freeholders of the County of Passaic that pursuant to the terms and conditions set forth above, it hereby authorizes an award of contract to Plumbmaster Inc. of Concordville, PA for the items referenced above in an amount not to exceed \$322.00; and

**BE IT FURTHER RESOLVED** that the Clerk of the Board, the Purchasing Agent and the Director of the Board are hereby authorized to execute all necessary agreements on behalf of the County of Passaic as prepared by the Office of County Counsel for said purpose.

March 25, 2014

CERTIFICATION OF AVAILABLE FUNDS

THIS IS TO CERTIFY THAT FUNDS ARE AVAILABLE AS FOLLOWS:

AMOUNT: \$322.00

APPROPRIATION: Various

PURPOSE: To award a contract to Plumbmaster, Inc. for various Sloan Lavatory/Shower Parts for Passaic County.

  
Michael Katz, County Treasurer

DATED: February 25, 2014

# Passaic County Board of Chosen Freeholders

OFFICE OF THE  
PASSAIC COUNTY FREEHOLDERS

Director Pasquale "Pat" Lepore  
Deputy Director Theodore O. Best, Jr.  
John W. Bartlett  
Ronda Casson Cotroneo  
Terry Duffy  
Bruce James  
Hector C. Lora

401 Grand Street  
Paterson, New Jersey 07505

Tel: 973-881-4402  
Fax: 973-742-3746

Anthony J. De Nova III

Administrator

William J. Pascrell, III, Esq.

County Counsel

Louis E. Imhof, III, RMC

Clerk Of The Board



## Public Meeting (Board Meeting)

Date: Mar 25, 2014 - 5:30 PM

Location: County Administration  
220  
401 Grand Street  
Paterson, NJ 07505

Agenda: RESOLUTION TO PURCHASE VIA STATECONTRACT AND COUNTYCOOPERATIVES, ALL AS NOTED IN THE RESOLUTION

THIS RESOLUTION WAS REQUESTED BY:

PREAKNESS, B&G, PCSD

REVIEWED BY:

Anthony J. De Nova III  
COUNTY ADMINISTRATOR

APPROVED AS TO FORM AND LEGALITY:

William J. Pascrell, III, Esq.  
COUNTY COUNSEL

Administration and Finance

COMMITTEE NAME

<b>Official Resolution#</b>	<b>R20140204</b>						
Meeting Date	03/25/2014						
Introduced Date	03/25/2014						
Adopted Date	03/25/2014						
Agenda Item	I-5						
CAF #	4-01-278-172-001-M02						
Purchase Req. #	TBD						
Result	Adopted						
<b>FREEHOLDER</b>	<b>PRES.</b>	<b>ABS.</b>	<b>MOVE</b>	<b>SEC</b>	<b>AYE</b>	<b>NAY</b>	<b>ABST.</b>
Lepore	✓				✓		
Best Jr	✓		✓		✓		
Bartlett	✓			✓	✓		
Cotroneo	✓				✓		
Duffy	✓				✓		
James	✓				✓		
Lora	✓				✓		

PRES.= present ABS.= absent  
MOVE= moved SEC= seconded  
AYE= yes NAY= no ABST.= abstain

Dated: March 26, 2014

Res-Pg:1.5-2

**RESOLUTION TO PURCHASE VIA STATE CONTRACT AND  
COUNTY COOPERATIVES**

**WHEREAS** various Passaic County Departments and Institutions have requested the purchase of items and services pursuant to State Contract, Cooperative Purchasing Agreements and/or Federal GSA Schedules as indicated in the attached correspondence for the Various Passaic County Departments; and

**WHEREAS** the Board of Chosen Freeholders is desirous of approving said purchase in accordance with the terms of the State Contract, Cooperative Purchasing Agreements and/or Federal GSA Schedules and authorizing the Purchasing Agent to issue the appropriate Purchase Order; and

**WHEREAS** the Passaic County Finance Committee has considered this matter and recommended this resolution to the full Board for adoption; and

**WHEREAS** a certification is attached indicating that funds are available for the above contemplated expenditure;

**NOW THEREFORE BE IT RESOLVED** by the Board of Chosen Freeholders of the County of Passaic that it hereby authorizes the purchase of the goods and/services in accordance with the terms of the applicable State Contract described below:

<b>Vendor</b>	Kleiza Enterprises, Inc
<b>MCCOOP:</b>	#45
<b>Description:</b>	Septic Pumping/Sludge Removal Services
<b>Using Agency:</b>	Parks, PCSD, Operations/Roads, Preakness
<b>Amount:</b>	\$20,000.00
<b>Account:</b>	Various

**Vendor** Seashore Fruit & Co./Frank Gargiulo & Son  
 State Contract: #81102 & #81100  
 Description: Fresh Produce  
 Using Agency: Preakness Meals on Wheels  
 Amount: \$70,000.00  
 Account: 4-01-27-172-001-F04  
 & 4-01-27-172-0001-M02

**Vendor** Rug and Floor Store Inc  
 State Contract: #81748  
 Description: Carpet/Flooring Supply & Install  
 Using Agency: Golf  
 Amount: \$1,900.00  
 Account: Various

**BE IT FURTHER RESOLVED** that the Purchasing Agent and all other necessary officers and employees be and hereby are authorized and directed to take such further actions and sign such documents as are necessary to effectuate the purpose of this resolution, including but not limited to issuance of an appropriate Purchase Order  
 This resolution was requested by:

# Passaic County Board of Chosen Freeholders

OFFICE OF THE  
PASSAIC COUNTY FREEHOLDERS

Director Pasquale "Pat" Lepore  
Deputy Director Theodore O. Best, Jr.  
John W. Bartlett  
Ronda Casson Cotroneo  
Terry Duffy  
Bruce James  
Hector C. Lora

401 Grand Street  
Paterson, New Jersey 07505

Tel: 973-881-4402  
Fax: 973-742-3746

Anthony J. De Nova III

Administrator

William J. Pascrell, III, Esq.

County Counsel

Louis E. Imhof, III, RMC

Clerk Of The Board



## Public Meeting (Board Meeting)

Date: Mar 25, 2014 - 5:30 PM

Location: County Administration  
220  
401 Grand Street  
Paterson, NJ 07505

Agenda:

RESOLUTION AUTHORIZING AWARD OF CONTRACT TO AIR SYSTEMS MAINTENANCE INC FOR THE PREVENTATIVE MAINTENANCE FOR AIR COOLED CHILLERS AND SERVICE/REPAIR OF AIR CONDITIONING HEATING AND REFRIGERATION UNITS IN PASSAIC COUNTY BUILDINGS AS PER BID, ALL AS NOTED IN THE RESOLUTION

THIS RESOLUTION WAS REQUESTED BY:

BUILDINGS & GROUNDS

REVIEWED BY:

Anthony J. De Nova III  
COUNTY ADMINISTRATOR

APPROVED AS TO FORM AND LEGALITY:

William J. Pascrell, III, Esq.  
COUNTY COUNSEL

Administration and Finance

COMMITTEE NAME

<b>Official Resolution#</b>	<b>R20140205</b>						
Meeting Date	03/25/2014						
Introduced Date	03/25/2014						
Adopted Date	03/25/2014						
Agenda Item	I-6						
CAF #	4-01-20-112-001-219						
Purchase Req. #	TBD						
Result	Adopted						
<b>FREEHOLDER</b>	<b>PRES.</b>	<b>ABS.</b>	<b>MOVE</b>	<b>SEC</b>	<b>AYE</b>	<b>NAY</b>	<b>ABST.</b>
Lepore	✓				✓		
Best Jr	✓		✓		✓		
Bartlett	✓			✓	✓		
Cotroneo	✓				✓		
Duffy	✓				✓		
James	✓				✓		
Lora	✓				✓		

PRES.= present ABS.= absent  
MOVE= moved SEC= seconded  
AYE= yes NAY= no ABST.= abstain

Dated: March 26, 2014



**RESOLUTION AUTHORIZING AWARD OF CONTRACT TO AIR SYSTEMS MAINTENANCE INC. FOR THE PREVENTATIVE MAINTENANCE FOR AIR COOLED CHILLERS AND SERVICE/REPAIR OF AIR CONDITIONING HEATING AND REFRIGERATION UNITS IN PASSAIC COUNTY BUILDINGS AS PER BID**

**WHEREAS** it is necessary to keep the air conditioning and heating units in Passaic County buildings maintained and serviced and to perform repairs when needed; and

**WHEREAS** the County issued a public solicitation to qualified vendors for Preventative Maintenance Service for Air Cooled Chillers and Service/Repair of Air conditioning, Heating and Refrigeration Units Maintenance, in accordance with “Fair and Open” procedures as established in the “Pay to Play” Law, N.J.S.A. 19:44A-20.4, et seq.; and

**WHEREAS** the County of Passaic, Department of Purchasing has reviewed and tabulated proposals/bids as received pursuant to N.J.S.A. 40A:11-1 et seq., and has made a recommendation to the Board of Chosen Freeholders of the County of Passaic for an award of contract to Air Systems Maintenance, Inc. of Kenilworth, NJ; and

**WHEREAS** the Finance, Administration and Personnel Committee has reviewed this matter and recommends this resolution to the full Board for adoption; and

**WHEREAS** the contract period will be from February 1, 2014 through January 31, 2016 for an estimated 1<sup>st</sup> year price of \$16,060.00 with \$6,155.00 option 1 and 2<sup>nd</sup> year price of \$16,856.00 and \$6,155.00 option 1; and

**WHEREAS** a certification is attached hereto that are available in budget account 4-01-20-112-001-219 for the within contemplated expenditure;

**NOW THEREFORE BE IT RESOLVED** by the Board of Chosen Freeholders of Passaic County that pursuant to the terms and conditions set forth above, it hereby authorizes an award of contract to Air Systems Maintenance, Inc., of Kenilworth, NJ for the services referenced above in an amount not to exceed \$22,215.00 for year 1 and \$23,011.00 for year 2; and

**BE IT FURTHER RESOLVED** that the Clerk of the Board, Purchasing Agent and Director of the Board are authorized to execute all necessary agreements on behalf of Passaic County as prepared by the Office of the County Counsel for said purpose.

CERTIFICATION OF AVAILABLE FUNDS

THIS IS TO CERTIFY THAT FUNDS ARE AVAILABLE AS FOLLOWS:

AMOUNT: \$45,226.00

APPROPRIATION: \$20,363.75 - 4-01-20-112-001-219  
\$24,862.25 - Contingent upon necessary funds  
being appropriated in future budgets.

PURPOSE: To award a contract to Air Systems Maintenance, Inc.  
for the preventive maintenance for air cooled chillers  
and service/repair of air conditioning, heating and  
refrigeration units in Passaic County Buildings for the  
period February 1, 2014 through January 31, 2016.

  
Michael Katz, County Treasurer

DATED: February 25, 2014



County of Passaic  
PROCUREMENT CENTER  
495 RIVER STREET  
SECOND FLOOR  
PATERSON, NEW JERSEY 07524

---

Michael Marinello, QPA, CCPO  
Purchasing Agent

Tel: (973) 247-3300  
Fax: (973) 742-8295

March 19, 2014

Board of Chosen Freeholders  
Administration Building

Re: Preventative Maintenance Service for Air Cooled Chillers and Service/Repair of Air Conditioning, Heating and Refrigeration Units

Contract Period: February 1, 2014 through December 31, 2015

ATTN: Lou Imhof, Clerk to the Board

Dear Mr. Imhof:

Bids were received at 10:30 am, on February 25, 2014 in the Passaic County Procurement Center. The bids were received and read aloud as follows:

Air Systems Maint. Yr 1-\$16,060.00 Opt. 1\$6,155.00 / Yr 2-\$16,856.00 Opt.1 \$6155.00

GRM Facilities Mgt. Yr 1-\$123,760.00 Opt. 1\$27,285.00/Yr 2 \$127,474.00 Opt. 1 \$28,098.00

This was solicited in a Fair and Open Process. Bids were received and evaluated by Jack Nigro Superintendent of Buildings and Grounds, and it is his recommendation that a contract be awarded to Air Systems Maintenance of Kenilworth, NJ, as per the attached memo. This bid was evaluated on the basis of the vendor bidding the lowest responsible price.

Sincerely,

  
Michael Marinello, QPA, CCPO



# County of Passaic

Administration Building

317 Pennsylvania Avenue • Paterson, New Jersey 07503

Jack Nigro  
County Superintendent of  
Buildings and Grounds

TEL: (973) 881-4425  
CELLPHONE: (973) 592-2168  
PAGER: (973) 308-0157  
FAX: (973) 754-1988  
E-MAIL: jackn@passaiccountynj.org

DATE: March 14, 2014

TO: Michael Marinello, Director of Purchasing

FROM: Jack Nigro, Superintendent  
Buildings & Grounds

SUBJECT: Recommendation for Award, 2014-2015 Preventative Maintenance  
Service for Air Cooled Chillers & Service Repair

I have reviewed the proposals submitted for the above Preventative Maintenance Service Bids received on February 25, 2014. The Public Works Committee reviewed said bids at their meeting held on March 10, 2014, and approved an award of contract to the low bidder, Air Systems Maintenance, in the amount of:

- \$16,060 the first year/Option 1, \$6,155
- \$16,856 the second year/Option 1, \$6,155

pending certification of funds. Note: various account numbers will be used

DATE: March 14, 2014  
Please prepare the necessary resolution to be placed on the agenda of the next scheduled Board of Chosen Freeholders meeting on March 25, 2014.

FROM: Jack Nigro, Superintendent  
Buildings & Grounds

SUBJECT: Recommendation for Award, 2014-2015 Preventative Maintenance  
Service for Air Cooled Chillers & Service Repair

I have reviewed the proposals submitted for the above Preventative Maintenance Service Bids received on February 25, 2014. The Public Works Committee reviewed said bids at their meeting held on March 10, 2014, and approved an award of contract to the low bidder, Air Systems Maintenance, in the amount of:

**FAXED**

Introduced on: March 25, 2014  
Adopted on: March 25, 2014  
Official Resolution#: R20140205

pending certification of funds

**COUNTY OF PASSAIC  
 BID TALLY SHEET**

Res-Pg:1.6-7

Michael Marinello, R.P.P.S.  
 Purchasing Agent  
 Jose Santiago, Esq.  
 Assistant County Counsel

William J. Pascrell, III, Esq.  
 County Counsel  
 Matthew Malfa  
 Deputy County Counsel

Taken by Attorney Jose Santiago  
 Taken by R.P.P.S. Nick Naumov  
 Typed by Theresa Scuttaro

**PURCHASING DEPARTMENT**

**Bids received at 10:30 a.m. on FEBRUARY 25, 2014 the Passaic County Procurement Center, 495 River Street Second Floor, Paterson, NJ 07524**

**SB-14-004 (HVAC) PREVENTATIVE MAINTENANCE SERVICE FOR AIR COOLED CHILLERS AND SERVICE REPAIR**

Vendor	Disc. Stm. (Exh. I)	Non-Coll. Aff. (Exh. II)	B.B. C.Ck. Cs. Check (Exh. III)	Con. Of Surety (Exh. IV)	Last Page (Exh. V)	Business Reg. Cert.	Avail to Co-Op	Disc. I/A Iran	Bid Total
T.M. BRENNAN CONTRACTORS, INCL C/O JESSICA HOLDEN 3505 ROUTE 94 HAMBURG, NJ 07419 973-209-1018									
GRM FACILITIES MANAGEMENT C/O ED MAKEL 188 FRIES MILL RD. SUITE F-2 TURNERVILLE, NJ 08012	X	X	N/A	X	X	X	X	X	PART (A) LUMP SUM  1 <sup>ST</sup> YR = \$123,760.00 2 <sup>ND</sup> YR = \$127,474.00  COND 1 <sup>ST</sup> YR. = \$27,285.00 COND 2 <sup>ND</sup> YR = \$28,098.00  PART "B" (SEE PROPOSAL)
PRIME VENDOR INC. C/O KIMBERLT DOUMIT 4622 CEDAR AVE WILMINGTON, NC 28403 800-746-8307									

Introduced on: March 25, 2014  
 Adopted on: March 25, 2014  
 Official Resolution#: R20140205

**COUNTY OF PASSAIC  
 BID TALLY SHEET**

Michael Marinello, R.P.P.S.  
 Purchasing Agent  
 Jose Santiago, Esq.  
 Assistant County Counsel  
*Taken by Attorney*  
*Taken by R.P.P.S.*  
 Typed by

William J. Pascroll, III, Esq.  
 County Counsel  
 Matthew Malfa  
 Deputy County Counsel

**Straight Bids**

**PURCHASING DEPARTMENT**

**Bids received at 10:30 a.m. on FEBRUARY 25, 2014 the Passaic County Procurement Center, 495 River Street Second Floor, Paterson, NJ 07524**

**SB-14-004 (HVAC) PREVENTATIVE MAINTENANCE SERVICE FOR AIR COOLED CHILLERS AND SERVICE REPAIR**

Vendor	Disc. Stm. (Exh. I)	Non-Coll. Aff. (Exh. II)	B.B. C.Ck. Cs. Check (Exh. III)	Con. Of Surety (Exh. IV)	Last Page (Exh. V)	Business Reg. Cert.	Avail to Co-Op	Disc. I/A Iran	Bid Total
MARKS HVAC P.O. BOX 919 SADDLE BROOK, NJ 07663-0919 201-342-9450									
T.M. BRENNAN CONTRACTORS, INCL C/O JESSICA HOLDEN 3505 ROUTE 94 HAMBURG, NJ 07419 973-209-1018	X	X	N/A	X	X	X	X	<b>SUBJECT TO REVIEW NOT SIGNED</b>	PART "A" LUMP SUM 1 <sup>ST</sup> \$16,060.00 2 <sup>ND</sup> \$16,856.00  PART "B" (SEE PROPOSAL) COND. 1 <sup>ST</sup> YR. \$6,155.00 COND. 2 <sup>ND</sup> YR. \$6,155.00
PATRIOT ENERGY, LLC C/O MICK REILLY 321 FAIRFIELD RD FAIRFIELD, NJ 07004 973-227-6113									

**COUNTY OF PASSAIC**  
**BID TALLY SHEET**  
Straight Bids

Michael Marinello, R.P.P.S.  
Purchasing Agent  
Jose Santiago, Esq.  
Assistant County Counsel  
*Taken by Attorney*  
*Taken by R.P.P.S.*  
Typed by

William J. Pascrell, III, Esq.  
County Counsel  
Matthew Malfa  
Deputy County Counsel

**PURCHASING DEPARTMENT**

**Bids received at 10:30 a.m. on FEBRUARY 25, 2014 the Passaic County Procurement Center, 495 River Street Second Floor, Paterson, NJ 07524**

**SB-14-004 (HVAC) PREVENTATIVE MAINTENANCE SERVICE FOR AIR COOLED CHILLERS AND SERVICE REPAIR**

Vendor	Disc. Stm. (Exh. I)	Non-Coll. Aff. (Exh. II)	B.B. C.Cl. Cs. Check (Exh. III)	Con. Of Surety (Exh. IV)	Last Page (Exh. V)	Business Reg. Cert.	Avail to Co-Op	Disc. I/A Iran	Bid Total
AIRGAS REFRIGERANTS, INC. C/O JEREMY GRUMBLER 38-18 33 <sup>RD</sup> ST. LONG ISLAND CITY, NY 11101 718-392-8006									
CENTRAL ABSORPTION INC. C/O ALVIN RAMOS 11-15 31 <sup>ST</sup> DR, LONG ISLAND CITY, NY 11106 718-626-4691									



# Passaic County Board of Chosen Freeholders

OFFICE OF THE  
PASSAIC COUNTY FREEHOLDERS

Director Pasquale "Pat" Lepore  
Deputy Director Theodore O. Best, Jr.  
John W. Bartlett  
Ronda Casson Cotroneo  
Terry Duffy  
Bruce James  
Hector C. Lora

401 Grand Street  
Paterson, New Jersey 07505

Tel: 973-881-4402  
Fax: 973-742-3746

Anthony J. De Nova III

Administrator

William J. Pascrell, III, Esq.

County Counsel

Louis E. Imhof, III, RMC

Clerk Of The Board



## Public Meeting (Board Meeting)

Date: Mar 25, 2014 - 5:30 PM

Location: County Administration  
220  
401 Grand Street  
Paterson, NJ 07505

Agenda: RESOLUTION APPOINTING RICHARD P. CAHILL AS CHIEF FINANCIAL OFFICER FOR THE COUNTY OF PASSAIC FOR THE TERM PROVIDED BY LAW, I.E, EFFECTIVE IMMEDIATELY AND TERMINATING ON DECEMBER 31, 2016, ALL AS NOTED IN THE RESOLUTION

THIS RESOLUTION WAS REQUESTED BY:

REVIEWED BY:

Anthony J. De Nova III  
COUNTY ADMINISTRATOR

APPROVED AS TO FORM AND LEGALITY:

William J. Pascrell, III, Esq.  
COUNTY COUNSEL

Administration and Finance  
COMMITTEE NAME

Official Resolution#		R20140206						
Meeting Date		03/25/2014						
Introduced Date		03/25/2014						
Adopted Date		03/25/2014						
Agenda Item		I-7						
CAF #								
Purchase Req. #								
Result		Adopted						
FREEHOLDER	PRES.	ABS.	MOVE	SEC	AYE	NAY	ABST.	
Lepore	✓				✓			
Best Jr	✓		✓		✓			
Bartlett	✓			✓	✓			
Cotroneo	✓				✓			
Duffy	✓				✓			
James	✓				✓			
Lora	✓				✓			

PRES.= present ABS.= absent  
MOVE= moved SEC= seconded  
AYE= yes NAY= no ABST.= abstain

Dated: March 26, 2014

**RESOLUTION APPOINTING RICHARD P. CAHILL AS CHIEF FINANCIAL OFFICER FOR THE COUNTY OF PASSAIC FOR THE TERM PROVIDED BY LAW, I.E, EFFECTIVE IMMEDIATELY AND TERMINATING ON DECEMBER 31, 2016**

**WHEREAS** the Board of Chosen Freeholders of the County of Passaic (the “Board”) is authorized, pursuant to N.J.S.A 40A:9-28.4a., to appoint a Chief Financial Officer for the County of Passaic (the “County”) for a term of three (3) years, which term shall run from January 1<sup>st</sup> of the year in which the appointment is made; and

**WHEREAS** pursuant to N.J.S.A. 40A:9-28.4c., all persons so appointed after July 1, 1996 are required to hold a county finance officer certificate issued in accordance with applicable law; and

**WHEREAS** in the event of a vacancy in the position of a certified county finance officer, the governing body is authorized pursuant to N.J.S.A. 40A:9-28.4 (d) to appoint a person who does not hold a county finance officer certificate to serve as Temporary Chief Financial Officer for a period of one (1) year, commencing on the date of the vacancy; and

**WHEREAS** the Board adopted a resolution (R-13-136, 02/26/13) authorizing a temporary appointment due to the resignation of Louis Garbaccio, which took effect on March 8, 2013; and

**WHEREAS** the Board subsequently hired Richard P. Cahill as director of finance, and adopted a resolution (R-2013-472, 07/16/2013) designating Mr. Cahill as Temporary Chief Financial

Officer for a period of one (1) year, retroactive to the date of the vacancy, in accordance with N.J.S.A. 9-28.4 (a).; and

**WHEREAS** the Board has recently been advised that Mr. Cahill has successfully completed the prescribed courses and has been issued a county finance officer certificate; and

**WHEREAS** since Mr. Cahill now possesses the education and experience required for appointment as County Chief Financial Officer, the Board is desirous of appointing him to said position for the term provided by N.J.S.A. 40A:9-28.4 (a), i.e. commencing immediately and terminating December 31, 2016; and

**WHEREAS** the Administration and Finance Committee considered this matter at its meeting of March 12, 2014 and recommended this resolution to the full Board for adoption;

**NOW THEREFORE BE IT RESOLVED** by the Board of Chosen Freeholders of the County of Passaic that Richard P. Cahill be and hereby is appointed as Chief Financial Officer for the County of Passaic, for a term commencing immediately and terminating on December 31, 2016, in accordance with N.J.S.A. 40A:9-28.4.

Dated: March 25, 2014

# Passaic County Board of Chosen Freeholders

OFFICE OF THE  
PASSAIC COUNTY FREEHOLDERS

Director Pasquale "Pat" Lepore  
Deputy Director Theodore O. Best, Jr.  
John W. Bartlett  
Ronda Casson Cotroneo  
Terry Duffy  
Bruce James  
Hector C. Lora

401 Grand Street  
Paterson, New Jersey 07505

Tel: 973-881-4402  
Fax: 973-742-3746

Anthony J. De Nova III

Administrator

William J. Pascrell, III, Esq.

County Counsel

Louis E. Imhof, III, RMC

Clerk Of The Board



## Public Meeting (Board Meeting)

Date: Mar 25, 2014 - 5:30 PM

Location: County Administration  
220  
401 Grand Street  
Paterson, NJ 07505

Agenda: RESOLUTION AUTHORIZING AWARD OF CONTRACT TO SHINDLER ELEVATOR CORP FOR THE SERVICE AND MAINTENANCE OF THIRTY-THREE ELEVATORS IN VARIOUS PASSAIC COUNTY BUILDINGS AS PER BID, ALL AS NOTED IN THE RESOLUTION

THIS RESOLUTION WAS REQUESTED BY:  
BUILDINGS & GROUNDS

REVIEWED BY:

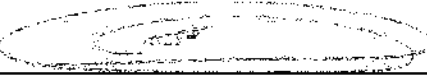
  
Anthony J. De Nova III  
COUNTY ADMINISTRATOR

APPROVED AS TO FORM AND LEGALITY:

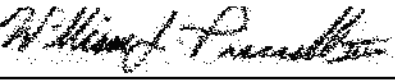
  
William J. Pascrell, III, Esq.  
COUNTY COUNSEL

Administration and Finance  
COMMITTEE NAME

<b>Official Resolution#</b>	<b>R20140207</b>						
Meeting Date	03/25/2014						
Introduced Date	03/25/2014						
Adopted Date	03/25/2014						
Agenda Item	I-8						
CAF #	4-01-20-112-001-219						
Purchase Req. #	TBD						
Result	Adopted						
<b>FREEHOLDER</b>	<b>PRES.</b>	<b>ABS.</b>	<b>MOVE</b>	<b>SEC</b>	<b>AYE</b>	<b>NAY</b>	<b>ABST.</b>
Lepore	✓				✓		
Best Jr	✓		✓		✓		
Bartlett	✓			✓	✓		
Cotroneo	✓				✓		
Duffy	✓				✓		
James	✓				✓		
Lora	✓				✓		

PRES.= present ABS.= absent  
MOVE= moved SEC= seconded  
AYE= yes NAY= no ABST.= abstain

Dated: March 26, 2014

**RESOLUTION AUTHORIZING AWARD OF CONTRACT TO SHINDLER ELEVATOR CORP FOR THE SERVICE AND MAINTENANCE OF THIRTY-THREE ELEVATORS IN VARIOUS PASSAIC COUNTY BUILDINGS AS PER BID**

**WHEREAS**, there exists a need to keep the elevators located in Passaic County buildings in good working order and up-to-date with their inspections; and

**WHEREAS**, the County of Passaic issued a public solicitation to qualified vendors for Maintenance and Service of (33) Thirty-Three Elevators in Various Passaic County Buildings in accordance with "Fair and Open" procedures as established in the "Pay-to-Play" Law, N.J.S.A. 19:44A-20.4, et seq.; and

**WHEREAS**, the County of Passaic, Department of Purchasing has reviewed and tabulated the proposals/bids as received on January 23, 2014 pursuant to N.J.S.A. 40A: 11-1 et. seq., and has made a recommendation to the Board of Chosen Freeholders for a contract award to Schindler Elevator Corp of Morristown, NJ; and

**WHEREAS**, the Finance, Administration and Personnel Committee has reviewed this matter at its March 12, 2014 meeting and recommends this resolution to the full Board of adoption; and

**WHEREAS**, the contract period will be from February 1, 2014 through January 31, 2016 with one-year option to renew as per the County of Passaic for an estimated 1<sup>st</sup> year price of \$51,333.00, 2<sup>nd</sup> year \$52,873.00 and option year \$54,459.00; and

**WHEREAS**, a certificate is attached hereto, indicating that funds are available in budget account 4-01-20-112-001-213 for the within contemplated expenditure; and

**NOW THEREFORE BE IT RESOLVED** by the Board of Chosen Freeholders of the County of Passaic that pursuant to the terms and conditions set forth above, it hereby authorizes an award of contract to Schindler Elevator of Morristown, NJ for the services referenced above in an amount not to exceed \$104,206.00; and

**BE IT FURTHER RESOLVED** that the Clerk of the Board, the Purchasing Agent and the Director of the Board are hereby authorized to execute all necessary agreements on behalf of the County of Passaic as prepared by the Office of County Counsel

CERTIFICATION OF AVAILABLE FUNDS

THIS IS TO CERTIFY THAT FUNDS ARE AVAILABLE AS FOLLOWS:

AMOUNT: \$104,206.00

APPROPRIATION: \$47,055.25 - 4-01-20-112-001-219  
\$57,150.75 - Contingent upon necessary funds  
being appropriated in future budgets.

PURPOSE: To award a contract to Schindler Elevator Corporation  
for the service and maintenance of thirty-three  
elevators in various Passaic County buildings for the  
period February 1, 2014 through January 31, 2016.

  
Michael Katz, County Treasurer

DATED: February 25, 2014



# County of Passaic

Procurement Center  
495 River Street, Paterson, NJ 07524

Michael Marinello, QPA, CCPO  
*Purchasing Agent*

[mmarinello@passaiccountynj.org](mailto:mmarinello@passaiccountynj.org)  
[www.passaiccountynj.org](http://www.passaiccountynj.org)  
Tel: (973) 247-3301  
Fax: (973) 279-6234

March 18<sup>th</sup>, 2014

Board of Chosen Freeholders  
Administration Building

Re: Maintenance & Service of Thirty-three Elevators in Various Passaic County Buildings

Contract Period: February 1, 2014 through January 31, 2016 with one-year option to renew

ATTN: Lou Imhof, Clerk to the Board

Dear Mr. Imhof:

Bids were received at 10:30 am, on January 23, 2014 in the Passaic County Procurement Center. The bids were received and read aloud as follows:

Schindler Elevator Corp.	Bid \$104,206.00
Richmond Elevator Co	Bid \$242,064.00
Hudson Elevator Group	Bid \$293,760.00

This was solicited in a Fair and Open Process. Bids were received and evaluated by Jack Nigro Superintendent of Buildings and Grounds, and it is his recommendation that a contract be awarded to Schindler Elevator Corp, as per the attached memo. This bid was evaluated on the basis of the vendor bidding the lowest responsible price.

Sincerely,

Michael Marinello, QPA, CCPO

Purchasing Agent



# County of Passaic

Administration Building

317 Pennsylvania Avenue • Paterson, New Jersey 07503

Jack Nigro  
County Superintendent of  
Buildings and Grounds

TEL: (973) 881-4425  
CELLPHONE: (973) 592-2168  
PAGER: (973) 308-0157  
FAX: (973) 754-1988  
E-MAIL: jackn@passaiccountynj.org

March 20, 2014

Mr. Michael Marinello, R.P.P.S.  
Purchasing Director, County of Passaic  
Passaic County Procurement Center  
495 River Street  
Paterson, New Jersey 07524

Re: SB 14-002, Maintenance and Service Passaic County Building Elevators

Dear Mr. Marinello:

I have reviewed the bids received by your Department on January 23, 2014 and recommend that the contract be awarded to the lowest responsible bidder, Schindler c/o Bryan O'Rourke, 20 Whippany Road, Suite 122, Morristown, New Jersey 07960. First year contract amount will be \$51,333.00 and the second year contract amount will be \$52,873.00 for a total of \$104,206.00. The bid includes an option for a one-year extension at the rate of \$54,459.00 for the year.

If you should have any questions or I can be of additional assistance, please feel free to contact me.

Very truly yours,

A handwritten signature in black ink, appearing to read "Jack Nigro", with a long horizontal line extending to the right.

Jack Nigro  
Superintendent Buildings & Grounds

JN/esc



**COUNTY OF PASSAIC**

**BID TALLY SHEET**

**Straight Bids**

Res-Pg:1.8-6

Michael Marinello, R.P.P.S.  
 Purchasing Agent  
 Jose Santiago, Esq.  
 Assistant County Counsel

William J. Pascrell, III, Esq.  
 County Counsel  
 Matthew Malfa  
 Deputy County Counsel

*Taken by Attorney*

*Taken by R.P.P.S.*

*Typed by*

**PURCHASING DEPARTMENT**

**Bids received at 10:30 a.m. on JANUARY 23, 2014** the Passaic County Procurement Center, 495 River Street Second Floor, Paterson, NJ 07524

**SB-14-002 MAINTENANCE AND SERVICE 33 ELEVATORS FOR PASSAIC COUNTY BUILDINGS**

Vendor	Disc. Stm. (Exh. I)	Non-Coll. Aff. (Exh. II)	B.B. C.Cl. Cs. Check (Exh. III)	Con. Of Surety (Exh. IV)	Last Page (Exh. V)	Business Reg. Cert.	Avail to Co-Op	Disc. I/A Iran	Bid Total
SCHINDLER C/O BRYAN O'ROURKE 20 WHIPPANY RD. SUITE 122 MORRISTOWN, NJ 07960-4524 973-397-3710	Subj to review	X			X	X	YES	X	1 <sup>ST</sup> YR = \$51,333.00 2 <sup>ND</sup> YR = \$52,873.00 OPT YR - \$54,459.00 TWO YR TOTAL \$104,206.00
GT MARKETING LTD C/O PAUL NYFENGER 51 RAILROAD AVE CLOSTER, NJ 076224 888-884-7875									
RICHMOND ELEVATOR CO. INC C/O JIM DUFFY 17 RECTOR STREET STATEN ISLAND NY 10310 FAX # 718 720 3301	X	X			X	X	YES	X	1 <sup>ST</sup> YR \$118,368.00 2 <sup>ND</sup> YR \$123,696.00 OPT = \$127,756.00 TWO YR. TOTAL \$242,064.00

Introduced on: March 25, 2014  
 Adopted on: March 25, 2014  
 Official Resolution#: R20140207

**COUNTY OF PASSAIC**

**BID TALLY SHEET**

**Straight Bids**

Michael Marinello, R.P.P.S.

Purchasing Agent

Jose Santiago, Esq.

Assistant County Counsel

Taken by Attorney **J. Santiago**

Taken by R.P.P.S. **Nick Naumov**

Typed by **Theresa Scuttaro**

William J. Pascrell, III, Esq.

County Counsel

Matthew Malfa

Deputy County Counsel

**PURCHASING DEPARTMENT**

**Bids received at 10:30 a.m. on JANUARY 23, 2014 the Passaic County Procurement Center, 495 River Street Second Floor, Paterson, NJ 07524**

**SB-14-002 MAINTENANCE AND SERVICE 33 ELEVATORS FOR PASSAIC COUNTY BUILDINGS**

Vendor	Disc. Strm. (Exh. I)	Non-Coll. Aff. (Exh. II)	B.B. C.Cl. Cs. Check (Exh. III)	Con. Of Surety (Exh. IV)	Last Page (Exh. V)	Business Reg. Cert.	Avail to Co-Op	Disc. I/A Iran	BID TALLY
HUDSON ELEVATOR GROUP C/O TODD LIBERTO 1200 ROUTE 22 EAST SUITE 200 BRIDGEWATER, NJ 08807 877-876-7878	X	X			X	X	YES	YES	1 <sup>ST</sup> YR. \$144,000.00 2 <sup>ND</sup> YR \$149,760.00 OPT YR. = \$155,748.00  TWO YR. TOTAL \$293,760.00
PREFERRED ELEVATOR INC. 555 SECAUCUS RD. SECAUCUS, NJ 07094 201-348-5581									
SLADE ELEVATOR C/O SAVINO ALVIGGI 1101 BRISTOL RD. MOUNTAINSIDE, NJ 07092 212-724-7117									

Introduced on: March 25, 2014  
Adopted on: March 25, 2014  
Official Resolution#: R20140207

# Passaic County Board of Chosen Freeholders

OFFICE OF THE  
PASSAIC COUNTY FREEHOLDERS

Director Pasquale "Pat" Lepore  
Deputy Director Theodore O. Best, Jr.  
John W. Bartlett  
Ronda Casson Cotroneo  
Terry Duffy  
Bruce James  
Hector C. Lora

401 Grand Street  
Paterson, New Jersey 07505

Tel: 973-881-4402  
Fax: 973-742-3746

Anthony J. De Nova III

Administrator

William J. Pascrell, III, Esq.

County Counsel

Louis E. Imhof, III, RMC

Clerk Of The Board



## Public Meeting (Board Meeting)

Date: Mar 25, 2014 - 5:30 PM

Location: County Administration  
220  
401 Grand Street  
Paterson, NJ 07505

Agenda: RESOLUTION AUTHORIZING A CONTRACT BETWEEN THE COUNTY PASSAIC AND COST CONTAINMENT EXPRESS OF MEMPHIS, TENNESSEE FOR OUT-OF-NETWORK COST CONTAINMENT SERVICES RELATIVE TO THE COUNTY'S SELF-FUNDED HEALTH BENEFITS PLAN, ALL AS NOTED IN THE RESOLUTION

THIS RESOLUTION WAS REQUESTED BY:

REVIEWED BY:

  
Anthony J. De Nova III  
COUNTY ADMINISTRATOR

APPROVED AS TO FORM AND LEGALITY:

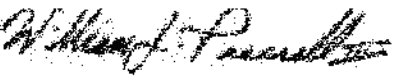
  
William J. Pascrell, III, Esq.  
COUNTY COUNSEL

Administration and Finance

COMMITTEE NAME

Official Resolution#	R20140208						
Meeting Date	03/25/2014						
Introduced Date	03/25/2014						
Adopted Date	03/25/2014						
Agenda Item	I-9						
CAF #							
Purchase Req. #							
Result	Adopted						
FREEHOLDER	PRES.	ABS.	MOVE	SEC	AYE	NAY	ABST.
Lepore	✓				✓		
Best Jr	✓		✓		✓		
Bartlett	✓			✓	✓		
Cotroneo	✓				✓		
Duffy	✓				✓		
James	✓				✓		
Lora	✓				✓		

PRES.= present ABS.= absent  
MOVE= moved SEC= seconded  
AYE= yes NAY= no ABST.= abstain

Dated: March 26, 2014

**RESOLUTION AUTHORIZING A CONTRACT BETWEEN THE COUNTY PASSAIC AND COST CONTAINMENT EXPRESS OF MEMPHIS, TENNESSEE FOR OUT-OF-NETWORK COST CONTAINMENT SERVICES RELATIVE TO THE COUNTY'S SELF-FUNDED HEALTH BENEFITS PLAN**

**WHEREAS** the Board of Chosen Freeholders of the County of Passaic (the "Board") is committed to exploring appropriate means of reducing the expenses associated with employee health benefits; and

**WHEREAS** the Board is concerned with the rising costs being incurred by the County's self-funded health benefits plan due to the utilization of out-of-network providers by covered individuals; and

**WHEREAS** the Board is desirous of developing and implementing a program to control said out-of-network costs, and believes that the services of a specialized consultant is needed to achieve these goals, with the fees for such services to be determined by a percentage of the savings realized; and

**WHEREAS** the County issued a public solicitation for qualified companies to provide the services described above, in accordance with the "Fair and Open" procedures as established in the "Pay-to-Play" Law, N.J.S.A. 19:44A-20.4, et seq.; and

**WHEREAS** the County received responses to its Request for Quotations for the services noted above on February 26, 2014; and

**WHEREAS** the proposals submitted have been reviewed by the County's insurance consultants, who have recommended to the Freeholder Board that the proposal submitted by Cost Containment Express of Memphis, Tennessee (the "Consultant") be accepted and a contract awarded accordingly for a contract term commencing

June 1, 2014 and terminating May 31, 2015, with an option to renew at the County's discretion for an additional term of one (1) year; and

**WHEREAS** the fee for the Consultant's services shall be 13.5% of savings, which the consultant shall withhold from the savings it collects and forward the balance to the County; and

**WHEREAS** the Consultant agrees to absorb any reasonable fees imposed as a result of the Consultant's efforts by Horizon Blue Cross and Blue Shield of New Jersey, which serves as the Third-Party Administrator for the County's self-funded health benefits plan;

**WHEREAS** based on said review and recommendation, the Board is desirous of awarding said contract as outlined above; and

**WHEREAS** the Insurance Committee considered this matter at its meeting of March 13, 2014 and recommended this resolution to the full Board for adoption;

**WHEREAS** no certification of funds is required, as any savings realized will constitute revenue to the County;

**NOW THEREFORE BE IT RESOLVED** by the Board of Chosen Freeholders of the County of Passaic that a contract be and hereby is awarded to Cost Containment Express of Memphis, Tennessee to perform the necessary services on the terms summarized above and more fully contained in the submitted proposal; and

**BE IT FURTHER RESOLVED** that the Director and Clerk to the said Board are hereby authorized to execute the necessary documents on behalf of the County of Passaic; and

**BE IT FURTHER RESOLVED** that this Contract is awarded exempt from public under the Local Public Contracts Law, specifically N.J.S.A. 40A:11-5(1)(m), which applies to insurance and insurance-related services consulting services, and is accordingly authorized for procurement under the Competitive Contracting provision established by N.J.S.A. 40A:11-4.1, et seq; and

**BE IT FURTHER RESOLVED** that although exempt from formal public bidding, procurement via Competitive Contracting satisfies the “Fair and Open” procedures as established in the “Pay-to-Play” Law, N.J.S.A. 19:44A-20.4, et seq; and

**BE IT FURTHER RESOLVED** that a Notice of this action be published in the NORTH JERSEY HERALD & NEWS.

Dated: March 25, 2014

# Passaic County Board of Chosen Freeholders

OFFICE OF THE  
PASSAIC COUNTY FREEHOLDERS

Director Pasquale "Pat" Lepore  
Deputy Director Theodore O. Best, Jr.  
John W. Bartlett  
Ronda Casson Cotroneo  
Terry Duffy  
Bruce James  
Hector C. Lora

401 Grand Street  
Paterson, New Jersey 07505  
Tel: 973-881-4402  
Fax: 973-742-3746

Anthony J. De Nova III  
*Administrator*  
William J. Pascrell, III, Esq.  
*County Counsel*  
Louis E. Imhof, III, RMC  
*Clerk Of The Board*



## Public Meeting (Board Meeting)

Date: Mar 25, 2014 - 5:30 PM

Location: County Administration  
220  
401 Grand Street  
Paterson, NJ 07505

Agenda: RESOLUTION AUTHORIZING THE COUNTY TO ENTER INTO AN AGREEMENT THROUGH A MEMORANDUM OF AGREEMENT FOR A THREE (3) MONTH PERIOD WITH HORIZON NEW JERSEY HEALTH FOR MEDICAID MANAGED CARE COMMENCING JULY 1, 2014 THROUGH SEPTEMBER 30, 2014, ALL AS NOTED IN THE RESOLUTION

THIS RESOLUTION WAS REQUESTED BY:

REVIEWED BY:

Anthony J. De Nova III  
COUNTY ADMINISTRATOR

APPROVED AS TO FORM AND LEGALITY:

William J. Pascrell, III, Esq.  
COUNTY COUNSEL

Human Services

COMMITTEE NAME

Official Resolution#		R20140209					
Meeting Date		03/25/2014					
Introduced Date		03/25/2014					
Adopted Date		03/25/2014					
Agenda Item		I-10					
CAF #							
Purchase Req. #							
Result		Adopted					
FREEHOLDER	PRES.	ABS.	MOVE	SEC	AYE	NAY	ABST.
Lepore	✓				✓		
Best Jr	✓		✓		✓		
Bartlett	✓			✓	✓		
Cotroneo	✓				✓		
Duffy	✓				✓		
James	✓				✓		
Lora	✓				✓		

PRES.= present ABS.= absent  
MOVE= moved SEC= seconded  
AYE= yes NAY= no ABST.= abstain

Dated: March 26, 2014

**RESOLUTION AUTHORIZING THE COUNTY TO ENTER INTO  
AN AGREEMENT THROUGH A MEMORANDUM OF  
AGREEMENT FOR A THREE (3) MONTH PERIOD WITH  
HORIZON NEW JERSEY HEALTH FOR MEDICAID MANAGED  
CARE COMMENCING JULY 1, 2014 THROUGH SEPTEMBER  
30, 2014**

**WHEREAS** Preakness Healthcare Center is a place of caring and care giving with a long, historical tradition of serving the ever-increasing needs of the citizens of Passaic County; and

**WHEREAS** the Board of Chosen Freeholders of the County of Passaic is desirous of entering into an Agreement through a Memorandum of Agreement for a three (3) month period with Horizon New Jersey Health for Medicaid Managed Care commencing July 1, 2014 through September 30, 2014; and

**WHEREAS** this matter was reviewed and approved by the Human Services Committee on March 13, 2014;

**NOW THEREFORE BE IT RESOLVED** that the Board of Chosen Freeholders of the County of Passaic hereby authorizes the County to enter into an Agreement through a Memorandum of Agreement for a three (3) month period with Horizon New Jersey Health for Medicaid Managed Care commencing July 1, 2014 through September 30, 2014.

JDP:lc

Dated: March 25, 2014



**COUNTY OF PASSAIC  
RESOLUTION REQUEST FORM**

1. NAME OF REQUESTER: Lucinda Corrado  
Telephone #: 973-585-2132

DESCRIPTION OF RESOLUTION: Request to enter into an Agreement through a Memorandum of Agreement for a 3 month period with Horizon New Jersey Health for Medicaid Managed Care.

2. CERTIFICATION INFORMATION:

ATTACH A COPY OF THE REQUISITION FROM EDMUNDS

PLEASE NOTE THAT RESOLUTIONS FOR ALL CONTRACT AWARDS AND OTHER EXPENDITURES REQUIRE A REQUISITION. RESOLUTION REQUESTS FOR EXPENDITURES WILL NOT BE CONSIDERED WITHOUT A REQUISITION NUMBER

3. AMOUNT OF EXPENDITURE: \$ NA  
REQUISITION # N/A  
ACCOUNT# N/A

4. COMMITTEE REVIEW: DATE
- |   |       |
|---|-------|
| <input type="checkbox"/> Administration & Finance                   | _____ |
| <input type="checkbox"/> Public Works / Buildings & Grounds         | _____ |
| <input type="checkbox"/> Planning & Economic Development            | _____ |
| <input type="checkbox"/> Health, Human Services & Community Affairs | _____ |
| <input type="checkbox"/> Law & Public Safety                        | _____ |
| <input type="checkbox"/> Energy                                     | _____ |
| <input type="checkbox"/> Other Specify: _____                       | _____ |

5. DISTRIBUTION LIST:
- Administration
  - Finance
  - Counsel
  - Clerk to the Board
  - Procurement

Specify:  
\_\_\_\_\_

# Passaic County Board of Chosen Freeholders

OFFICE OF THE  
PASSAIC COUNTY FREEHOLDERS

Director Pasquale "Pat" Lepore  
Deputy Director Theodore O. Best, Jr.  
John W. Bartlett  
Ronda Casson Cotroneo  
Terry Duffy  
Bruce James  
Hector C. Lora

401 Grand Street  
Paterson, New Jersey 07505

Tel: 973-881-4402  
Fax: 973-742-3746

Anthony J. De Nova III

Administrator

William J. Pascrell, III, Esq.

County Counsel

Louis E. Imhof, III, RMC

Clerk Of The Board



## Public Meeting (Board Meeting)

Date: Mar 25, 2014 - 5:30 PM

Location: County Administration  
220  
401 Grand Street  
Paterson, NJ 07505

Agenda: RESOLUTION AUTHORIZING THE PAYMENT TO CERTAIN VENDORS OF THE WEATHERIZATION PROGRAM THAT HAVE BY THEIR EMERGENT NATURE EXCEEDED THE COUNTY'S BID THRESHOLD, ALL AS NOTED IN THE RESOLUTION

THIS RESOLUTION WAS REQUESTED BY:

REVIEWED BY:

Anthony J. De Nova III  
COUNTY ADMINISTRATOR

APPROVED AS TO FORM AND LEGALITY:

William J. Pascrell, III, Esq.  
COUNTY COUNSEL

Human Services

COMMITTEE NAME

<b>Official Resolution#</b>	<b>R20140210</b>						
Meeting Date	03/25/2014						
Introduced Date	03/25/2014						
Adopted Date	03/25/2014						
Agenda Item	I-11						
CAF #	G-01-041-833 -011-213						
Purchase Req. #	R4-02083						
Result	Adopted						
<b>FREEHOLDER</b>	<b>PRES.</b>	<b>ABS.</b>	<b>MOVE</b>	<b>SEC</b>	<b>AYE</b>	<b>NAY</b>	<b>ABST.</b>
Lepore	✓				✓		
Best Jr	✓		✓		✓		
Bartlett	✓			✓	✓		
Cotroneo	✓				✓		
Duffy	✓				✓		
James	✓				✓		
Lora	✓				✓		

PRES.= present ABS.= absent  
MOVE= moved SEC= seconded  
AYE= yes NAY= no ABST.= abstain

Dated: March 26, 2014

**RESOLUTION AUTHORIZING THE PAYMENT TO CERTAIN VENDORS OF THE WEATHERIZATION PROGRAM THAT HAVE BY THEIR EMERGENT NATURE EXCEEDED THE COUNTY'S BID THRESHOLD**

**WHEREAS** the Passaic County Weatherization Program in order to fulfill their mission set forth in their grant agreement; and

**WHEREAS** repairs are needed to be made in order to maintain a safe environment for the clients of weatherization; the aggregate costs of said goods and services required by the County exceeds \$17,500.00 and is therefore subject to the requirements of the "Pay to Play" law; and

**WHEREAS** the said Board, by Resolution R-06-97 dated February 14, 2006 established a policy of only awarding contracts in excess of the monetary threshold set forth under the "Pay to Play" Law only under a "Fair and Open" process; and

**WHEREAS** the Board is desirous of making an exception to that policy because of the urgent nature of this case; and

**WHEREAS** the local Public Contract Law, N.J.S.A. 40A:11-1 et seq., requires that the resolution authorizing the award of contract for exempt be available for public inspection; and

**WHEREAS** the Human Services Committee reviewed the matter at its meeting of March 13, 2014 and recommended that this agreement be awarded as with the understanding that the recipient has not made or will make political contributions as set forth under the Campaign Contributions and Expenditures Reporting Act (N.J.S.A. 19:44A-1); and

**WHEREAS** the total sum to be paid to this vendor is as follows:

CPC ENERGY	\$9,700.00
------------	------------

**WHEREAS** a certification is attached which indicates that funds are available for the within contemplated expenditure;

**WHEREAS** the requisition from the EDMUNDS system for the vendor is attached;

**NOW THEREFORE BE IT RESOLVED** by the Board of Chosen Freeholders of the County of Passaic that it hereby authorizes the payment of lump sum amount to CPC Energy in the amount of \$9,700.00 for the work performed on the attached requisition; and

**BE IT FURTHER RESOLVED** that this contract is being awarded as an exception to the policy of the Board as set forth in its Resolution R-06-97 dated February 14, 2006 because of the special circumstances of this situation, and the policy of the Board as set forth in this resolution shall remain in full force and effect; and

**BE IT FURTHER RESOLVED** that all effected officers and employees be and hereby are authorized and directed to take such actions and execute such documents as are necessary to effectuate the purposes of this resolution, including issuance of purchase orders as necessary; and

**BE IT FURTHER RESOLVED** that a Notice of this action be published in the NORTH JERSEY HERALD & NEWS.

JDP: lc

Dated: March 25, 2014

CERTIFICATION OF AVAILABLE FUNDS

THIS IS TO CERTIFY THAT FUNDS ARE AVAILABLE AS FOLLOWS:

AMOUNT: \$9,700.00

APPROPRIATION: G-01-41-833-011-213

PURPOSE: To authorize the payment to CPC Energy, Inc. of the Weatherization Program that have by their emergent nature exceeded the County's bid threshold.

  
Michael Katz, County Treasurer

DATED: February 25, 2014





<p>16. a. Will any member of the Board of Directors/Trustees receive any direct or indirect personal or monetary gain from the funding of this grant?  <input type="checkbox"/> Yes <input type="checkbox"/> No</p> <p>b. Does any member of the Board of Directors/Trustees serve on any board, council commission, committee or task force which has regulatory or advising influence on the funding program? <input type="checkbox"/> Yes <input type="checkbox"/> No                  If yes, please describe:</p>		
<p>17. Fiscal Contact Person Mr. Richard Cahill</p>	<p>Title CFO</p>	<p>Phone Number (973) 881-4432</p>
<p>18. Agency Fiscal Year 01/01 to 12/31</p>	<p>19. Name of CPA Firm Appointed by Grantee</p>	
<p>20. <b>Certification:</b> The applicant certifies that to the best of his/her knowledge and belief all data supplied in this application and attachments are true and correct. The document has been duly authorized by the governing body of the applicant and further understands and agrees that any grant received as a result of this application shall be subject to the grant conditions and other policies, regulation, and rules issued by the New Jersey Department of Community Affairs which include provisions described in grant applications instructions.</p>		
<p>Name and Title of Applicant (Print)</p>	<p>Signature of Applicant</p>	<p>Date of Application</p>



COUNTY OF PASSAIC  
 CO OF PASSAIC, (Q)973-569-4060  
 ENERGY & WEATHERIZATION/SENIOR  
 930 RIVERVIEW DR SUITE 200  
 TOTOWA, NJ 07512

REQUISITION	
NO.	R4-02083

SHIP TO	
VENDOR	VENDOR #: 10832 CPC ENERGY, INC. D/B/A ALLIANCE FUEL COMPANY 469 LYONS AVENUE NEWARK, NJ 07112

ORDER DATE: 03/05/14  
 DELIVERY DATE:  
 STATE CONTRACT:  
 F.O.B. TERMS:

QTY/UNIT	DESCRIPTION	ACCOUNT NO.	UNIT PRICE	TOTAL COST
1.00	HIP 2010 CLINE, KHALILAH INVOICE #4853 DATED: 11/26/13	G-01-41-833-011-213	4,800.0000	4,800.00
1.00	HIP 2010 OWENS, WILLIE INVOICE #4854 DATED: 11/26/13	G-01-41-833-011-213	4,900.0000	4,900.00
	HIP 2011			
			TOTAL	9,700.00

Introduced on: March 25, 2014  
 Adopted on: March 25, 2014  
 Official Resolution#: R20140210

REQUESTING DEPARTMENT      3/5/14      DATE

# Passaic County Board of Chosen Freeholders

OFFICE OF THE  
PASSAIC COUNTY FREEHOLDERS

Director Pasquale "Pat" Lepore  
Deputy Director Theodore O. Best, Jr.  
John W. Bartlett  
Ronda Casson Cotroneo  
Terry Duffy  
Bruce James  
Hector C. Lora

401 Grand Street  
Paterson, New Jersey 07505  
Tel: 973-881-4402  
Fax: 973-742-3746

Anthony J. De Nova III  
*Administrator*  
William J. Pascrell, III, Esq.  
*County Counsel*  
Louis E. Imhof, III, RMC  
*Clerk Of The Board*



## Public Meeting (Board Meeting)

Date: Mar 25, 2014 - 5:30 PM

Location: County Administration  
220  
401 Grand Street  
Paterson, NJ 07505

Agenda: RESOLUTION AUTHORIZING THE FREEHOLDER BOARD TO ENTER INTO A LETTER OF AGREEMENT FOR THREE MONTH EXTENSION FOR ENTERAL NUTRITION SERVICES DURING RFP PROCESS R-11-409, ALL AS NOTED IN THE RESOLUTION

THIS RESOLUTION WAS REQUESTED BY:

REVIEWED BY:

Anthony J. De Nova III  
COUNTY ADMINISTRATOR

APPROVED AS TO FORM AND LEGALITY:

William J. Pascrell, III, Esq.  
COUNTY COUNSEL

Human Services

COMMITTEE NAME

<b>Official Resolution#</b>	<b>R20140211</b>						
Meeting Date	03/25/2014						
Introduced Date	03/25/2014						
Adopted Date	03/25/2014						
Agenda Item	I-12						
CAF #							
Purchase Req. #							
Result	Adopted						
<b>FREEHOLDER</b>	<b>PRES.</b>	<b>ABS.</b>	<b>MOVE</b>	<b>SEC</b>	<b>AYE</b>	<b>NAY</b>	<b>ABST.</b>
Lepore	✓				✓		
Best Jr	✓		✓		✓		
Bartlett	✓			✓	✓		
Cotroneo	✓				✓		
Duffy	✓				✓		
James	✓				✓		
Lora	✓				✓		

PRES.= present ABS.= absent  
MOVE= moved SEC= seconded  
AYE= yes NAY= no ABST.= abstain

Dated: March 26, 2014

**RESOLUTION AUTHORIZING THE FREEHOLDER BOARD TO ENTER INTO A LETTER OF AGREEMENT FOR THREE MONTH EXTENSION FOR ENTERAL NUTRITION SERVICES DURING RFP PROCESS R-11-409**

**WHEREAS** Preakness Healthcare Center is a place of caring and care giving with a long, historical tradition of serving the ever-increasing needs of the citizens of Passaic County; and

**WHEREAS** the Board of Chosen Freeholders of the County of Passaic is desirous of entering into a Letter of Agreement for three month extension for Enteral Nutrition Services during RFP Process R-11-409; and

**WHEREAS** this matter was reviewed and approved by the Human Services Committee on March 13, 2014;

**NOW THEREFORE BE IT RESOLVED** that the Board of Chosen Freeholders of the County of Passaic hereby authorizes the County to enter into a Letter of Agreement for three month extension for Enteral Nutrition Services during RFP Process R-11-409.

JDP:lc

Dated: March 25, 2014

COUNTY OF PASSAIC  
RESOLUTION REQUEST FORM

1. NAME OF REQUESTER: Lucinda Corrado  
Telephone #: 973-585-2132

DESCRIPTION OF RESOLUTION: Request to enter into Letter of Agreement for three month extension of enteral nutrition services during RFP process. R-11-409

2. CERTIFICATION INFORMATION:

ATTACH A COPY OF THE REQUISITION FROM EDMUNDS

PLEASE NOTE THAT RESOLUTIONS FOR ALL CONTRACT AWARDS AND OTHER EXPENDITURES REQUIRE A REQUISITION. RESOLUTION REQUESTS FOR EXPENDITURES WILL NOT BE CONSIDERED WITHOUT A REQUISITION NUMBER

3. AMOUNT OF EXPENDITURE: \$ 16,000  
REQUISITION # To be determined  
ACCOUNT# 4-01-27-172-001-F04

4. COMMITTEE REVIEW:	<u>DATE</u>
<input type="checkbox"/> Administration & Finance	_____
<input type="checkbox"/> Public Works / Buildings & Grounds	_____
<input type="checkbox"/> Planning & Economic Development	_____
<input type="checkbox"/> Health, Human Services & Community Affairs	_____
<input type="checkbox"/> Law & Public Safety	_____
<input type="checkbox"/> Energy	_____
<input type="checkbox"/> Other Specify: _____	_____

5. DISTRIBUTION LIST:  
 Administration  
 Finance  
 Counsel  
 Clerk to the Board  
 Procurement

Specify:  
\_\_\_\_\_



# Passaic County Board of Chosen Freeholders

OFFICE OF THE  
PASSAIC COUNTY FREEHOLDERS

Director Pasquale "Pat" Lepore  
Deputy Director Theodore O. Best, Jr.  
John W. Bartlett  
Ronda Casson Cotroneo  
Terry Duffy  
Bruce James  
Hector C. Lora

401 Grand Street  
Paterson, New Jersey 07505

Tel: 973-881-4402  
Fax: 973-742-3746

Anthony J. De Nova III

Administrator

William J. Pascrell, III, Esq.

County Counsel

Louis E. Imhof, III, RMC

Clerk Of The Board



## Public Meeting (Board Meeting)

Date: Mar 25, 2014 - 5:30 PM

Location: County Administration  
220  
401 Grand Street  
Paterson, NJ 07505

Agenda: RESOLUTION AUTHORIZING THE FREEHOLDER BOARD TO ENTER INTO A LETTER OF AGREEMENT FOR THREE MONTH EXTENSION FOR PHARMACY SERVICES DURING RFP PROCESS R-09-50, ALL AS NOTED IN THE RESOLUTION

THIS RESOLUTION WAS REQUESTED BY:

REVIEWED BY:

Anthony J. De Nova III  
COUNTY ADMINISTRATOR

APPROVED AS TO FORM AND LEGALITY:

William J. Pascrell, III, Esq.  
COUNTY COUNSEL

Human Services

COMMITTEE NAME

<b>Official Resolution#</b>	<b>R20140212</b>						
Meeting Date	03/25/2014						
Introduced Date	03/25/2014						
Adopted Date	03/25/2014						
Agenda Item	I-13						
CAF #							
Purchase Req. #							
Result	Adopted						
<b>FREEHOLDER</b>	<b>PRES.</b>	<b>ABS.</b>	<b>MOVE</b>	<b>SEC</b>	<b>AYE</b>	<b>NAY</b>	<b>ABST.</b>
Lepore	✓				✓		
Best Jr	✓		✓		✓		
Bartlett	✓			✓	✓		
Cotroneo	✓				✓		
Duffy	✓				✓		
James	✓				✓		
Lora	✓				✓		

PRES.= present ABS.= absent  
MOVE= moved SEC= seconded  
AYE= yes NAY= no ABST.= abstain

Dated: March 26, 2014

**RESOLUTION AUTHORIZING THE FREEHOLDER BOARD TO  
ENTER INTO A LETTER OF AGREEMENT FOR THREE MONTH  
EXTENSION FOR PHARMACY SERVICES DURING RFP  
PROCESS R-09-50**

**WHEREAS** Preakness Healthcare Center is a place of caring and care giving with a long, historical tradition of serving the ever-increasing needs of the citizens of Passaic County; and

**WHEREAS** the Board of Chosen Freeholders of the County of Passaic is desirous of entering into a Letter of Agreement for three month extension for Pharmacy Services during RFP Process R-09-50; and

**WHEREAS** this matter was reviewed and approved by the Human Services Committee on March 13, 2014;

**NOW THEREFORE BE IT RESOLVED** that the Board of Chosen Freeholders of the County of Passaic hereby authorizes the County to enter into a Letter of Agreement for three month extension for Pharmacy Services during RFP Process R-09-50.

JDP:lc

Dated: March 25, 2014

**COUNTY OF PASSAIC  
RESOLUTION REQUEST FORM**

1. NAME OF REQUESTER: Lucinda Corrado  
Telephone #: 973-585-2132

DESCRIPTION OF RESOLUTION: Request to enter into Letter of Agreement for three month extension for Pharmacy Service during RFP process. R-09-50

2. CERTIFICATION INFORMATION:

ATTACH A COPY OF THE REQUISITION FROM EDMUNDS

PLEASE NOTE THAT RESOLUTIONS FOR ALL CONTRACT AWARDS AND OTHER EXPENDITURES REQUIRE A REQUISITION. RESOLUTION REQUESTS FOR EXPENDITURES WILL NOT BE CONSIDERED WITHOUT A REQUISITION NUMBER

3. AMOUNT OF EXPENDITURE: \$105,000.00  
REQUISITION # To be determined  
ACCOUNT# 4-01-27-172-001-M01

4. COMMITTEE REVIEW:

DATE

Administration & Finance

\_\_\_\_\_

Public Works / Buildings & Grounds

\_\_\_\_\_

Planning & Economic Development

\_\_\_\_\_

Health, Human Services & Community Affairs

\_\_\_\_\_

Law & Public Safety

\_\_\_\_\_

Energy

\_\_\_\_\_

Other Specify: \_\_\_\_\_

\_\_\_\_\_

5. DISTRIBUTION LIST:

Administration

Finance

Counsel

Clerk to the Board

Procurement

Specify:

\_\_\_\_\_

# Passaic County Board of Chosen Freeholders

OFFICE OF THE  
PASSAIC COUNTY FREEHOLDERS

Director Pasquale "Pat" Lepore  
Deputy Director Theodore O. Best, Jr.  
John W. Bartlett  
Ronda Casson Cotroneo  
Terry Duffy  
Bruce James  
Hector C. Lora

401 Grand Street  
Paterson, New Jersey 07505

Tel: 973-881-4402  
Fax: 973-742-3746

Anthony J. De Nova III

Administrator

William J. Pascrell, III, Esq.

County Counsel

Louis E. Imhof, III, RMC

Clerk Of The Board



## Public Meeting (Board Meeting)

Date: Mar 25, 2014 - 5:30 PM

Location: County Administration  
220  
401 Grand Street  
Paterson, NJ 07505

Agenda: RESOLUTION AUTHORIZING THE SUBMISSION OF AN APPLICATION TO NEW JERSEY TRANSIT FOR THREE MINI-BUSES WITH LIFTS TO PROVIDE TRANSPORTATION TO RESIDENTS OF PREAKNESS HEALTHCARE CENTER (SENIOR CITIZENS AND PEOPLE WITH DISABILITIES) UNDER A GRANT, NEW JERSEY TRANSIT FTA, 5310, ALL AS NOTED IN THE RESOLUTION

THIS RESOLUTION WAS REQUESTED BY:

REVIEWED BY:

Anthony J. De Nova III  
COUNTY ADMINISTRATOR

APPROVED AS TO FORM AND LEGALITY:

William J. Pascrell, III, Esq.  
COUNTY COUNSEL

Human Services

COMMITTEE NAME

Official Resolution#		R20140213						
Meeting Date		03/25/2014						
Introduced Date		03/25/2014						
Adopted Date		03/25/2014						
Agenda Item		I-14						
CAF #								
Purchase Req. #								
Result		Adopted						
FREEHOLDER	PRES.	ABS.	MOVE	SEC	AYE	NAY	ABST.	
Lepore	✓				✓			
Best Jr	✓		✓		✓			
Bartlett	✓			✓	✓			
Cotroneo	✓				✓			
Duffy	✓				✓			
James	✓				✓			
Lora	✓				✓			

PRES.= present ABS.= absent  
MOVE= moved SEC= seconded  
AYE= yes NAY= no ABST.= abstain

Dated: March 26, 2014



**RESOLUTION AUTHORIZING THE SUBMISSION OF AN APPLICATION TO NEW JERSEY TRANSIT FOR THREE MINI-BUSES WITH LIFTS TO PROVIDE TRANSPORTATION TO RESIDENTS OF PREAKNESS HEALTHCARE CENTER (SENIOR CITIZENS AND PEOPLE WITH DISABILITIES) UNDER A GRANT, NEW JERSEY TRANSIT FTA, 5310**

**WHEREAS** Preakness Healthcare Center is a place of caring and care giving with a long, historical tradition of serving the ever-increasing needs of the citizens of Passaic County; and

**WHEREAS** the Board of Chosen Freeholders of the County of Passaic is desirous of submitting an application to New Jersey Transit for three mini-buses with lifts to provide transportation to residents of Preakness Healthcare Center (Senior Citizens and people with disabilities) under a grant, New Jersey Transit FTA, 5310; and

**WHEREAS** this matter was reviewed and approved by the Human Services Committee on March 13, 2014;

**NOW THEREFORE BE IT RESOLVED** that the Board of Chosen Freeholders of the County of Passaic hereby authorizes the submission of an application to New Jersey Transit for three mini-buses with lifts to provide transportation to residents of Preakness Healthcare Center (Senior Citizens and people with disabilities) under a grant, New Jersey Transit FTA, 5310.

JDP:lc

Dated: March 25, 2014

**COUNTY OF PASSAIC  
RESOLUTION REQUEST FORM**

1. NAME OF REQUESTER: Lucinda Corrado  
Telephone #: 973-585-2132

DESCRIPTION OF RESOLUTION: Request to submit application to New Jersey Transit for three mini-buses with lifts to provide transportation to residents of Preakness Healthcare Center (senior citizens and people with disabilities) under a grant, New Jersey Transit, FTA, 5310.

2. CERTIFICATION INFORMATION:

ATTACH A COPY OF THE REQUISITION FROM EDMUNDS

PLEASE NOTE THAT RESOLUTIONS FOR ALL CONTRACT AWARDS AND OTHER EXPENDITURES REQUIRE A REQUISITION. RESOLUTION REQUESTS FOR EXPENDITURES WILL NOT BE CONSIDERED WITHOUT A REQUISITION NUMBER

3. AMOUNT OF EXPENDITURE: \$ NA  
REQUISITION # N/A  
ACCOUNT# N/A

4. COMMITTEE REVIEW:	<u>DATE</u>
<input type="checkbox"/> Administration & Finance	_____
<input type="checkbox"/> Public Works / Buildings & Grounds	_____
<input type="checkbox"/> Planning & Economic Development	_____
<input type="checkbox"/> Health, Human Services & Community Affairs	_____
<input type="checkbox"/> Law & Public Safety	_____
<input type="checkbox"/> Energy	_____
<input type="checkbox"/> Other Specify: _____	_____

5. DISTRIBUTION LIST:  
 Administration  
 Finance  
 Counsel  
 Clerk to the Board  
 Procurement  
 Specify: \_\_\_\_\_

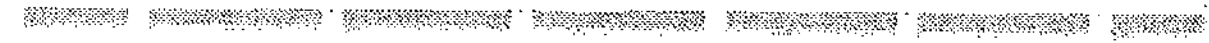

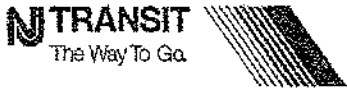

**SECTION 5310  
NEW JERSEY STANDARD ASSURANCES**

Legal Name of Organization: \_\_\_\_\_

The applicant organization hereby agrees to the following Standard Assurances pursuant to the Section 5310 program.

1. It will comply with all applicable provisions with the NJ TRANSIT Standards for Section 5310. (Lease, insurance and reporting requirements)
2. It will give FTA and the Comptroller General, through any authorized representative, access to and the right to examine all records, books, papers, or documents related to the grant.
3. It will operate and maintain any facility or equipment constructed or purchased as part of a federal grant in accordance with the minimum standards as may be required or prescribed by the applicable federal, state and local agencies for the maintenance and operation of such facilities.
4. It recognizes NJ TRANSIT's authority to conduct audits for the purpose of verifying compliance with the requirements and stipulations stated above.
5. Based on information submitted in the applicant organization's application, the service provided or offered to be provided by existing public or private transit operators is unavailable, insufficient or inappropriate to meet the special needs of elderly or persons with disabilities within the service area.
6. The applicant organization possesses the necessary fiscal and managerial capability to implement and manage its proposed project.
7. The applicant organization is considered under state law as a private non-profit and has the legal capacity to contract with the state to carry out the proposed project or is a local government recognized by the state as an eligible local government under this program.
8. The applicant organization has or will have the time of delivery sufficient funds to operate the vehicle(s) equipment to be purchased under this project.
9. It will submit if selected any and all certifications required by state and/or federal law.

Signature of Authorized Official: \_\_\_\_\_

Print Name: \_\_\_\_\_

Title of Authorized Official: \_\_\_\_\_

Date: \_\_\_\_\_



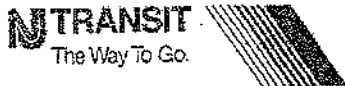

NJ TRANSIT FTA 5310 PART II APPLICATION

Public Notice Requirements

Applicants must publish a notice in a newspaper of general circulation on two separate days, placed in newspaper in the proposed service area. As per the FTA there must be an opportunity for public review and comment for all FTA funded capital and operating requests (projects). To comply with this requirement all Section 5310 subrecipients requesting a capital project (vehicle and/or mobility management project) and/or operating project must do a public notice in a newspaper soliciting public comment. A public hearing is only required if the project affects significant economic, social or environmental interests.

SAMPLE PUBLIC NOTICE

Notice is hereby given that \_\_\_\_\_ has made application to  
Agency Name

NJ TRANSIT for \_\_\_\_\_ to assist in providing  
# and type of vehicles, MM and /or operating project

transportation to senior citizens and/or people with disabilities in \_\_\_\_\_, New Jersey.  
Indicate service area

This project will be partially funded with FTA 5310 funds under a grant submitted to the Federal Transit Administration.

Any interested party who has a significant, social, economic or environmental interest is invited to provide comments within 30 days to:

\_\_\_\_\_  
(Name of Applicant)

\_\_\_\_\_  
(Address)

PLEASE NOTE:

*When returning application, please include: Original notarized copies of Public Notices that actually appeared in the newspaper, on two separate days. (Raised seal not required as long as the newspapers provide a certification and proof of publication.)*

# Passaic County Board of Chosen Freeholders

OFFICE OF THE  
PASSAIC COUNTY FREEHOLDERS

Director Pasquale "Pat" Lepore  
Deputy Director Theodore O. Best, Jr.  
John W. Bartlett  
Ronda Casson Cotroneo  
Terry Duffy  
Bruce James  
Hector C. Lora

401 Grand Street  
Paterson, New Jersey 07505

Tel: 973-881-4402  
Fax: 973-742-3746

Anthony J. De Nova III

Administrator

William J. Pascrell, III, Esq.

County Counsel

Louis E. Imhof, III, RMC

Clerk Of The Board



## Public Meeting (Board Meeting)

Date: Mar 25, 2014 - 5:30 PM

Location: County Administration  
220  
401 Grand Street  
Paterson, NJ 07505

Agenda: RESOLUTION AUTHORIZING THE RE-APPOINTMENTS OF JANICE SANGEL, ANN LONG, LOIS HAMILTON, JOAN LYNKAK, LINDA WILSON, CINDY SIMON, JUDY GIURINTANO TO THE PASSAIC COUNTY ADVISORY COUNCIL ON DISABILITY FOR A THREE-YEAR TERM, ALL AS NOTED IN THE RESOLUTION

THIS RESOLUTION WAS REQUESTED BY:

REVIEWED BY:

Anthony J. De Nova III  
COUNTY ADMINISTRATOR

APPROVED AS TO FORM AND LEGALITY:

William J. Pascrell, III, Esq.  
COUNTY COUNSEL

Human Services

COMMITTEE NAME

Official Resolution#	R20140214						
Meeting Date	03/25/2014						
Introduced Date	03/25/2014						
Adopted Date	03/25/2014						
Agenda Item	I-15						
CAF #							
Purchase Req. #							
Result	Adopted						
FREEHOLDER	PRES.	ABS.	MOVE	SEC	AYE	NAY	ABST.
Lepore	✓				✓		
Best Jr	✓		✓		✓		
Bartlett	✓			✓	✓		
Cotroneo	✓				✓		
Duffy	✓				✓		
James	✓				✓		
Lora	✓				✓		

PRES.= present ABS.= absent  
MOVE= moved SEC= seconded  
AYE= yes NAY= no ABST.= abstain

Dated: March 26, 2014

**RESOLUTION AUTHORIZING THE RE-APPOINTMENTS OF  
JANICE SANGEL, ANN LONG, LOIS HAMILTON, JOAN  
LYNYAK, LINDA WILSON, CINDY SIMON, JUDY GIURINTANO  
TO THE PASSAIC COUNTY ADVISORY COUNCIL ON  
DISABILITY FOR A THREE-YEAR TERM**

**WHEREAS** the Board of Chosen Freeholders of the County of Passaic, by Resolution adopted on the date of May 21, 1997, created the Advisory Council on Disability in Passaic County; and

**WHEREAS** the Board of Chosen Freeholders is desirous of re-appointing the following members to the aforesaid Advisory Council:

*Janice Sangel, resident of West Milford  
Ann Long, representative Spectrum for Living  
Lois Hamilton, resident of Oak Ridge  
Joan Lynyak, resident of Clifton  
Linda Wilson, resident Preakness Health Care Center  
Cindy Simon, resident of Wayne  
Judy Giurintano, resident of Paterson*

**WHEREAS** the aforesaid matter was reviewed and approved by the Freehold Human Services Committee on March 13, 2014;

**NOW THEREFORE BE IT RESOLVED** by the Board of Chosen Freeholders of the County of Passaic that it hereby reappoints Janice Sangel, Ann Long, Lois Hamilton, Joan Lynyak, Linda Wilson, Cindy Simon and Judy Giurintano to the Passaic County Advisory Council on Disability to a term of three (3) years commencing immediately and expiring March 31, 2017.

JDP:lc

Dated: March 25, 2014

## COUNTY OF PASSAIC RESOLUTION REQUEST FORM

1. NAME OF REQUESTER: **Mary Kuzinski**  
Telephone #: **973-569-4070**

DESCRIPTION OF RESOLUTION: Resolution authorizing the re-appointments of Janice Sangel, Ann Long, Lois Hamilton, Joan Lynyak, Linda Wilson, Cindy Simon, Judy Giurintano to the Passaic County Advisory Council on Disability for a three-year term.

Whereas the total sum to be paid are as follows:

2. CERTIFICATION INFORMATION

ATTACH A COPY OF *THE REQUISITION FROM EDMUNDS*

PLEASE NOTE THAT RESOLUTIONS FOR ALL CONTRACT AWARDS AND OTHER EXPENDITURES REQUIRE A *REQUISITION*. RESOLUTION REQUESTS FOR EXPENDITURES WILL NOT BE CONSIDERED WITHOUT A REQUISITION NUMBER

3. AMOUNT OF EXPENDITURE:  
4. BUDGET ACCOUNT:  
5. COMMITTEE REVIEW:

DATE

<input type="checkbox"/> Administration & Finance	_____
<input type="checkbox"/> Public Works / Buildings & Grounds	_____
<input type="checkbox"/> Planning & Economic Development	_____
<input type="checkbox"/> Health, Human Services & Community Affairs	_____
<input type="checkbox"/> Law & Public Safety	_____
<input type="checkbox"/> Energy	_____
<input type="checkbox"/> Other Specify: _____	_____

6. DISTRIBUTION LIST:

Administration  
 Finance  
 Counsel  
 Clerk to the Board  
 Procurement

Specify:

\_\_\_\_\_

Janice L. Sangle  
236 Bearfort Road  
West Milford, NJ 07480

Tel. (973) 728-1282  
Fax. (973) 728-7566  
Email: Jsangle@optonline.net

Biographic Summary  
West Milford Township  
West Milford, New Jersey

1996 -- to present Medical Representative, West Milford Americans with Disabilities Act Compliance Committee.

1997 - 2002 Founder, Community Outreach Program for people with disabilities in West Milford Township. Initiated a program to assist seniors and people with disabilities in conjunction with the Passaic County Probation Department. Community Services workers build ramps for individuals with mobility impairments, also yard cleanup and minor maintenance.

National Multiple Sclerosis Society  
Greater North Jersey Chapter  
Paramus, New Jersey

1995-- to present, Peer Counselor and Facilitator for the National MS Society Greater North Jersey Chapter.  
Founder and Support Group Leader to the "Squeaky Wheels"  
Co-Chair Government Relations Committee

1999-to present, Member - NJ CAN, statewide coalition group that monitors issues affecting people with MS, people with chronic illness, and others with disabilities living in New Jersey.

2000-to present, Consultant and trainer to the P.A.V.E. (Project Access: Visibility and Education) programs.

2000-to present, ADA (Americans with Disabilities) Consultant.

Passaic County Advisory Council On Disability  
Department of Human Services  
401 Grand Street  
Paterson, New Jersey 07505

1997 -- 1999 ADA Committee Chairperson

1999 --2001 Chairwomen, responsibilities included overseeing all permanent standing committees, Bylaws, Legislative, ADA and Personal Assistance Services.

Introduced on: March 25, 2014  
Adopted on: March 25, 2014  
Official Resolution # R2910294 Chairwomen, ADA Committee





2003 - to present, Reviewer to the Association of Advancement of Medical Instrumentation (AAMI) Human Factors Engineering Committee. Currently developing a document (HE75) that pertains to guidelines on designing usability in medical devices in the United States. The committee plans to develop the guidelines so that the special needs of different segments of the population are considered at each stage of the design process.  
<http://www.aami.org/committeecentral/>

New Jersey Coalition for Accessibility  
185 Valley Street  
South Orange, NJ 07079

2003 to present, Our mission is to advocate for barrier free accessibility and program accessibility to public accommodations, state and local government facilities and programs, and residential settings.

Passed affiliations:

National Organization On Disability  
910 Sixteenth Street, NW  
Washington, DC 20006

1998 -- 2001, N.O.D. Community Representative for the Township of West Milford.

Northeast Disability and Business Technical Assistance Center  
354 South Broad Street  
Trenton, NJ 08608

1998 - 2001 I served as a Hub site for the Northeast Disability and Business Technical Assistance Center, I disseminate information, technical assistance and training on the Americans with Disabilities Act.

Wayne General Hospital  
Wayne, New Jersey

1990 -- 1995 Medical Surgical Nurse,  
Asst. For Special Children & Families  
West Milford, New Jersey

1982 -- to 2001 Member of the Board of Directors. I also served as President, Vice President and Treasurer.

EPIC (Effective Parenting Information for Children) facilitator

Advocacy Achievements:

2003 Medicaid Dental Benefits - Successfully advocated keeping \$14 million

Introduced on: March 25, 2014  
Adopted on: March 25, 2014  
Official Resolution#: R20140214

in the FY 2004 State Budget for the funding of the Medicaid Dental Program.

2003 NJ Handicapped Parking Fines - Successfully advocated for introduction of a bill to change existing NJ Handicapped Parking fines.

02-03 DMV Manual/Test - Advocating to have accessible parking regulations included in the NJ Driver's Manual and on the Driver's Exam.

02-03 In-Network Benefits - Testified at Assembly Health and Human Services Committee, which resulted in introduction and passage of a bill to provide in-network benefits to patients with disabilities for out-of-network services because of accessibility issues.

2002 Accessible Medical Equip. - Testified at Assembly Health and Human Services Committee, which resulted in introduction and passage of a bill memorializing ANSI to develop standards for accessible medical equipment.

New Jersey - lobbied for the wheelchair lemon law, Office of the Ombudsman for the disabled and snow obstruction of the handicapped parking. I provided testimony to the state assembly (Assembly Bill No. 2427) on county offices on disabled at the state house in Trenton.

Washington DC - On numerous occasions over the years I meet with New Jersey legislators and lobbied for funding of federal medical and rehabilitation research, patient protections and health care quality, privacy of medical records and genetic information and long-term care services, Medicare reform and Prescription Drug coverage, also increase funding to the NIH (National Institute on Health)

Awards received:

The Association for Special Children and Families, 1995, - 1999

The Greater North Jersey Chapter, National Multiple Sclerosis Society, 1996 - 2001

Township of West Milford, New Jersey - Volunteer of the Year, 1999

The National Multiple Sclerosis Society - Achievement Award for Eastern

Introduced on: March 25, 2014  
Adopted on: March 25, 2014  
Official Resolution#: R20140214

The National Multiple Sclerosis Society - National Achievement Award  
for the  
United States, 1999

DIAL Inc. - Independent Living Award, 2000

New Jersey Women of Achievement Award, 2002

National Multiple Sclerosis Society - 2003, Inducted into the National  
Hall  
of Fame

Lois Hamilton

161 Doremus Road

Oak Ridge, NJ 07438

Having been a productive member of the Passaic County Advisory Council for People With Disabilities for over a decade, my current term of service is due to expire at the end of this year. This document serves as a request that I continue to remain on the Council.

A former math teacher for 21 years, I became disabled as a result of spinal cord compression in the late 90's. Progressive weakness eventually led to paralysis and the use of a wheelchair. In 1998, I gave up my full time teaching job, but slowly began seeing students on a one to one basis, tutoring mathematics. This continues to be very rewarding to both my students and me. I am also a certified guidance counselor, following along with my interest in people, especially students.

I learned about the Passaic County Advisory Council, as well as the West Milford ADA Committee and have served on both for many years. I am a client at Push to Walk, a specialized exercise/recovery facility for people with spinal cord injuries and paralysis where I am an available resource to other clients and their families, especially those newly injured. I participate in the many of their fundraising activities throughout the year as sessions are not covered by insurance. Most recently, I hand-cycled in the NJ Marathon as part of Team Push to Walk and volunteered at their 5<sup>th</sup> annual golf outing where I was able to use an accessible golf cart. Additionally, I speak to HS Sociology classes about being disabled as part of their "handicapped" unit. Much of my ability to be part of these and other activities is made possible by the PASP program of which I am a consumer.

Thank you in advance for the opportunity to serve on the Passaic County Advisory Council for People with Disabilities.

LINDA C. WILSON  
231 Van Winkle Avenue  
Hawthorne, NJ 07506  
973-423-0117

### APPOINTMENTS – EXPERIENCES

2000 As Disability Advocate in the Passaic County Division of Family Services, I wrote/submitted grant to U.S. Department of Education, Rehabilitation Services Administration (\$1.365 Million) to improve/expand the availability of various services/programs for Passaic County disability population via partnership initiatives and collaborative/coordinated endeavors of Passaic County agencies (e.g., paratransit, DIAL, Inc., Division of Rehabilitation Services, Workforce Development Center).

1997 As Chair of then newly established Passaic County Advisory Council on Disability, I addressed the motions set forth via membership majority vote that resulted in an ADA training workshop; letters to state/federal officials on Passaic County departmental stationary relevant to council support/opposition of proposed legislation; obtained freeholder support and use of paratransit bus for transport of council members to testify in New Brunswick at public hearing to voice their support of increased funds to acquire a facility for ARC clientele that reside in lower Passaic County.

1995 As a State Commissioner (gubernatorial appointment) serving on the Orthotics and Prosthetics Board of Examiners, I assisted Deputy Attorney General (DAG) in development of licensure regulations to mirror statute of enacted legislation; addressed all aspects of board functions within scope of Division of Consumer Affairs in Department of Law and Public Safety in a responsible manner.

1994 As Chair of NJ Independent Living Council, I directed completion of State Plan that included budgetary recommendations for consumer –governed independent living centers ((e.g., DIAL, Inc.). I also wrote Executive Order to restructure NJ Independent Living Council, as required by Rehabilitation Act 1994 Amendments.

1992 As State sponsored appointee, she was trained/certified by the U.S. Department of Justice to serve on National ADA Consultant Network, which in part assisted/promoted via workshops the importance of ADA compliance.

1990 As consumer member, I served on Human Services Advisory Council at state and county level. Throughout a seven year period, my involvement focused on proposed legislation at the federal/state level that in turn – is directly linked to participatory funding recommendations of Proposal Review Committee as required/presented to Board of Freeholders for their decision /provision of services to Passaic County disability population.

NEW-10-2004 10:31H FROM: Cindy Simon

10:32:184373

P12

**CINDY SIMON**  
33 Knox Ter. 2A  
Wayne, NJ 07470  
(973) 692-0329

**Education**

New York University	Ph.D. candidate
New York University School of Law	J.D. 1996
Eagleton Institute of Politics	M.A. 1994
Rutgers College	B.A. 1992

**Experience**

William Paterson University Spring 1997- present  
Adjunct Professor: teaching classes in political science and law

Passaic County Community College Spring 2001 – present  
Adjunct Professor: Teaching classes in remedial English, reading, and critical thinking.

Passaic County Community College present  
Tutor: Tutoring English and reading

Law Office of Cindy Simon 1/97 – present  
Lawyer: focusing primarily on legal research & writing for other attorneys as well as providing legal advice in the areas of disability and labor law.

**Community Activities**

Trustee, Wayne Board of Education  
Secretary, Wayne Democratic Municipal Committee  
Parliamentarian, Young Democrats of America  
Member, Association of Blind Athletes of NJ governing Board  
Member, Passaic County Advisory Council on Disability  
Chair, Accessibility Committee, Shomrei Torah

JUDITH GIURINTANO  
375 Linwood Ave.  
Paterson, NJ 07502  
Phone (973) 720-8488

Born and raised in Passaic County.

Graduated from Bonadventure High School in 1961.

Worked for Paterson Shipping Company from 1961 to 1970.

Widower--Married for 29 years, one child, one stepchild and three grand children.

Became disabled in 1974.

Serving for the County of Passaic Personal Assistance Services Program Advisory Council on Disability as follows:

PASP Committee	2002 to Present
PASP Alternate for the State Advisory Council on Disability	2002 to Present
ADA Committee	1998 to Present



# Passaic County Board of Chosen Freeholders

OFFICE OF THE  
PASSAIC COUNTY FREEHOLDERS

Director Pasquale "Pat" Lepore  
Deputy Director Theodore O. Best, Jr.  
John W. Bartlett  
Ronda Casson Cotroneo  
Terry Duffy  
Bruce James  
Hector C. Lora

401 Grand Street  
Paterson, New Jersey 07505

Tel: 973-881-4402  
Fax: 973-742-3746

Anthony J. De Nova III

Administrator

William J. Pascrell, III, Esq.

County Counsel

Louis E. Imhof, III, RMC

Clerk Of The Board



## Public Meeting (Board Meeting)

Date: Mar 25, 2014 - 5:30 PM

Location: County Administration  
220  
401 Grand Street  
Paterson, NJ 07505

Agenda: RESOLUTION AUTHORIZING THE APPOINTMENT OF LORI FRIEDMAN TO THE WORKFORCE INVESTMENT BOARD OF PASSAIC COUNTY FOR A TERM OF THREE (3) YEARS COMMENCING IMMEDIATELY AND TERMINATING MARCH 24, 2017, ALL AS NOTED IN THE RESOLUTION

THIS RESOLUTION WAS REQUESTED BY:

REVIEWED BY:

Anthony J. De Nova III  
COUNTY ADMINISTRATOR

APPROVED AS TO FORM AND LEGALITY:

William J. Pascrell, III, Esq.  
COUNTY COUNSEL

Human Services

COMMITTEE NAME

Official Resolution#	R20140215						
Meeting Date	03/25/2014						
Introduced Date	03/25/2014						
Adopted Date	03/25/2014						
Agenda Item	I-16						
CAF #							
Purchase Req. #							
Result	Adopted						
FREEHOLDER	PRES.	ABS.	MOVE	SEC	AYE	NAY	ABST.
Lepore	✓				✓		
Best Jr	✓		✓		✓		
Bartlett	✓			✓	✓		
Cotroneo	✓				✓		
Duffy	✓				✓		
James	✓				✓		
Lora	✓				✓		

PRES.= present ABS.= absent  
MOVE= moved SEC= seconded  
AYE= yes NAY= no ABST.= abstain

Dated: March 26, 2014

**RESOLUTION AUTHORIZING THE APPOINTMENT OF  
LORI FRIEDMAN TO THE WORKFORCE INVESTMENT  
BOARD OF PASSAIC COUNTY FOR A TERM OF THREE  
(3) YEARS COMMENCING IMMEDIATELY AND  
TERMINATING MARCH 24, 2017**

**WHEREAS** the Passaic County Workforce Development Center provides training for unemployed, unskilled and displaced individuals so they can effectively operate in the workplace; and

**WHEREAS** the Freeholder Board is desirous of appointing Lori Friedman of Westfield, NJ, to the Passaic County Workforce Development Center for a term of three years commencing immediately and terminating March 24, 2017; and

**WHEREAS** this matter was reviewed and approved by the Freeholders Standing Committee of Human Services;

**NOW THEREFORE BE IT RESOLVED** that the Board of Chosen Freeholders of the County of Passaic hereby authorizes the appointment of Lori Friedman of Westfield, NJ for a term of three years commencing immediately and terminating March 24, 2017.

JDP: lc

Dated: March 25, 2014

## COUNTY OF PASSAIC RESOLUTION REQUEST FORM

1. NAME OF REQUESTER: Christopher C. Irving, Executive Director  
Telephone #: 973-569-5082

DESCRIPTION OF RESOLUTION:

Recommending the following private sector to be a new member of Workforce Investment Board of Passaic County for a three (3) year term:

➤ Lori Friedman, Vice-President Goodwill of NY/NJ

Please see attached application & resume.

2. CERTIFICATION INFORMATION:

ATTACH A COPY OF ***THE REQUISITION FROM EDMUNDS: N/A***

PLEASE NOTE THAT RESOLUTIONS FOR ALL CONTRACT AWARDS AND OTHER EXPENDITURES REQUIRE A ***REQUISITION***. RESOLUTION REQUESTS FOR EXPENDITURES WILL NOT BE CONSIDERED WITHOUT A REQUISITION NUMBER

3. AMOUNT OF EXPENDITURE: N/A

**REQUISITION #:** N/A  
**ACCOUNT#:** N/A

4. COMMITTEE REVIEW: DATE

<input type="checkbox"/> Administration & Finance	_____
<input type="checkbox"/> Public Works / Buildings & Grounds	_____
<input type="checkbox"/> Planning & Economic Development	_____
<input type="checkbox"/> Health, Human Services & Community Affairs	_____
<input type="checkbox"/> Law & Public Safety	_____
<input type="checkbox"/> Energy	_____
<input type="checkbox"/> Other specify: _____	_____

5. DISTRIBUTION LIST:

Administration  
 Finance  
 Counsel  
 Clerk to the Board

Introduced on: March 20, 2014  Consent specify: \_\_\_\_\_  
Adopted on: March 25, 2014  
Official Resolution#: R20140215



401 Grand Street, Room 417, Paterson, NJ 07505  
PH 973-569-4020 - FAX 973-881-2733  
Everton Scott, Chair

**WIB Member Application**

Thank you for applying to be a member of the Workforce Investment Board of Passaic County, (WIB)

Please complete the following information and submit it to:

Workforce Investment Board of Passaic County  
401 Grand Street, Room 417  
Paterson, NJ 07505  
FAX 973-881-2733

Included in this packet is a fact sheet that provides an overview of the Workforce Investment Board and board member responsibilities. If you have any questions, please contact 973-569-4020.

Date: July 2, 2013

Name: Lori Friedman

Home Address: 115 Oak Tree Pass  
Westfield, NJ 07090

Home Telephone: 908-233-3098

Home Fax: \_\_\_\_\_

Home Email: \_\_\_\_\_

Cell Phone: \_\_\_\_\_

Place of Employment: Goodwill Industries of Greater NY and Northern NJ

Occupation/Position: Senior Vice President

Work Address: 400 Super Boulevard, Harrison, NJ 07029

Work Telephone: 973-474-2021

Work Fax: \_\_\_\_\_

Work Email: LFriedman@goodwillny.org

Do you prefer to be contacted at work  or at home \_\_\_\_\_?

THE COUNTY OF PASSAIC  
2013 JUL 12 AM 9:34  
WIB



401 Grand Street, Room 417, Paterson, NJ 07606  
 PH 973-569-4020 – FAX 973-881-2733  
 Everton Scott, Chair

Nominations to the Workforce Investment Board of Passaic County

To: All Nominating Organizations

Thank you for submitting a nomination for the Workforce Investment Board of Passaic County from your organization. Please complete the information below, have it signed by the individual authorized and attach it to the completed application.

To: The Workforce Investment Board of Passaic County

From:     Lori Friedman     proudly submits the name of     Lori Friedman    

to the Workforce Investment Board of Passaic County for nomination to the Workforce Investment Board of Passaic County.

Signed:     *Lori Friedman*     Title: Senior Vice President Date: 7/2/2013



401 Grand Street, Room 417, Peterson, NJ 07505  
PH 973-589-4020 - FAX 973-881-2733  
Everton Scott, Chair

Please answer all questions with as much pertinent information about yourself as possible. If you need more room for your answers, please attach an additional sheet of paper.

1. List past or present involvement in community-related activities (i.e., committees, volunteer work, boards, business organizations, chambers of commerce, etc.)

Please see attached resume

---



---



---



---

2. Explain your understanding of the purposes, responsibilities and services offered by the WIB.

My understanding of the WIB is that it will provide direction for all workforce services in the county. The WIB serves employers as well as workers. It carries out its work in partnership with all stakeholders to meet the needs of the workforce system. The WIB needs to ensure that the system is responsive, efficient and effective.

List any experiences you feel would be advantageous to the WIB.

Please see attached resume

3. List any past experience in workforce development, economic development (e.g. Workforce Investment Board membership, youth employment/training committees).

Please see attached resume

---



---



---



---

4. References: Please provide two references who can attest to your ability to serve on the WIB. (Name, Address, Phone Number)

- 1) Linda Turner, Executive Vice President, Goodwill Industries of Greater NY and Northern NJ, 21-4 28<sup>th</sup> Avenue, Astoria, NY 718-777-6336
- 2) Solo Okonkwo, Manager, Newark Office, Division of Vocational Rehabilitation Services, NJ Labor and Workforce Development, 990 Broad Street, Newark, NJ 07101

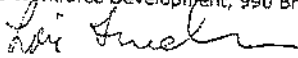
Signature: 

Lozi Friedman  
 400 Supor Boulevard  
 Harrison, NJ 07029  
 973-474-2021  
 LFriedman@goodwillny.org

### Professional Experience

Goodwill Industries, Inc. of Greater NY & NJ, Harrison, NJ, August, 2011 – present  
 Senior Vice President, Northern NJ Division

Responsibilities: Manage, supervise and lead the Northern NJ Division and implement strategic, fiscal and policy initiatives to grow the business in accordance with organizational objectives.

- Administer programs from various funding sources which support the mission
- Main point of contact for all Northern NJ programs and business development
- Ensure compliance with all safety and security policies and service standards within the NJ facility to assure that programs achieve standards and receive accreditation.
- Represent Goodwill Northern NJ Division at all senior staff meetings, board meetings, governmental, business and development meetings.
- Research, design and implement new programs, services and/or social enterprises that support agency goals and objectives.
- Establish and maintain relationships with Northern NJ stakeholders.

Director, Vocational Rehabilitation Services

Responsibilities: Manage and direct Rehabilitation programs for Northern NJ Division.

- Administered a diverse selection of programs that assisted people with disabilities to prepare for, secure and/or maintain employment.
- Developed monthly reports to highlight Rehab activities, monitor revenue/expenses and track client referrals, placement and billable hours.
- Oversight of training programs for skill-building and work readiness
- Established and maintained ongoing relationships with potential referral sources, service providers and community resources.

Belton Hearing Care & Audiology Centers, Florham Park, NJ, April 2010 – August 2011

Director, Marketing and Community Outreach

Responsibilities: Manage marketing, planning & community outreach for health related business.

- Developed and implemented a planning process which resulted in a 30% increase in sales.
- Led community outreach effort in Union, Essex and Morris County which resulted in multidisciplinary partnerships and provision of educational programs for healthcare staff and seniors.
- Established comprehensive management reporting to track performance on key business processes.
- Oversight of marketing plan and community outreach, community events and patient satisfaction.

Jewish Family Service of Central New Jersey, Elizabeth, NJ, August 2008 – December 2009

Project Manager, Naturally Occurring Retirement Community (NORC) Grant

Responsibilities: Managed a \$400K federally funded project for duration of the grant.

- Developed project strategy and executed project plan on-time and within budget.
- Lead evaluator for project, which included quantitative and qualitative measures of success.
- Managed budget and prepared required reporting to the federal government.
- Implemented successful outreach strategy which led to recruitment of 76 community members for the Advisory Board and over 100 community partners.
- Represented the agency at professional meetings on the local, county, state and national level.
- Managed interdisciplinary professional team, interns and volunteers.

Caring Hospice Services, Edison, NJ, September 2007 - August 2008

Manager, Volunteer Services

Responsibilities: Developed and managed Medicare mandated hospice volunteer program.

- Planned innovative hospice volunteer recruitment strategy which resulted in enrollment of forty new volunteers in eight months of implementation and eight new partnerships with volunteer providers.
- Developed comprehensive management reporting resulting in improved tracking and placement.
- Developed training materials and curriculum for volunteers.
- Supervised interns and volunteers

American Express, New York, NY, October 1989 - May 1996

Senior Manager, U.S. Consumer Card Marketing

Responsibilities: Managed baggage insurance product

- Managed customer service, marketing, new product testing and quality assurance. Results included increased cardmember satisfaction and achievement of quality assurance standards.
- Developed staff training programs to support new product roll-outs.
- Oversight of contracted customer service vendor, administrative staff and interns.

Manager, U.S. Consumer Card Operations, October

Responsibilities: Managed U.S. Consumer Card Customer Service Operations projects

- Planned comprehensive credit and customer service policies for U.S. operating units serving Cardmembers on active military duty and victims of natural disasters.
- Developed and led customized service training programs for U.S. operations staff.
- Redesigned card replacement process based on cost benefit analysis which resulted in improved customer satisfaction and lower costs.

New York City Human Resources Administration, New York, NY, February 1983 - October 1989

Director at Child Welfare Administration, Office of Family Services, Special Services for Adults

Responsibilities: Provided management leadership for services and programs.

- Coordinated external reporting to all city and state offices, including the semi-annual New York City Mayor's Management Report.
- Developed state mandated reporting and training curriculum for contracted foster care agencies in New York City.
- On-time implementation of corrective action plan focused on operations and information systems for adult homeless shelters.
- Supervised an operating unit with 90 staff and two administrative units.

## Education

University of Pennsylvania, Master of Social Work. Recipient of National Institute of Mental Health Merit Scholarship. Coursework taken at Wharton.

Brooklyn College, CUNY, Bachelor of Science. Honors: Magna Cum Laude; Dean's List

## Volunteer Activities/Professional Affiliations

Parent Teacher Student Organization, Westfield, N.J.

University of Pennsylvania Alumni Club of Metro NJ

Gerontology Advisory Council, Rutgers University School of Social Work

Newark Workforce Investment Board

Bergen Workforce Investment Board

## Licenses

Licensed Social Worker (L.S.W.), State of New Jersey



# DRAFT

THIS AGREEMENT made this        day of    2014, by and between:

THE COUNTY OF PASSAIC a body corporate and politic of the State of New Jersey, having its principal offices located at 401 Grand Street in the City of Paterson, County of Passaic and State of New Jersey (hereinafter sometimes referred to as the "COUNTY") . and

THE PASSAIC COUNTY HISTORICAL SOCIETY, a duly incorporated historical society organized under the laws of the State of New Jersey, having principal offices located at the Lambert Castle, Valley Road in the city of Paterson, County of Passaic, State of New Jersey (hereinafter sometimes referred to as the "SOCIETY")

## WITNESSETH:

WHEREAS    the Passaic County Historical Society has served the public of Passaic County since its organization in 1926; and

WHEREAS    the Passaic County Historical Society has maintained a museum at Lambert Castle for the benefit of the public since October, 1934; and

WHEREAS    the County of Passaic is authorized by N.J.S.A.40A:12-15 to lease real property to a duly incorporated historical society; and

WHEREAS    the Board of Chosen Freeholders of the County of Passaic, (herinafter. Referred to as the FREEHOLDERS) its unanimous adoption of a resolution dated        has authorized the granting of the within lease.

NOW THEREFORE in consideration of the sum of one dollar (\$1.00) and the mutual promises contained herein, the parties agree as follows:

1. The COUNTY grants the SOCIETY the right to continue to occupy and use for the public benefit the premises known as Lambert Castle located within a county park in the City of Paterson, County of Passaic and State of New Jersey for a period of twenty (25) years commencing on , 2014 and ending. 2039, except for that space on the second floor presently occupied by the Passaic County Historian and which is to be continued to be occupied by the current County Historian and his successors thereto;
2. In exchange for this lease, the SOCIETY shall maintain and operate within the Castle a museum and local history library for the benefit of the public. Any cessation of such operations shall result in the termination of this Agreement and the reversion of the premises to the full control of the COUNTY. It is understood and agreed that the Castle building and grounds may also be used for activities, including fund raising, which aid in the work of the SOCIETY or the preservation of Lambert Castle.
3. It is also understood that the SOCIETY shall permit the FREEHOLDERS of the County of Passaic the use of Lambert Castle for FREEHOLDER officially sponsored events, consistent with the SOCIETY's facility use policies, practices, and scheduled operation of the

facility and museum; and the SOCIETY shall waive its rental fees for these aforesaid purposes, with the understanding that the FREEHOLDERS will assume any supplemental or incidental expenses related to the use of the building in connection with aforementioned FREEHOLDER officially sponsored events. All requests for use of Lambert Castle by the FREEHOLDERS shall be made in advance of the event by the Passaic County Administrator to the SOCIETY'S Site Manager.

4. The SOCIETY shall supply a curator and such other staff as may be necessary to carry out its obligations under this Agreement.

5. The COUNTY shall be responsible for the inspection of the whole Castle structure and the making of any necessary repairs, and for the supply of heating, lighting, painting, general cleaning, garbage and waste disposal, rest rooms and police protection, if necessary. In connection with the responsibilities the COUNTY will continue to name the SOCIETY as an insured under its policies of general liability insurance.

6. Both parties recognize the historic significance of Lambert Castle and neither party will take any action, which will compromise the historic integrity of the building and grounds.

The SOCIETY will make no major structural changes to the Castle without the express approval of the COUNTY and any other necessary governing agencies. The SOCIETY will cooperate with the COUNTY in any of the

COUNTY's restoration and renovations of Lambert Castle.

7. This lease and agreement is made pursuant to the powers granted to the COUNTY by N.J.S.A. 40A: 12:15 and the resolution of the FREEHOLDERS, dated \_\_\_\_\_, the terms of which are incorporated herein and made a part hereof.

8.

IN WITNESS WHEREOF the parties have hereunto set their hands and seals or caused these presents to be signed by their appropriate officers duly authorized thereunto and their seals be affixed as of the day and year first written above.

ATTEST: PASSAIC COUNTY HISTORICAL SOCIETY

BY: \_\_\_\_\_  
President, Passaic County Historical Society

ATTEST: COUNTY OF PASSAIC

BY \_\_\_\_\_  
Director, Board of Chosen Freeholders

The Foregoing Agreement (Authorizing Resolution R- \_\_\_\_\_, Adopted on \_\_\_\_\_ Has Been Reviewed & Approved As To Form.

Passaic County Counsel By:

---

Deputy County Counsel

---

County Counsel



PASSAIC COUNTY HISTORICAL SOCIETY  
 Lambert Castle Museum • 3 Valley Road • Paterson, NJ 07503  
 (973) 247-0085 • [info@lambertcastle.org](mailto:info@lambertcastle.org)

## Facility Rental Policy

### Lambert Castle Museum and Grounds

Contents	Page
1. General Information	2
1.1. Description of Facilities	2
1.2. General Rental Conditions	3
1.3. Use Policy	3
1.4. Facility Accommodations	4
1.5. Application Procedure	4
1.6. Damage and Security Deposit	5
2. Rental Fee	5
2.1. Rental Rates	6
2.2. Rental Details	7
2.3. Staffing Requirements	7
3. Obligations of the Renter	8
3.1. Liability	8
3.2. Restrictions	9
3.3. Renter Responsibilities	10



## PASSAIC COUNTY HISTORICAL SOCIETY

Lambert Castle Museum • 3 Valley Road • Paterson, NJ 07503  
 (973) 247-0085 • [info@lambertcastle.org](mailto:info@lambertcastle.org)

Today, the Castle's modern facilities include upgraded/modern electrical, plumbing, heating, cooling and fire suppression/alarm systems. An elevator and handicapped-accessible bathrooms are also available

### 1.2. General Rental Conditions

The Passaic County Historical Society has the responsibility for proper stewardship of this historic property. Private use of the Castle and its grounds (Green, Esplanade and Terrace), or collectively referred to within as the Castle, is a privilege granted by the Historical Society. The decision to grant this privilege is at the sole discretion of the Passaic County Historical Society, which is the final authority on the ability to grant and deny applications for use, and the form within said use is taken.

Preserving the primary mission of the Society, to maintain a museum open to the public, all rental events must be scheduled outside of normal operation of the facility and the Museum. All events must begin or end at least an hour prior to the museum's operating hours. No event which may detract from the public image of the Passaic County Historical Society, or which may place the property or the Society's collections at risk, will be allowed.

Given the historic nature of the building, and the primary use of the building as a museum for historic objects, only finger-food may be served at interior events. No food heating devices will be permitted in the Castle. The kitchen facilities at the Castle are for serving only, and therefore, no heating or cooking can be done inside the Castle. Arrangements will be made prior to the event, with a member of staff, to determine the designated areas where food and beverages may be served and consumed. (All food choices must be reviewed and approved by the staff of the museum prior to the event). There are no restrictions to the service and consumption of food and non-alcoholic beverages on the Castle Green or other outdoor area.

### 1.3 Use Policy for Lambert Castle Museum and Grounds

1. The Castle may be used for ceremonies, lectures, meetings and exhibits. Other social events will be evaluated on a case by case basis.
2. Receptions may be held on the Castle Green, with access to the serving kitchen and restrooms, located on the first floor.



## PASSAIC COUNTY HISTORICAL SOCIETY

Lambert Castle Museum • 3 Valley Road • Paterson, NJ 07503  
 (973) 247-0085 • [info@lambertcastle.org](mailto:info@lambertcastle.org)

- a. The completed application form should be submitted to Castle staff at least 60 days in advance.
  - b. Applications are subject to the approval of the Passaic County Historical Society Board of Trustees
2. *Damage and Security Deposit* must be submitted with the application (see section 1.6).
  3. *A written confirmation letter* will be sent to the renter following receipt and approval of the completed application form and deposit. If the application is not approved, the deposit will be returned to the applicant.

### 1.6. **Damage and Security Deposit**

1. *Deposit Amount:* A deposit of \$1000 is required with all rentals for \$400 or more. For the rentals less than \$400, the security deposit will be \$500.
2. *Cancellations:* Once the application is approved and confirmed, fifty percent (50%) of the deposit will be withheld if the rental is cancelled by the renter. In the event that the Castle facilities are unavailable due to an unforeseen event or act of nature, the full deposit will be returned to the renter.
3. *Refund of Deposit:* The deposit is fully refundable after the event, provided no additional clean-up is required by Castle staff, and the contracted number of hours for the event is not exceeded. Damages to the building and/or contents will be covered under the renter's liability insurance determined in section 3.1.

## 2. Rental Fee

1. *Amount:* the exact rental fee for an event is established after the Client has fully described the event, expected attendance and specific requirements.
2. *When due:* The entire rental fee is due with the specified insurance and any additional certificates no later than fourteen (14) calendar days prior to the date of the event. The deposit is not included in the total rental fee. Failure to submit payment at that time will void the rental contracts and result in forfeiture of 50% of the deposit.





PASSAIC COUNTY HISTORICAL SOCIETY

Lambert Castle Museum • 3 Valley Road • Paterson, NJ 07503  
 (973) 247-0085 • [info@lambertcastle.org](mailto:info@lambertcastle.org)

together				100 chairs/tables
----------	--	--	--	-------------------

**2.2. Rental Details**

1. Events may last up to five (5) hours, including set-up and breakdown/ clean-up time. If the event extends beyond five hours, a charge of two hundred dollars (\$200.00) per each additional one half hours, or any portion thereof, will be charged. If the event is outdoors and requires the setting-up/ taking down of a tent, this extra item would not be charged. Equipment, tents, chairs, tables, etc. cannot be stored in or outside the Castle before or after a scheduled event.
2. Maximum interior use of the Castle is limited to 125 people, including staff, (see chart on page 5) and for outdoor events, use is limited to 200 people. In all cases, the occupancy limits are egress requirements contained in the State of New Jersey’s Fire Prevention Code shall be met.
3. Rental of the Castle is only for the facility and does not include chairs, tables, linens, china/flatware, etc. Arrangements for these items would be the responsibility of the renter. Rental of the Castle does provide automobile parking (limited to 90 spaces), electrical power, use of restrooms, use of the serving kitchen, and air-conditioning inside the Castle.

**2.3. Staffing Requirements and Fees**

1. *Staff Required:* Museum staff must be present during any facility rental or related facility use, i.e., rehearsals; and the Society reserves the right to determine the number of staff required.
2. *Staff Responsibilities:* Staff members are in attendance to protect the premises and handle building operations. They will not supervise or physically assist the renter, event or service vendors; maintain order, or set-up, remove or transport personal or event equipment and supplies.
3. *Fees:* Personnel charges are based on a flat hourly rate of \$25 per staff person.
4. *Technical Staff:* It is the renter’s responsibility to provide and operate technical



PASSAIC COUNTY HISTORICAL SOCIETY

Lambert Castle Museum • 3 Valley Road • Paterson, NJ 07503  
 (973) 247-0085 • [info@lambertcastle.org](mailto:info@lambertcastle.org)

5. *Left Items:* PCHS cannot assume any responsibility for items left by the caterer, guests, or renter. Renter or caterer is responsible for removing all articles brought in during the rental event.

**3.2. Restrictions**

1. Food and Beverages: See section 1.2.
2. NO SMOKING is permitted inside or outside the Castle. In addition, no candles, luminaries, sky lanterns, or any other flaming devices are allowed inside the Castle.
3. Helium and air balloons, sparklers and glitter, are specifically prohibited from the museum and grounds.
4. Illegal Substances: Use of illegal substance is prohibited at all times.
5. No abusive language, aggressive behavior, or intoxication will be tolerated. If someone is displaying disruptive behavior they will be required to leave the Castle and grounds by renter and/or security staff.
6. No live animals, with the exception of special needs service dogs, are permitted inside the Castle.
7. Nothing is to be thrown inside the building, for example confetti, rice, birdseed, rose petals, bubbles, etc.
8. Restricted amplified music (live or recorded) is allowed inside Lambert Castle Museum. Use of the Castle's piano may be obtained for a fee. See section 2.1. Vocalists may be amplified. Outside on the Green, amplified live or recorded music is allowed at moderate sound levels.
9. Dancing inside the museum must be limited to the atrium.
10. Equipment: Special or rental equipment for the event must be approved through a member of PCHS staff at least 14 days before the event. Smoke and fog machines and any type of dry ice dispenser are not permitted inside the museum.



## PASSAIC COUNTY HISTORICAL SOCIETY

Lambert Castle Museum • 3 Valley Road • Paterson, NJ 07503

(973) 247-0085 • [info@lambertcastle.org](mailto:info@lambertcastle.org)

5. The renter or caterer is responsible for providing protective materials for the bar set-up in order to prevent water from dripping on the furniture or floor and for protecting all furniture and mantels from watermarks or other damage.
6. The renter or caterer is responsible for backing any material that may come into contact with a wall with matting that will protect the wall surface from harm.
7. The renter or caterer is responsible for keeping floors clean where food is served and removing empty glasses, plates, etc. during the event and after the event.
8. The renter or caterer is responsible for all clean-up after the event, including removal of all trash, decorations, and other items brought into the Castle or onto the Castle grounds. All trash shall be bagged and removed to the approved garbage pick-up site.
9. Floors must be dust mopped. The serving kitchen sink, counters and equipment shall be wiped clean and the serving kitchen floor wet mopped.
10. The renter or caterer is responsible for inspecting the building and/or grounds around the event with the designated PCHS representative to ensure that the property is free of trash and all required clean-up has been completed.
11. In the case of a tent being erected outdoors on the Castle grounds, it is the responsibility of the renter to obtain a permit from the local fire official (Paterson Fire Department) for all tents in excess of 900 square feet in area, prior to the event. In addition, it shall be the responsibility of the renter or the tent provider to refill with soil any holes in the ground resulting from tent posts, pegs, etc.
12. Generators shall not be used within 20 feet of the Castle or any tent.
13. The renter must not, in his/her use of the Castle and/or Grounds, including any advertising of the event be held in the facility, discriminate on the basis of race, religion, ancestry, national origin, gender, sexual orientation, or mental or physical disability.
14. Organizations sponsoring events at the Castle or grounds shall not indicate or infer endorsement, sponsorship or affiliation by PCHS and may not use the name of the Society or Lambert Castle other than to indicate location. Organizations

# Passaic County Board of Chosen Freeholders

OFFICE OF THE  
PASSAIC COUNTY FREEHOLDERS

Director Pasquale "Pat" Lepore  
Deputy Director Theodore O. Best, Jr.  
John W. Bartlett  
Ronda Casson Cotroneo  
Terry Duffy  
Bruce James  
Hector C. Lora

401 Grand Street  
Paterson, New Jersey 07505

Tel: 973-881-4402  
Fax: 973-742-3746

Anthony J. De Nova III

Administrator

William J. Pascrell, III, Esq.

County Counsel

Louis E. Imhof, III, RMC

Clerk Of The Board



## Public Meeting (Board Meeting)

Date: Mar 25, 2014 - 5:30 PM

Location: County Administration  
220  
401 Grand Street  
Paterson, NJ 07505

Agenda: RESOLUTION AUTHORIZING THE COUNTY OF PASSAIC TO RE-ENTER INTO A LEASE AGREEMENT WITH THE PASSAIC COUNTY HISTORICAL SOCIETY FOR THE LATTER'S OCCUPANCY OF COUNTY PREMISES LOCATED IN LAMBERT CASTLE, ALL AS NOTED IN THE RESOLUTION

THIS RESOLUTION WAS REQUESTED BY:

REVIEWED BY:

Anthony J. De Nova III  
COUNTY ADMINISTRATOR

APPROVED AS TO FORM AND LEGALITY:

William J. Pascrell, III, Esq.  
COUNTY COUNSEL

Human Services

COMMITTEE NAME

Official Resolution#		R20140216					
Meeting Date		03/25/2014					
Introduced Date		03/25/2014					
Adopted Date		03/25/2014					
Agenda Item		I-17					
CAF #							
Purchase Req. #							
Result		Adopted					
FREEHOLDER	PRES.	ABS.	MOVE	SEC	AYE	NAY	ABST.
Lepore	✓				✓		
Best Jr	✓		✓		✓		
Bartlett	✓			✓	✓		
Cotroneo	✓				✓		
Duffy	✓				✓		
James	✓				✓		
Lora	✓				✓		

PRES.= present ABS.= absent  
MOVE= moved SEC= seconded  
AYE= yes NAY= no ABST.= abstain

Dated: March 26, 2014

**RESOLUTION AUTHORIZING THE COUNTY OF PASSAIC TO RE-ENTER INTO A LEASE AGREEMENT WITH THE PASSAIC COUNTY HISTORICAL SOCIETY FOR THE LATTER'S OCCUPANCY OF COUNTY PREMISES LOCATED IN LAMBERT CASTLE**

**WHEREAS** the Passaic County Historical Society has served the public of Passaic County since its organization in 1926; and

**WHEREAS** the Passaic County Historical Society has maintained a museum at Lambert Castle for the benefit of the public since October, 1034; and

**WHEREAS** the Board of Chosen Freeholders of the County of Passaic is desirous of re-entering into a lease agreement with the Passaic County Historical Society for the said society's use of the Lambert Castle for a period of twenty five (25) years commencing March 26, 2014 and ending March 25, 2039 thus superceding the current lease at issue; and

**WHEREAS** this matter was reviewed and approved by the Human Services Committee;

**NOW THEREFORE BE IT RESOLVED** that the Board of Chosen Freeholders of the County of Passaic hereby authorizes the County to re-enter into a lease agreement with the Passaic County Historical Society for the said society's use of the Lambert Castle for a period of twenty five (25) years commencing March 26, 2014 and ending March 25, 2039 thus superceding the current lease at issue.

JDP:lc

Dated: March 25, 2014

# Passaic County Board of Chosen Freeholders

OFFICE OF THE  
PASSAIC COUNTY FREEHOLDERS

Director Pasquale "Pat" Lepore  
Deputy Director Theodore O. Best, Jr.  
John W. Bartlett  
Ronda Casson Cotroneo  
Terry Duffy  
Bruce James  
Hector C. Lora

401 Grand Street  
Paterson, New Jersey 07505

Tel: 973-881-4402  
Fax: 973-742-3746

Anthony J. De Nova III

Administrator

William J. Pascrell, III, Esq.

County Counsel

Louis E. Imhof, III, RMC

Clerk Of The Board



## Public Meeting (Board Meeting)

Date: Mar 25, 2014 - 5:30 PM

Location: County Administration  
220  
401 Grand Street  
Paterson, NJ 07505

Agenda: RESOLUTION AUTHORIZING RESOLUTION REQUEST TO SUBMIT AN APPLICATION FOR THE FOLLOWING AVAILABLE GRANT, "DOE WEATHERIZATION 2013" – GRANT LOAN AGREEMENT IN THE AMOUNT OF \$62,691.00. THIS GRANT AGREEMENT WILL ENABLE THE WEATHERIZATION TO LOW-INCOME FAMILIES AND INDIVIDUALS WHO ARE DEEMED ELIGIBLE. BY WEATHERIZING THE ELIGIBLE UNITS, THIS PROJECT WILL ENSURE ENERGY EFFICIENCY FUEL SAVINGS AND INCREASED COMFORT, ALL AS NOTED IN THE RESOLUTION

THIS RESOLUTION WAS REQUESTED BY:

REVIEWED BY:

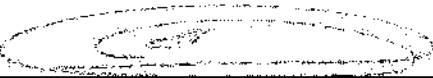
  
Anthony J. De Nova III  
COUNTY ADMINISTRATOR

APPROVED AS TO FORM AND LEGALITY:

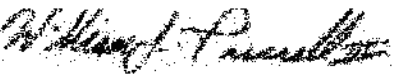
  
William J. Pascrell, III, Esq.  
COUNTY COUNSEL

Human Services  
COMMITTEE NAME

<b>Official Resolution#</b>	<b>R20140217</b>						
Meeting Date	03/25/2014						
Introduced Date	03/25/2014						
Adopted Date	03/25/2014						
Agenda Item	I-18						
CAF #							
Purchase Req. #							
Result	Adopted						
<b>FREEHOLDER</b>	<b>PRES.</b>	<b>ABS.</b>	<b>MOVE</b>	<b>SEC</b>	<b>AYE</b>	<b>NAY</b>	<b>ABST.</b>
Lepore	✓				✓		
Best Jr	✓		✓		✓		
Bartlett	✓			✓	✓		
Cotroneo	✓				✓		
Duffy	✓				✓		
James	✓				✓		
Lora	✓				✓		

PRES.= present ABS.= absent  
MOVE= moved SEC= seconded  
AYE= yes NAY= no ABST.= abstain

Dated: March 26, 2014

**RESOLUTION AUTHORIZING RESOLUTION REQUEST TO SUBMIT AN APPLICATION FOR THE FOLLOWING AVAILABLE GRANT, “DOE WEATHERIZATION 2013” – GRANT LOAN AGREEMENT IN THE AMOUNT OF \$62,691.00. THIS GRANT AGREEMENT WILL ENABLE THE WEATHERIZATION TO LOW-INCOME FAMILIES AND INDIVIDUALS WHO ARE DEEMED ELIGIBLE. BY WEATHERIZING THE ELIGIBLE UNITS, THIS PROJECT WILL ENSURE ENERGY EFFICIENCY FUEL SAVINGS AND INCREASED COMFORT**

**WHEREAS** the Passaic County Weatherization Division to reduce energy costs to low-income persons by improving the energy efficiency of their homes while ensuring their health and safety; and

**WHEREAS** the Director of Weatherization is desirous of requesting to submit an application for the following available grant “DOE Weatherization 2013” – Grant Loan Agreement in the amount of \$62,691.00; and

**WHEREAS** this Grant Agreement will enable the weatherization to low-income families and individuals who are deemed eligible; and

**WHEREAS** by weatherizing the eligible units, this project will ensure energy efficiency fuel savings and increased comfort; and

**WHEREAS** this matter was reviewed and approved by the Human Services Committee;

**NOW THEREFORE BE IT RESOLVED** that the Board of Chosen Freeholders of the County of Passaic hereby authorizes resolution to request to submit an application for the following available grant, “DOE Weatherization 2013” – Grant Loan Agreement in the amount of \$62,691.00. This Grant Agreement

will enable the weatherization to low-income families and individuals who are deemed eligible. By weatherizing the eligible units, this project will ensure energy efficiency fuel savings and increased comfort.

JDP:lc

Dated: March 25, 2014



COUNTY OF PASSAIC  
RESOLUTION REQUEST FORM

1. NAME OF REQUESTER & Tel # : Sam Yodice: 973-569-4710
2. DESCRIPTION OF RESOLUTION (PLEASE BE SPECIFIC AS POSSIBLE)

Resolution to request to submit an application for the following available grant ... "DOE Weatherization 2013" - Grant/Loan agreement in the amount of \$62,691.00 This grant agreement will enable the weatherization to low-income families and individuals who are deemed eligible. By weatherizing the eligible units, this project will ensure energy efficiency, fuel savings and increased comfort.

3. CERTIFICATION INFORMATION:

AMOUNT OF EXPENDITURE: \$ \_\_\_\_\_

BUDGET ACCOUNT #: \_\_\_\_\_  
\_\_\_\_\_

ATTACH A COPY OF A "DETAIL BUDGET ACCOUNT STATUS INCLUDING REQUISITION ITEMS" PAGE FROM EDMONDS

PLEASE NOTE THAT RESOLUTIONS FOR ALL CONTRACT AWARDS AND OTHER EXPENDITURES REQUIRE A CERTIFICATION OF FUNDS IN ORDER TO BE PLACED IN THE AGENDA. IT IS THE RESPONSIBILITY OF THE REQUESTING DEPARTMENT TO IDENTIFY THE APPLICABLE BUDGET LINE TO THE FINANCE DEPARTMENT. FAILURE TO DO SO WILL RESULT IN DELAYS IN PROCESSING THE RESOLUTION REQUEST.

4. COMMITTEE REVIEW: DATE

<input type="checkbox"/> Administration & Finance	_____
<input type="checkbox"/> Public Works / Buildings & Grounds	_____
<input type="checkbox"/> Planning & Economic Development	_____
<input checked="" type="checkbox"/> Health, Human Services & Community Affairs	3/13/2014
<input type="checkbox"/> Law & Public Safety	_____
<input type="checkbox"/> Energy	_____
<input type="checkbox"/> Other Specify: _____	_____

5. DISTRIBUTION LIST:

Administration  
 Finance  
 Counsel  
 Clerk to Board  
 Other(s) Specify: \_\_\_\_\_

# Passaic County Board of Chosen Freeholders

OFFICE OF THE  
PASSAIC COUNTY FREEHOLDERS

Director Pasquale "Pat" Lepore  
Deputy Director Theodore O. Best, Jr.  
John W. Bartlett  
Ronda Casson Cotroneo  
Terry Duffy  
Bruce James  
Hector C. Lora

401 Grand Street  
Paterson, New Jersey 07505

Tel: 973-881-4402  
Fax: 973-742-3746

Anthony J. De Nova III

Administrator

William J. Pascrell, III, Esq.

County Counsel

Louis E. Imhof, III, RMC

Clerk Of The Board



## Public Meeting (Board Meeting)

Date: Mar 25, 2014 - 5:30 PM

Location: County Administration  
220  
401 Grand Street  
Paterson, NJ 07505

Agenda: RESOLUTION AUTHORIZING THE AMENDMENT OF RESOLUTION R-14-0193 DATED MARCH 11, 2014 TO CORRECT THE YEAR OF TERM FROM 2017 TO 2016, ALL AS NOTED IN THE RESOLUTION

THIS RESOLUTION WAS REQUESTED BY:

REVIEWED BY:

Anthony J. De Nova III  
COUNTY ADMINISTRATOR

APPROVED AS TO FORM AND LEGALITY:

William J. Pascrell, III, Esq.  
COUNTY COUNSEL

Human Services

COMMITTEE NAME

Official Resolution#	R20140218						
Meeting Date	03/25/2014						
Introduced Date	03/25/2014						
Adopted Date	03/25/2014						
Agenda Item	I-19						
CAF #							
Purchase Req. #							
Result	Adopted						
FREEHOLDER	PRES.	ABS.	MOVE	SEC	AYE	NAY	ABST.
Lepore	✓				✓		
Best Jr	✓		✓		✓		
Bartlett	✓			✓	✓		
Cotroneo	✓				✓		
Duffy	✓				✓		
James	✓				✓		
Lora	✓				✓		

PRES.= present ABS.= absent  
MOVE= moved SEC= seconded  
AYE= yes NAY= no ABST.= abstain

Dated: March 26, 2014

**RESOLUTION AUTHORIZING THE AMENDMENT OF  
RESOLUTION R-14-0193 DATED MARCH 11, 2014 TO  
CORRECT THE YEAR OF TERM FROM 2017 TO 2016**

**WHEREAS** preserving open space and conserving natural resources ensure a sustainable quality of life in Passaic County;  
and

**WHEREAS** the Board of Chosen Freeholders of the County of Passaic is desirous of authorizing the amendment of Resolution R-14-0193, dated March 11, 2014. The purpose of this resolution is to correct the term/year of the appointment from 2017 to 2016.; and

**WHEREAS** this matter was reviewed and approved by the Human Services Committee;

**NOW THEREFORE BE IT RESOLVED** that the Board of Chosen Freeholders of the County of Passaic hereby authorizes the amendment of Resolution R-14-0193, dated March 11, 2014 to change the term/year of said appointment from 2017 to 2016.

JDP:lc

Dated: March 25, 2014

# Passaic County Board of Chosen Freeholders

OFFICE OF THE  
PASSAIC COUNTY FREEHOLDERS

Director Pasquale "Pat" Lepore  
Deputy Director Theodore G. Best, Jr.  
John W. Bartlett  
Ronda Casson Cotroneo  
Terry Duffy  
Bruce James  
Hector C. Lora

401 Grand Street  
Paterson, New Jersey 07505

Tel: 973-881-4402  
Fax: 973-742-3746

Anthony J. De Nova III  
*Administrator*

William J. Pascrell, III, Esq.  
*County Counsel*

Louis E. Imhof, III, RMC  
*Clerk Of The Board*



## Public Meeting (Board Meeting)

Date: Mar 11, 2014 - 5:30 PM

Location: County Administration Building  
220  
401 Grand Street  
Paterson, NJ 07505

Agenda: RESOLUTION AUTHORIZING THE RE-APPOINTMENTS OF JAMES ROGERS, SANDRA LAWSON AND BERNARD VROOM, III, TO THE OPEN SPACE AND FARMLAND PRESERVATION TRUST FUND COMMITTEE, ALL AS NOTED IN THE RESOLUTION

THIS RESOLUTION WAS REQUESTED BY:

REVIEWED BY:

Anthony J. De Nova III  
COUNTY ADMINISTRATOR

APPROVED AS TO FORM AND LEGALITY:

William J. Pascrell, III, Esq.  
COUNTY COUNSEL

Planning and Economic Development  
COMMITTEE NAME

Official Resolution#	R20140193						
Meeting Date	03/11/2014						
Introduced Date	03/11/2014						
Adopted Date	03/11/2014						
Agenda Item	I-32						
CAF #							
Purchase Req. #							
Result	Adopted						
FREEHOLDER	PRES.	ABS.	MOVE	SEC	AYE	NAY	ABST.
Lepore	✓				✓		
Best Jr	✓				✓		
Bartlett	✓			✓	✓		
Cotroneo	✓				✓		
Duffy	✓				✓		
James	✓		✓		✓		
Lora	✓				✓		

PRES.= present ABS.= absent  
MOVE= moved SEC= seconded  
AYE= yes NAY= no ABST.= abstain

Dated: March 13, 2014

Introduced on: March 25, 2014  
Adopted on: March 25, 2014  
Official Resolution#: R20140218

**RESOLUTION AUTHORIZING THE RE-APPOINTMENTS OF  
JAMES ROGERS, SANDRA LAWSON AND BERNARD VROOM,  
III, TO THE OPEN SPACE AND FARMLAND PRESERVATION  
TRUST FUND COMMITTEE**

**WHEREAS** the Board of Chosen Freeholders of the County of Passaic adopted a Resolution on the date of September 3, 1997 establishing an Advisory Committee relative to a previously adopted resolution, which authorizes the establishment of an "Open Space And Farmland Preservation Trust Fund" as a result of being voted upon by the voters of Passaic County and the Board wishes to make an appointment as set forth below; and

**WHEREAS** the Board is desirous of re-appointing Mr. James Rogers, Sandra Lawson and Bernard Vroom, III, for a three year term terminating December 31, 2016; and

**WHEREAS** this matter was reviewed and approved by the Finance & Administration Committee;

**NOW THEREFORE BE IT RESOLVED** that the Board of Chosen Freeholders hereby re-appoints James Rogers, Sandra Lawson and Bernard Vroom, III, for a three year term terminating December 31, 2017; and

**BE IT FURTHER RESOLVED** that the appointment shall take effect immediately as of this date accordingly.

JDP:lc

Dated: March 11, 2014

COUNTY OF PASSAIC  
RESOLUTION REQUEST FORM

1. NAME OF REQUESTER: Hector A. Herrera  
Telephone #: 973-881-4407

DESCRIPTION OF RESOLUTION: Reappointments to the Open Space Advisory Committee for three-year appointments ending December 31, 2016:

- 1. James Rogers
- 2. Sandra Lawson
- 3. Bernard Vroom, III

2. CERTIFICATION INFORMATION: N/A

ATTACH A COPY OF *THE REQUISITION FROM EDMUNDS*

PLEASE NOTE THAT RESOLUTIONS FOR ALL CONTRACT AWARDS AND OTHER EXPENDITURES REQUIRE A *REQUISITION*. RESOLUTION REQUESTS FOR EXPENDITURES WILL NOT BE CONSIDERED WITHOUT A REQUISITION NUMBER

3. AMOUNT OF EXPENDITURE: \$           N/A          

*REQUISITION #*           N/A          

4. COMMITTEE REVIEW:	<u>DATE</u>
<input checked="" type="checkbox"/> Administration & Finance	_____
<input type="checkbox"/> Public Works / Buildings & Grounds	_____
<input checked="" type="checkbox"/> Planning & Economic Development	_____
<input type="checkbox"/> Health, Human Services & Community Affairs	_____
<input type="checkbox"/> Law & Public Safety	_____
<input type="checkbox"/> Energy	_____
<input type="checkbox"/> Other Specify: _____	_____

5. DISTRIBUTION LIST:

- Administration
- Finance
- Counsel
- Clerk to the Board
- Procurement

Introduced on: March 11, 2014  
Adopted on: March 11, 2014  
Official Resolution#: R20140193  
Adopted on: March 11, 2014  
Official Resolution#: R20140218

# Passaic County Board of Chosen Freeholders

OFFICE OF THE  
PASSAIC COUNTY FREEHOLDERS

Director Pasquale "Pat" Lepore  
Deputy Director Theodore O. Best, Jr.  
John W. Bartlett  
Ronda Casson Cotroneo  
Terry Duffy  
Bruce James  
Hector C. Lora

401 Grand Street  
Paterson, New Jersey 07505

Tel: 973-881-4402  
Fax: 973-742-3746

Anthony J. De Nova III

Administrator

William J. Pascrell, III, Esq.

County Counsel

Louis E. Imhof, III, RMC

Clerk Of The Board



## Public Meeting (Board Meeting)

Date: Mar 25, 2014 - 5:30 PM

Location: County Administration  
220  
401 Grand Street  
Paterson, NJ 07505

Agenda: RESOLUTION FOR AWARD OF CONTRACT TO ZUCCARO, INC. FOR THE GOFFLE ROAD/ROCK ROAD/BRAEN AVENUE INTERSECTION IMPROVEMENT PROJECT IN THE BOROUGH OF HAWTHORNE, NJ AS PER BID, ALL AS NOTED IN THE RESOLUTION

THIS RESOLUTION WAS REQUESTED BY:

REVIEWED BY:

Anthony J. De Nova III  
COUNTY ADMINISTRATOR

APPROVED AS TO FORM AND LEGALITY:

William J. Pascrell, III, Esq.  
COUNTY COUNSEL

Public Works

COMMITTEE NAME

<b>Official Resolution#</b>	<b>R20140219</b>						
Meeting Date	03/25/2014						
Introduced Date	03/25/2014						
Adopted Date	03/25/2014						
Agenda Item	I-20						
CAF #	C-04-55-116-001-910						
Purchase Req. #	R4-02546						
Result	Adopted						
<b>FREEHOLDER</b>	<b>PRES.</b>	<b>ABS.</b>	<b>MOVE</b>	<b>SEC</b>	<b>AYE</b>	<b>NAY</b>	<b>ABST.</b>
Lepore	✓				✓		
Best Jr	✓		✓		✓		
Bartlett	✓			✓	✓		
Cotroneo	✓				✓		
Duffy	✓				✓		
James	✓				✓		
Lora	✓				✓		

PRES.= present ABS.= absent  
MOVE= moved SEC= seconded  
AYE= yes NAY= no ABST.= abstain

Dated: March 26, 2014

R20140219-2

**RESOLUTION FOR AWARD OF CONTRACT TO ZUCCARO, INC.  
FOR THE GOFFLE ROAD/ROCK ROAD/BRAEN AVENUE  
INTERSECTION IMPROVEMENT PROJECT IN THE BOROUGH  
OF HAWTHORNE, NJ AS PER BID**

**WHEREAS** bids for the Goffle Road/Rock Road/Braen Avenue Intersection Improvement Project in the Borough of Hawthorne, NJ were received on February 25, 2014; and

**WHEREAS** the bids were reviewed and tabulated by the Office of the Passaic County Engineer; and

**WHEREAS** Zuccaro, Inc. submitted a bid for the above-mentioned project and the County Engineer has recommended an award in the sum of \$384,214.50 as per the terms of the attached letter dated March 11, 2014 as the lowest responsible bidder; and

**WHEREAS** this matter was discussed by the members of the Public Works and Buildings & Grounds Committee at their meeting on March 10, 2014 and is being recommended to the full Board for approval; and

**WHEREAS** a certification is attached hereto to the effect that funds for the within contemplated expenditure are available; and

**NOW THEREFORE BE IT RESOLVED** by the Board of Chosen Freeholders of the County of Passaic that it hereby awards a contract for the Goffle Road/Rock Road/Braen Avenue Intersection Improvement Project in the Borough of Hawthorne, NJ to Zuccaro, Inc. in the amount of \$384,214.50; and

**BE IT FURTHER RESOLVED** that the Director, Clerk of the Board and County Counsel are authorized to execute all necessary documents on behalf of Passaic County.



Introduced on: March 25, 2014  
Adopted on: March 25, 2014  
Official Resolution#: R20140219

CERTIFICATION OF AVAILABLE FUNDS

THIS IS TO CERTIFY THAT FUNDS ARE AVAILABLE AS FOLLOWS:

AMOUNT: \$384,214.50

APPROPRIATION: C-04-55-116-001-910

PURPOSE: To award a contract to Zuccaro, Inc. for the Goffle Road/Rock Road/ Braen Avenue Intersection Improvement Project.

  
Michael Katz, County Treasurer

DATED: February 25, 2014

## COUNTY OF PASSAIC RESOLUTION REQUEST FORM

1. NAME OF REQUESTER & Tel # Engineering

DESCRIPTION OF RESOLUTION (PLEASE BE SPECIFIC AS POSSIBLE)  
Resolution Awarding a Contract to Zuccaro, Inc., in the amount of \$384,214.50, for the Goffle/Rock/Braen Intersection Improvements Project, Hawthorne.

CERTIFICATION INFORMATION:

ATTACH A COPY OF THE REQUISITION FROM EDMONDS

ATTACH A COPY OF A "DETAIL BUDGET ACCOUNT STATUS INCLUDING REQUISITION ITEMS" PAGE FROM EDMONDS

PLEASE NOTE THAT RESOLUTIONS FOR ALL CONTRACT AWARDS AND OTHER EXPENDITURES REQUIRE A REQUISITION. RESOLUTION REQUESTS FOR EXPENDITURES WILL NOT BE CONSIDERED WITHOUT A REQUISITION NUMBER

3. AMOUNT OF EXPENDITURE \$384,214.50  
BUDGET ACCOUNT: C-04-55-116-001-910

PURCHASE REQUISITION #

- | 4. COMMITTEE REVIEW:   | <u>DATE</u>    |
|--|----------------|
| <input type="checkbox"/> Administration & Finance                      | _____          |
| <input checked="" type="checkbox"/> Public Works / Buildings & Grounds | <u>3-10-14</u> |
| <input type="checkbox"/> Planning & Economic Development               | _____          |
| <input type="checkbox"/> Health, Human Services & Community Affairs    | _____          |
| <input type="checkbox"/> Law & Public Safety                           | _____          |
| <input type="checkbox"/> Energy  | _____          |
| <input type="checkbox"/> Other Specify: _____                          | _____          |

5. DISTRIBUTION LIST:
- Administration  
 Finance  
 Counsel  
 Clerk to Board  
 Procurement  
 Other(s) Specify \_\_\_\_\_

COUNTY OF PASSAIC  
 CO OF PASSAIC, ENGINEERING  
 (O) 973-881-4450  
 401 GRAND ST. ROOM 524  
 PATERSON, NJ 07505

REQUISITION	
NO.	R4-02546

SHIP TO	
VENDOR	VENDOR #: 11001 ZUCCARO, INC. 248 ALBERTA DRIVE SADDLE BROOK, NJ 07663

ORDER DATE: 03/19/14  
 DELIVERY DATE:  
 STATE CONTRACT:  
 F.O.B. TERMS:

QTY/UNIT	DESCRIPTION	ACCOUNT NO.	UNIT PRICE	TOTAL COST
1.00/EA	FOR ENCUMBRANCE PURPOSES ONLY FOR THE GOFFLE/ROCK/BRAEN INTERSECTION IMPROVEMENTS PROJECT AS PER RESOLUTION # DATED 3-25-2014 PARTIAL PAYMENTS	C-04-55-116-001-910	384,214.5000	384,214.50
			TOTAL	384,214.50

Introduced on: March 25, 2014  
 Adopted on: March 25, 2014  
 Official Resolution#: R20140219

REQUESTING DEPARTMENT \_\_\_\_\_ DATE \_\_\_\_\_



# County of Passaic

Administration Building  
401 Grand Street • Paterson, New Jersey 07505

OFFICE OF THE COUNTY ENGINEER  
ROOM 524

March 25, 2014  
March 25, 2014  
Commission#: R20140213  
St. J. Edmond, P.E.  
County Engineer

TEL: (973) 881-4456  
FAX: (973) 742-3936  
TDD: (973) 279-9786

March 11, 2014

Board of Chosen Freeholders  
Passaic County Administration Building  
401 Grand Street  
Paterson, New Jersey 07505

Re: Goffie Road/Rock Road/Braen Avenue Intersection Improvements,  
Borough of Hawthorne, New Jersey  
**Award of Contract**

Members of the Board:

The County of Passaic received bids for the Goffie Road/Rock Road/Braen Avenue Intersection Improvements project, Borough of Hawthorne, on February 25, 2014.

A total of 3 qualified bids were received with the following results (Bid Tabulations are attached):

Zuccaro, Inc.	Saddle Brook, NJ	\$ 384,214.50
J.C. Contracting, Inc	Bloomfield, NJ	\$ 389,642.50
Foggia Trinity Electric LLC.	Scotch Plains, NJ	\$ 441,626.00
(Zacarro's bid contained an addition error that did not change its rank)		
Engineer's Estimate		\$ 474,955.00

Based on the above analysis of the bids, I respectfully recommend that the Board of Chosen Freeholders enact a Resolution awarding a contract for the construction of **Goffie Road/Rock Road/Braen Avenue Intersection Improvements, Borough of Hawthorne**, to the lowest responsible bidder, **Zuccaro, Inc., 248 Alberta Drive, Saddle Brook, NJ 07663**, in the amount of **\$384,214.50** (Three hundred eighty-four thousand two hundred fourteen dollars and fifty cents). This Resolution should authorize the County Counsel to prepare the contracts and authorizing the Director of the Board of Chosen Freeholders, the Clerk of the Board, and the Director of Purchasing to sign and execute said contract on behalf of the Board and the County.

This bid was reviewed and recommended for Approval by the Public Works Committee at their meeting of March 10, 2014.

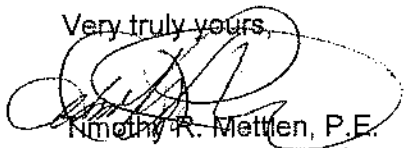
Very truly yours,  
  
Timothy R. Metten, P.E.  
Assistant County Engineer

Attachment

cc: Public Works Committee, Chair	County Council
County Administrator	Director of Purchasing
County Council	

Project: Goffle Road/Rock Road/Braen Avenue Intersection Improvements

C-014-003

Location: Borough of Hawthorne

County: Passaic/Bergen

Bids Received 2/25/2014

Prepared by: TRM

Date: 2/26/2014

**BID TABULATION**

**Engineer's Estimate**

**Zuccaro, Inc.**

**J.C. Contracting, Inc.**

ITEM #	DESCRIPTION	UNIT	QUANTITY	UNIT COST	AMOUNT	Bid Price	AMOUNT	Bid Price	AMOUNT
1	Construction Layout	L.S.	1	\$ 5,000.00	\$ 5,000.00	\$ 6,000.00	\$ 6,000.00	\$ 5,000.00	\$ 5,000.00
2	Construction Signs	S.F.	200	\$ 50.00	\$ 10,000.00	\$ 20.00	\$ 4,000.00	\$ 15.00	\$ 3,000.00
3	Drum	UNIT	25	\$ 75.00	\$ 1,875.00	\$ 25.00	\$ 625.00	\$ 10.00	\$ 250.00
4	Traffic Cone	UNIT	200	\$ 20.00	\$ 4,000.00	\$ 5.00	\$ 1,000.00	\$ 5.00	\$ 1,000.00
5	Allowance for Police Traffic Directors	Allow.	1	\$ 30,000.00	\$ 30,000.00	\$ 30,000.00	\$ 30,000.00	\$ 30,000.00	\$ 30,000.00
6	Clearing Site	L.S.	1	\$ 20,000.00	\$ 20,000.00	\$ 15,000.00	\$ 15,000.00	\$ 17,000.00	\$ 17,000.00
7	Roadway Excavation, Unclassified	C.Y.	180	\$ 30.00	\$ 5,400.00	\$ 28.00	\$ 5,040.00	\$ 40.00	\$ 7,200.00
8	Dense-Graded Aggregate Base Course, 6" Thick	S.Y.	175	\$ 25.00	\$ 4,375.00	\$ 22.00	\$ 3,850.00	\$ 14.00	\$ 2,450.00
9	HMA Milling, 3" or Less	S.Y.	3600	\$ 5.00	\$ 18,000.00	\$ 6.00	\$ 21,600.00	\$ 4.50	\$ 16,200.00
10	Hot Mix Asphalt 25H64 Base Course	TON	50	\$ 85.00	\$ 4,250.00	\$ 95.00	\$ 4,750.00	\$ 100.00	\$ 5,000.00
11	Hot Mix Asphalt 12.5H64 Intermediate Course	TON	25	\$ 85.00	\$ 2,125.00	\$ 95.00	\$ 2,375.00	\$ 110.00	\$ 2,750.00
12	Hot Mix Asphalt 9.5H64 Surface Course	TON	535	\$ 85.00	\$ 45,475.00	\$ 95.00	\$ 50,825.00	\$ 110.00	\$ 58,850.00
13	15" Reinforced Concrete Pipe, Class V	L.F.	80	\$ 100.00	\$ 8,000.00	\$ 85.00	\$ 6,800.00	\$ 100.00	\$ 8,000.00
14	Inlet, Type B	UNIT	1	\$ 3,500.00	\$ 3,500.00	\$ 2,400.00	\$ 2,400.00	\$ 2,500.00	\$ 2,500.00
15	Reset Existing Casting	Unit	8	\$ 325.00	\$ 2,600.00	\$ 250.00	\$ 2,000.00	\$ 350.00	\$ 2,800.00
16	Bicycle Safe Grate	Unit	4	\$ 325.00	\$ 1,300.00	\$ 300.00	\$ 1,200.00	\$ 300.00	\$ 1,200.00
17	Curb Piece	Unit	4	\$ 325.00	\$ 1,300.00	\$ 300.00	\$ 1,200.00	\$ 300.00	\$ 1,200.00
18	Concrete Sidewalk, 4" Thick	S.Y.	150	\$ 50.00	\$ 7,500.00	\$ 62.00	\$ 9,300.00	\$ 58.00	\$ 8,700.00
19	Concrete Sidewalk, Reinforced, 6" Thick	S.Y.	115	\$ 65.00	\$ 7,475.00	\$ 65.00	\$ 7,475.00	\$ 68.00	\$ 7,820.00
20	Hot Mix Asphalt Driveway, 6" Thick	S.Y.	55	\$ 65.00	\$ 3,575.00	\$ 32.00	\$ 1,760.00	\$ 40.00	\$ 2,200.00

Introduced on: March 23, 2014  
 Adopted on: March 25, 2014  
 Official Resolution: R2014-024

## BID TABULATION

## Engineer's Estimate

## Zuccaro, Inc.

## J.C. Contracting, Inc.

ITEM #	DESCRIPTION	UNIT	QUANTITY	UNIT COST	AMOUNT	Bid Price	AMOUNT	Bid Price	AMOUNT
21	Concrete Driveway, 6" Thick	S.Y.	25	\$ 65.00	\$ 1,625.00	\$ 66.00	\$ 1,650.00	\$ 68.00	\$ 1,700.00
22	Detectable Warning Surface	S.Y.	8.1	\$ 350.00	\$ 2,835.00	\$ 175.00	\$ 1,417.50	\$ 250.00	\$ 2,025.00
23	9" x 18" Concrete Vertical Curb	L.F.	800	\$ 30.00	\$ 24,000.00	\$ 19.00	\$ 15,200.00	\$ 26.00	\$ 20,800.00
24	Traffic Stripes, Long-Life, Epoxy Resin 4"	L.F.	2020	\$ 1.00	\$ 2,020.00	\$ 0.85	\$ 1,717.00	\$ 1.00	\$ 2,020.00
25	Traffic Stripes, Long-Life, Epoxy Resin 6"	L.F.	700	\$ 2.00	\$ 1,400.00	\$ 1.20	\$ 840.00	\$ 1.25	\$ 875.00
26	Traffic Markings, Thermoplastic	S.F.	1150	\$ 5.00	\$ 5,750.00	\$ 4.00	\$ 4,600.00	\$ 4.00	\$ 4,600.00
27	Regulatory and Warning Sign	S.F.	195.00	\$ 55.00	\$ 10,725.00	\$ 42.00	\$ 8,190.00	\$ 45.00	\$ 8,775.00
28	1 1/2" Rigid Nonmetallic Conduit	L.F.	50	\$ 35.00	\$ 1,750.00	\$ 35.00	\$ 1,750.00	\$ 30.00	\$ 1,500.00
29	2" Rigid Metallic Conduit	L.F.	85	\$ 35.00	\$ 2,975.00	\$ 36.00	\$ 3,060.00	\$ 30.00	\$ 2,550.00
30	3" Rigid Metallic Conduit	L.F.	525	\$ 55.00	\$ 28,875.00	\$ 48.00	\$ 25,200.00	\$ 30.00	\$ 15,750.00
31	18" X 36" Junction Box	UNIT	7	\$ 2,000.00	\$ 14,000.00	\$ 1,500.00	\$ 10,500.00	\$ 2,200.00	\$ 15,400.00
32	Foundation, Type SFT	UNIT	4	\$ 1,500.00	\$ 6,000.00	\$ 2,000.00	\$ 8,000.00	\$ 2,200.00	\$ 8,800.00
33	Foundation, Type P-MC	UNIT	1	\$ 3,000.00	\$ 3,000.00	\$ 2,200.00	\$ 2,200.00	\$ 2,500.00	\$ 2,500.00
34	Foundation, Type SFK	UNIT	2	\$ 1,000.00	\$ 2,000.00	\$ 2,000.00	\$ 4,000.00	\$ 2,400.00	\$ 4,800.00
35	Meter Cabinet, Type T	UNIT	1	\$ 3,000.00	\$ 3,000.00	\$ 1,850.00	\$ 1,850.00	\$ 1,900.00	\$ 1,900.00
36	Service Wire, No. 6 AWG	L.F.	100	\$ 5.00	\$ 500.00	\$ 2.00	\$ 200.00	\$ 2.00	\$ 200.00
37	Ground Wire, No. 8 AWG	L.F.	600	\$ 4.00	\$ 2,400.00	\$ 2.00	\$ 1,200.00	\$ 2.00	\$ 1,200.00
38	Controller, 8 Phase w/ Battery Backup System	UNIT	1	\$ 45,000.00	\$ 45,000.00	\$ 25,000.00	\$ 25,000.00	\$ 25,000.00	\$ 25,000.00
39	Traffic Signal Standard, Aluminum	UNIT	6	\$ 3,000.00	\$ 18,000.00	\$ 1,800.00	\$ 10,800.00	\$ 1,900.00	\$ 11,400.00
40	Traffic Signal Mast Arm, Aluminum	UNIT	6	\$ 2,500.00	\$ 15,000.00	\$ 2,000.00	\$ 12,000.00	\$ 2,000.00	\$ 12,000.00
41	Traffic Signal Cable, 2 Conductor	L.F.	250	\$ 5.00	\$ 1,250.00	\$ 3.00	\$ 750.00	\$ 2.75	\$ 687.50
42	Traffic Signal Cable, 5 Conductor	L.F.	730	\$ 5.00	\$ 3,650.00	\$ 3.00	\$ 2,190.00	\$ 3.00	\$ 2,190.00
43	Traffic Signal Cable, 10 Conductor	L.F.	1400	\$ 10.00	\$ 14,000.00	\$ 4.00	\$ 5,600.00	\$ 3.50	\$ 4,900.00
44	Traffic Signal Head	UNIT	11	\$ 1,250.00	\$ 13,750.00	\$ 1,150.00	\$ 12,650.00	\$ 1,100.00	\$ 12,100.00

Introduced on:  
Adopted on:  
Official Resolution

March 25, 2014  
March 25, 2014  
17-0319

**BID TABULATION**

**Engineer's Estimate**

**Zuccaro, Inc.**

**J.C. Contracting, Inc.**

ITEM #	DESCRIPTION	UNIT	QUANTITY	UNIT COST	AMOUNT	Bid Price	AMOUNT	Bid Price	AMOUNT	
45	Pedestrian Signal Head	UNIT	6	\$ 1,000.00	\$ 6,000.00	\$ 950.00	\$ 5,700.00	\$ 900.00	\$ 5,400.00	
46	Accessible Pedestrian Push Button Station	UNIT	2	\$ 1,250.00	\$ 2,500.00	\$ 675.00	\$ 1,350.00	\$ 700.00	\$ 1,400.00	
47	Image Defector	UNIT	3	\$ 7,500.00	\$ 22,500.00	\$ 4,700.00	\$ 14,100.00	\$ 5,000.00	\$ 15,000.00	
48	Controller Turn-On	UNIT	1	\$ 3,500.00	\$ 3,500.00	\$ 2,200.00	\$ 2,200.00	\$ 2,200.00	\$ 2,200.00	
49	APS Central Control Unit	UNIT	1	\$ 6,500.00	\$ 6,500.00	\$ 3,700.00	\$ 3,700.00	\$ 3,700.00	\$ 3,700.00	
50	Tree Removal, over 12" to 18" Diameter	UNIT	3	\$ 500.00	\$ 1,500.00	\$ 500.00	\$ 1,500.00	\$ 750.00	\$ 2,250.00	
51	Top Soiling, 4" Thick	S.Y.	700	\$ 4.00	\$ 2,800.00	\$ 10.00	\$ 7,000.00	\$ 5.00	\$ 3,500.00	
52	Fertilizing and Seeding, Type A-3	S.Y.	700	\$ 1.00	\$ 700.00	\$ 1.00	\$ 700.00	\$ 1.00	\$ 700.00	
53	Straw Mulching	S.Y.	700	\$ 1.00	\$ 700.00	\$ 1.00	\$ 700.00	\$ 1.00	\$ 700.00	
54	Excavation, Test Pit	C.Y.	100	\$ 100.00	\$ 10,000.00	\$ 50.00	\$ 5,000.00	\$ 20.00	\$ 2,000.00	
55	Video Inspection of Pipe	L.F.	300	\$ 5.00	\$ 1,500.00	\$ 5.00	\$ 1,500.00	\$ 5.00	\$ 1,500.00	
56	Cleaning Existing Pipe, 12" Diameter	L.F.	300	\$ 25.00	\$ 7,500.00	\$ 10.00	\$ 3,000.00	\$ 15.00	\$ 4,500.00	
					<b>TOTAL</b>	<b>\$ 474,955.00</b>	<b>TOTAL</b>	<b>\$ 384,214.50</b>	<b>TOTAL</b>	<b>\$ 389,642.50</b>

Introduced on: March 25, 2014  
 Adopted on: March 25, 2014  
 Official Resolution#: R20140219



Project: Goffle Road/Rock Road/Braen Avenue Intersection Improvements

Location: Borough of Hawthorne

County: Passaic/Bergen

Prepared by: TRM

BID TABULATION

Foggia Trinity Electric, LLC Orchard Holdings

ITEM #	DESCRIPTION	UNIT	QUANTITY	Bid Price	AMOUNT	
1	Construction Layout	L.S.	1	\$ 9,011.00	\$ 9,011.00	R e j e c t e d  f o r  M i s s i n g  D
2	Construction Signs	S.F.	200	\$ 7.00	\$ 1,400.00	
3	Drum	UNIT	25	\$ 5.00	\$ 125.00	
4	Traffic Cone	UNIT	200	\$ 1.00	\$ 200.00	
5	Allowance for Police Traffic Directors	Allow.	1	\$ 30,000.00	\$ 30,000.00	
6	Clearing Site	L.S.	1	\$ 7,500.00	\$ 7,500.00	
7	Roadway Excavation, Unclassified	C.Y.	180	\$ 43.00	\$ 7,740.00	
8	Dense-Graded Aggregate Base Course, 6" Thick	S.Y.	175	\$ 12.00	\$ 2,100.00	
9	HMA Milling, 3" or Less	S.Y.	3600	\$ 7.25	\$ 26,100.00	
10	Hot Mix Asphalt 25H64 Base Course	TON	50	\$ 140.00	\$ 7,000.00	
11	Hot Mix Asphalt 12.5H64 Intermediate Course	TON	25	\$ 140.00	\$ 3,500.00	
12	Hot Mix Asphalt 9.5H64 Surface Course	TON	535	\$ 175.00	\$ 93,625.00	
13	15" Reinforced Concrete Pipe, Class V	L.F.	80	\$ 105.00	\$ 8,400.00	
14	Inlet, Type B	UNIT	1	\$ 3,500.00	\$ 3,500.00	
15	Reset Existing Casting	Unit	8	\$ 350.00	\$ 2,800.00	
16	Bicycle Safe Grate	Unit	4	\$ 350.00	\$ 1,400.00	
17	Curb Piece	Unit	4	\$ 350.00	\$ 1,400.00	
18	Concrete Sidewalk, 4" Thick	S.Y.	150	\$ 85.00	\$ 12,750.00	
19	Concrete Sidewalk, Reinforced, 6" Thick	S.Y.	115	\$ 92.00	\$ 10,580.00	
20	Hot Mix Asphalt Driveway, 6" Thick	S.Y.	55	\$ 35.00	\$ 1,925.00	

Introduced on: March 25, 2014  
 Adopted on: March 25, 2014  
 Official Resolution#: R20140219

BID TABULATION

Foggia Trinity Electric, LLC Orchard Holdings

ITEM #	DESCRIPTION	UNIT	QUANTITY	Bid Price	AMOUNT	
21	Concrete Driveway, 6" Thick	S.Y.	25	\$ 92.00	\$ 2,300.00	D c u m e n t s
22	Detectable Warning Surface	S.Y.	8.1	\$ 350.00	\$ 2,835.00	
23	9" x 18" Concrete Vertical Curb	L.F.	800	\$ 40.00	\$ 32,000.00	
24	Traffic Stripes, Long-Life, Epoxy Resin 4"	L.F.	2020	\$ 1.25	\$ 2,525.00	
25	Traffic Stripes, Long-Life, Epoxy Resin 6"	L.F.	700	\$ 1.75	\$ 1,225.00	
26	Traffic Markings, Thermoplastic	S.F.	1150	\$ 4.00	\$ 4,600.00	
27	Regulatory and Warning Sign	S.F.	195.00	\$ 47.00	\$ 9,165.00	
28	1 1/2" Rigid Nonmetallic Conduit	L.F.	50	\$ 18.00	\$ 900.00	
29	2" Rigid Metallic Conduit	L.F.	85	\$ 23.00	\$ 1,955.00	
30	3" Rigid Metallic Conduit	L.F.	525	\$ 35.00	\$ 18,375.00	
31	18" X 36" Junction Box	UNIT	7	\$ 1,650.00	\$ 11,550.00	
32	Foundation, Type SFT	UNIT	4	\$ 1,250.00	\$ 5,000.00	
33	Foundation, Type P-MC	UNIT	1	\$ 1,850.00	\$ 1,850.00	
34	Foundation, Type SFK	UNIT	2	\$ 1,350.00	\$ 2,700.00	
35	Meter Cabinet, Type T	UNIT	1	\$ 1,780.00	\$ 1,780.00	
36	Service Wire, No. 6 AWG	L.F.	100	\$ 3.01	\$ 301.00	
37	Ground Wire, No. 8 AWG	L.F.	600	\$ 2.65	\$ 1,590.00	
38	Controller, 8 Phase w/ Battery Backup System	UNIT	1	\$ 25,600.00	\$ 25,600.00	
39	Traffic Signal Standard, Aluminum	UNIT	6	\$ 1,550.00	\$ 9,300.00	
40	Traffic Signal Mast Arm, Aluminum	UNIT	6	\$ 1,410.00	\$ 8,460.00	
41	Traffic Signal Cable, 2 Conductor	L.F.	250	\$ 2.35	\$ 587.50	
42	Traffic Signal Cable, 5 Conductor	L.F.	730	\$ 2.75	\$ 2,007.50	
43	Traffic Signal Cable, 10 Conductor	L.F.	1400	\$ 3.41	\$ 4,774.00	
44	Traffic Signal Head	UNIT	11	\$ 970.00	\$ 10,670.00	

Introduced on: March 25, 2014  
 Adopted on: March 25, 2014  
 Official Resolution#: R20140219

BID TABULATION				Fofggia Trinity Electric, LLC	Orchard Holdings
ITEM #	DESCRIPTION	UNIT	QUANTITY	Bid Price	AMOUNT
45	Pedestrian Signal Head	UNIT	6	\$ 645.00	\$ 3,870.00
46	Accessible Pedestrian Push Button Station	UNIT	2	\$ 610.00	\$ 1,220.00
47	Image Detector	UNIT	3	\$ 6,570.00	\$ 19,710.00
48	Controller Turn-On	UNIT	1	\$ 1,695.00	\$ 1,695.00
49	APS Central Control Unit	UNIT	1	\$ 3,900.00	\$ 3,900.00
50	Tree Removal, over 12" to 18" Diameter	UNIT	3	\$ 1,500.00	\$ 4,500.00
51	Top Soiling, 4" Thick	S.Y.	700	\$ 9.00	\$ 6,300.00
52	Fertilizing and Seeding, Type A-3	S.Y.	700	\$ 1.00	\$ 700.00
53	Straw Mulching	S.Y.	700	\$ 1.00	\$ 700.00
54	Excavation, Test Pit	C.Y.	100	\$ 5.25	\$ 525.00
55	Video Inspection of Pipe	L.F.	300	\$ 9.00	\$ 2,700.00
56	Cleaning Existing Pipe, 12" Diameter	L.F.	300	\$ 9.00	\$ 2,700.00
				<b>TOTAL</b>	<b>\$ 441,626.00</b>

# Passaic County Board of Chosen Freeholders

OFFICE OF THE  
PASSAIC COUNTY FREEHOLDERS

Director Pasquale "Pat" Lepore  
Deputy Director Theodore O. Best, Jr.  
John W. Bartlett  
Ronda Casson Cotroneo  
Terry Duffy  
Bruce James  
Hector C. Lora

401 Grand Street  
Paterson, New Jersey 07505

Tel: 973-881-4402  
Fax: 973-742-3746

Anthony J. De Nova III

Administrator

William J. Pascrell, III, Esq.

County Counsel

Louis E. Imhof, III, RMC

Clerk Of The Board



## Public Meeting (Board Meeting)

Date: Mar 25, 2014 - 5:30 PM

Location: County Administration  
220  
401 Grand Street  
Paterson, NJ 07505

Agenda: RESOLUTION APPROVING PLANS AND SPECIFICATIONS AND AUTHORIZING THE ADVERTISEMENT AND RECEIPT OF BIDS FOR THE PROJECT KNOWN AS THE 2014 LOWER COUNTY ROAD RESURFACING PROJECT IN PATERSON, CLIFTON, PASSAIC, HALEDON AND HAWTHORNE, NEW JERSEY, ALL AS NOTED IN THE RESOLUTION

THIS RESOLUTION WAS REQUESTED BY:

REVIEWED BY:

Anthony J. De Nova III  
COUNTY ADMINISTRATOR

APPROVED AS TO FORM AND LEGALITY:

William J. Pascrell, III, Esq.  
COUNTY COUNSEL

Public Works

COMMITTEE NAME

Official Resolution#	R20140220						
Meeting Date	03/25/2014						
Introduced Date	03/25/2014						
Adopted Date	03/25/2014						
Agenda Item	I-21						
CAF #							
Purchase Req. #							
Result	Adopted						
FREEHOLDER	PRES.	ABS.	MOVE	SEC	AYE	NAY	ABST.
Lepore	✓				✓		
Best Jr	✓		✓		✓		
Bartlett	✓			✓	✓		
Cotroneo	✓				✓		
Duffy	✓				✓		
James	✓				✓		
Lora	✓				✓		

PRES.= present ABS.= absent  
MOVE= moved SEC= seconded  
AYE= yes NAY= no ABST.= abstain

Dated: March 26, 2014

Res. Pg: 1.21-2

**RESOLUTION APPROVING PLANS AND SPECIFICATIONS  
AND AUTHORIZING THE ADVERTISEMENT AND RECEIPT  
OF BIDS FOR THE PROJECT KNOWN AS THE 2014 LOWER  
COUNTY ROAD RESURFACING PROJECT IN PATERSON,  
CLIFTON, PASSAIC, HALEDON AND HAWTHORNE, NEW  
JERSEY**

**WHEREAS** the Passaic County Engineer's Office has received the Plans and Specifications for the Project known as the 2014 Lower County Road Resurfacing Project in Paterson, Clifton, Passaic, Haledon and Hawthorne, NJ; and

**WHEREAS** the Passaic County Engineer has reviewed the Plans and Specifications and finds them to be in conformance with Passaic County Engineering Standards; and

**WHEREAS** by letter dated March 11, 2014 Office of the Passaic County Engineer has recommended that the Board of Chosen Freeholders approve said Plans and Specifications and authorize the Director of Purchasing to receive bids; and

**WHEREAS** this matter has been reviewed by the Freeholder members of the Committee for Public Works & Buildings & Grounds at a meeting on March 10, 2014 who are recommending approval by the entire Board;

**NOW THEREFORE BE IT RESOLVED** by the Board of Chosen Freeholders of the County of Passaic that it hereby approves the Plans and Specifications for the aforementioned project and authorizes the Director of Purchasing to advertise and receive bids for this project.

March 25, 2014



# County of Passaic

Administration Building  
401 Grand Street • Paterson, New Jersey 07505

OFFICE OF THE COUNTY ENGINEER  
ROOM 524

Steven J. Edmond, P.E.  
County Engineer

TEL: (973) 881-4456  
FAX: (973) 742-3936  
TDD: (973) 279-9786

March 11, 2014

Board of Chosen Freeholders  
Passaic County Administration Building  
401 Grand Street  
Paterson, New Jersey 07505

Re: 2014 Road Resurfacing  
Lower County  
**APPROVAL OF PLANS & SPECIFICATIONS AND  
AUTHORIZATION TO BID**

Members of the Board:

The County's Consultant, Remington & Vernick Engineers of Haddonfield, NJ, has designed and prepared the proposed Construction Plans and Supplementary Specifications for the following 2014 Resurfacing contract:

- Lower County; including Paterson, Clifton, Passaic, Haledon and Hawthorne

My office has reviewed these Plans and Specifications and find them to be in conformance with Passaic County and other Engineering Standards.

The above-mentioned Projects were discussed and recommended for approval at the Public Works Committee and Buildings & Grounds Committee Meeting of March 10, 2014.

Therefore, I recommend that the Board of Chosen Freeholders ADOPT the necessary RESOLUTION, approving the Plans and Specifications, and authorize the Department of Procurement to advertise and receive bids for these Projects.

Very truly yours,

Timothy R. Mettlen, P.E.  
Assistant County Engineer

SJE/trm

cc: Chair, Public Works and Buildings & Grounds Committee  
County Administrator  
County Counsel  
Director of Finance  
Director of Purchasing

Introduced on: March 25, 2014  
Adopted on: March 25, 2014  
Official Resolution#: R20140220

# Passaic County Board of Chosen Freeholders

OFFICE OF THE  
PASSAIC COUNTY FREEHOLDERS

Director Pasquale "Pat" Lepore  
Deputy Director Theodore O. Best, Jr.  
John W. Bartlett  
Ronda Casson Cotroneo  
Terry Duffy  
Bruce James  
Hector C. Lora

401 Grand Street  
Paterson, New Jersey 07505

Tel: 973-881-4402  
Fax: 973-742-3746

Anthony J. De Nova III

Administrator

William J. Pascrell, III, Esq.

County Counsel

Louis E. Imhof, III, RMC

Clerk Of The Board



## Public Meeting (Board Meeting)

Date: Mar 25, 2014 - 5:30 PM

Location: County Administration  
220  
401 Grand Street  
Paterson, NJ 07505

Agenda: RESOLUTION APPROVING PLANS AND SPECIFICATIONS AND AUTHORIZING THE ADVERTISEMENT AND RECEIPT OF BIDS FOR THE PROJECT KNOWN AS THE 2014 UPPER COUNTY ROAD RESURFACING PROJECT IN BLOOMINGDALE, HALEDON, LITTLE FALLS, WANAQUE, WAYNE AND WEST MILFORD, NEW JERSEY, ALL AS NOTED IN THE RESOLUTION

THIS RESOLUTION WAS REQUESTED BY:

REVIEWED BY:

Anthony J. De Nova III  
COUNTY ADMINISTRATOR

APPROVED AS TO FORM AND LEGALITY:

William J. Pascrell, III, Esq.  
COUNTY COUNSEL

Public Works

COMMITTEE NAME

<b>Official Resolution#</b>		<b>R20140221</b>					
Meeting Date		03/25/2014					
Introduced Date		03/25/2014					
Adopted Date		03/25/2014					
Agenda Item		I-22					
CAF #							
Purchase Req. #							
Result		Adopted					
<b>FREEHOLDER</b>	<b>PRES.</b>	<b>ABS.</b>	<b>MOVE</b>	<b>SEC</b>	<b>AYE</b>	<b>NAY</b>	<b>ABST.</b>
Lepore	✓				✓		
Best Jr	✓		✓		✓		
Bartlett	✓			✓	✓		
Cotroneo	✓				✓		
Duffy	✓				✓		
James	✓				✓		
Lora	✓				✓		

PRES.= present ABS.= absent  
MOVE= moved SEC= seconded  
AYE= yes NAY= no ABST.= abstain

Dated: March 26, 2014

Res Pg: 1.22-2

**RESOLUTION APPROVING PLANS AND SPECIFICATIONS  
AND AUTHORIZING THE ADVERTISEMENT AND RECEIPT  
OF BIDS FOR THE PROJECT KNOWN AS THE 2014 UPPER  
COUNTY ROAD RESURFACING PROJECT IN  
BLOOMINGDALE, HALEDON, LITTLE FALLS, WANAQUE,  
WAYNE AND WEST MILFORD, NEW JERSEY**

**WHEREAS** the Passaic County Engineer's Office has received the Plans and Specifications for the Project known as the 2014 Upper County Road Resurfacing Project in Bloomingdale, Haledon, Little Falls, Wanaque, Wayne and West Milford, NJ; and

**WHEREAS** the Passaic County Engineer has reviewed the Plans and Specifications and finds them to be in conformance with Passaic County Engineering Standards; and

**WHEREAS** by letter dated March 11, 2014 Office of the Passaic County Engineer has recommended that the Board of Chosen Freeholders approve said Plans and Specifications and authorize the Director of Purchasing to receive bids; and

**WHEREAS** this matter has been reviewed by the Freeholder members of the Committee for Public Works & Buildings & Grounds at a meeting on March 10, 2014 who are recommending approval by the entire Board;

**NOW THEREFORE BE IT RESOLVED** by the Board of Chosen Freeholders of the County of Passaic that it hereby approves the Plans and Specifications for the aforementioned project and authorizes the Director of Purchasing to advertise and receive bids for this project.

March 25, 2014





# County of Passaic

Administration Building  
401 Grand Street • Paterson, New Jersey 07505

OFFICE OF THE COUNTY ENGINEER  
ROOM 524

Steven J. Edmond, P.E.  
County Engineer

TEL: (973) 881-4456  
FAX: (973) 742-3936  
TDD: (973) 279-9786

March 11, 2014

Board of Chosen Freeholders  
Passaic County Administration Building  
401 Grand Street  
Paterson, New Jersey 07505

Re: 2014 Road Resurfacing  
Upper County  
**APPROVAL OF PLANS & SPECIFICATIONS AND  
AUTHORIZATION TO BID**

Members of the Board:

The County's Consultant, Remington & Vernick Engineers of Haddonfield, NJ, has designed and prepared the proposed Construction Plans and Supplementary Specifications for the following 2014 Resurfacing contract:

- Upper County; Including Bloomingdale, Haledon, Little Falls, Wanaque, Wayne & West Milford

My office has reviewed these Plans and Specifications and find them to be in conformance with Passaic County and other Engineering Standards.

The above-mentioned Projects were discussed and recommended for approval at the Public Works Committee and Buildings & Grounds Committee Meeting of March 10, 2014.

Therefore, I recommend that the Board of Chosen Freeholders ADOPT the necessary RESOLUTION, approving the Plans and Specifications, and authorize the Department of Procurement to advertise and receive bids for these Projects.

Very truly yours,

Timothy R. Mettlen, P.E.  
Assistant County Engineer

SJE/trm

cc: Chair, Public Works and Buildings & Grounds Committee  
County Administrator  
County Counsel  
Director of Finance  
Director of Purchasing

Introduced on: March 25, 2014  
Adopted on: March 25, 2014  
Official Resolution#: R20140221

# Passaic County Board of Chosen Freeholders

OFFICE OF THE  
PASSAIC COUNTY FREEHOLDERS

Director Pasquale "Pat" Lepore  
Deputy Director Theodore O. Best, Jr.  
John W. Bartlett  
Ronda Casson Cotroneo  
Terry Duffy  
Bruce James  
Hector C. Lora

401 Grand Street  
Paterson, New Jersey 07505

Tel: 973-881-4402  
Fax: 973-742-3746

Anthony J. De Nova III

Administrator

William J. Pascrell, III, Esq.

County Counsel

Louis E. Imhof, III, RMC

Clerk Of The Board



## Public Meeting (Board Meeting)

Date: Mar 25, 2014 - 5:30 PM

Location: County Administration  
220  
401 Grand Street  
Paterson, NJ 07505

Agenda: RESOLUTION APPROVING ROAD OPENING PERMIT TO PSE&G FOR INSTALLATION OF MANHOLES AND DUCT BANK ON RATZER ROAD AT ROCK ROAD IN WAYNE, NJ, ALL AS NOTED IN THE RESOLUTION

THIS RESOLUTION WAS REQUESTED BY:

REVIEWED BY:

Anthony J. De Nova III  
COUNTY ADMINISTRATOR

APPROVED AS TO FORM AND LEGALITY:

William J. Pascrell, III, Esq.  
COUNTY COUNSEL

Public Works

COMMITTEE NAME

Official Resolution#		R20140222					
Meeting Date		03/25/2014					
Introduced Date		03/25/2014					
Adopted Date		03/25/2014					
Agenda Item		I-23					
CAF #							
Purchase Req. #							
Result		Adopted					
FREEHOLDER	PRES.	ABS.	MOVE	SEC	AYE	NAY	ABST.
Lepore	✓				✓		
Best Jr	✓		✓		✓		
Bartlett	✓			✓	✓		
Cotroneo	✓				✓		
Duffy	✓				✓		
James	✓				✓		
Lora	✓				✓		

PRES.= present ABS.= absent  
MOVE= moved SEC= seconded  
AYE= yes NAY= no ABST.= abstain

Dated: March 26, 2014

**RESOLUTION APPROVING ROAD OPENING PERMIT TO  
PSE&G FOR INSTALLATION OF MANHOLES AND DUCT BANK  
ON RATZER ROAD AT ROCK ROAD IN WAYNE, NJ**

**WHEREAS** the Supervisor of Passaic County Roads is in receipt of a request for a Road Opening Permit from the Public Service Electric & Gas Company, Mobile Construction Division, to open up a section of Ratzer Road at Rock Road in Wayne, New Jersey for a distance in excess of 1,000 linear feet to install manholes and duct bank for underground 69kv line; and

**WHEREAS** the Board of Chosen Freeholders adopted a resolution on the date of September 12, 1991 with respect to requirements concerning road opening permits relative to construction and reconstruction of County roadways; and

**WHEREAS** the Supervisor of Passaic County Roads has reviewed the aforesaid request and recommends that this Board grant permission to Public Service Electric & Gas Company to open said County road and to issue the necessary number of Road Opening Permits pursuant not only to the terms set forth above, but to the conditions set forth in the County Supervisor's letter dated March 11, 2014 (copy of said letter is attached hereto and made a part hereof); and

**WHEREAS** this application was discussed at the Public Works and Buildings & Grounds Committee meeting of March 10, 2014 and recommended to the full Board for approval;

**NOW THEREFORE BE IT RESOLVED** by the Board of Chosen Freeholders of the County of Passaic that it hereby grants

permission to Public Service Electric & Gas Company to open up sections of the above-stated County road in Wayne, New Jersey for a distance in excess of 1,000 linear feet to install manholes and duct bank for underground 69kv line pursuant to the terms and conditions set forth above, and subject to the payment of all road opening fees prior to the opening of said roadway and to the adherence to the pavement trench restoration requirements of Passaic County.

March 25, 2014



# County of Passaic

Administration Building Annex  
307 Pennsylvania Avenue • Paterson, New Jersey 07503

**Jack Nigro**  
Passaic County  
Supervisor of Roads

## OPERATIONS DIVISION

Tel: (973) 881-4500  
Fax: (973) 742-2498  
Cell: (973) 592-2168  
E-mail: jackn@passaiccountynj.org

March 11, 2014

Mr. Michael Glovin, Esq.  
Asst. Passaic County Counsel  
401 Grand Street  
Paterson, New Jersey 07505

Re: Resolution Request-PSE&G Co., Mobile Construction Division  
Ratzer Road, Wayne (at Rock Road)  
**Road Opening in Excess of 1000LF**  
**Road Resurfaced within five (5) years**

Dear Mr. Glovin:

At the March 11, 2014 meeting of the Public Works and Buildings & Grounds Committee a request was heard for Public Service Electric and Gas Co., Mobile Construction Division to open county roadway to install manholes and duct bank for underground 69kv line total linear footage of 2000lf on Ratzer Road at Rock Road in the Township of Wayne. This section of Ratzer Road was last resurfaced on September 1, 2010. The Committee directed that a resolution be made granting the request from Public Service Electric and Gas Co. on Ratzer Road at Rock Road in the Township of Wayne. A Copy of application for the Right-of-Way entry permit and bond computation form is enclosed. If you should have any question or I can be of additional assistance, please feel free to contact me.

Thank you for your attention and your assistance with this matter.

Very truly yours,

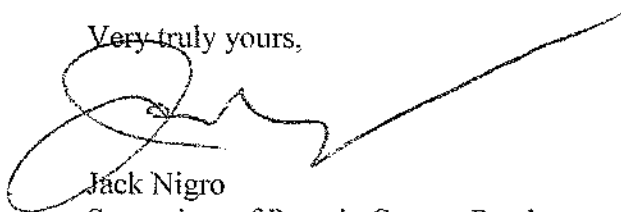
  
Jack Nigro  
Supervisor of Passaic County Roads

JN/gdj

Introduced on: March 25, 2014  
Adopted on: March 25, 2014  
Official Resolution#: R20140222

cc: Alexander Duffy, Chair, Public Works and Buildings & Grounds Committee  
Anthony DeNova, Passaic County Administrator  
Steven Edmond, P.E., Passaic County Engineer

COUNTY OF PASSAIC  
DEPARTMENT OF PUBLIC WORKS  
OPERATIONS DIVISION  
307 PENNSYLVANIA AVENUE  
PATERSON, NEW JERSEY 07503

Paterson-Hamburg Tpk  
8-3-2011  
Ratzer  
9-1-2010

OFFICE - (973) 881-4500 FAX - (973) 742-2498 INSPECTION - (973) 881-4503

Date 2/24/14

APPLICATION FOR RIGHT-OF-WAY ENTRY PERMIT

Name of Applicant/Contractor: PSEG (Mobile Construction Division)

Applicant's Address: 900 W Grand St  
Elizabeth, NJ 07202

Telephone Number: 908 558 7516 Emergency 24 Hour Number: 732 221 6041

Location of Work: Paterson - Hamburg Turnpike and Ratzer Rd

Municipality: Wayne

Purpose of Work: Install manholes and duct bank for ~~69kV~~ underground 69kV line

Total Linear Footage: 2000' Excavation Start Date: \_\_\_\_\_

\*\*\* If this project or trench work consists of 1,000 or more linear feet or if this is to be done on a roadway resurfaced within the past five (5) years, permission by the Passaic County Board of Chosen Freeholders will be required prior to the issuance of any permits.

**DRAW A SKETCH BELOW SHOWING THE LOCATION OF THE WORK**  
(SHOW NEAREST CROSS STREET, UTILITY POLE NUMBER, ETC.)

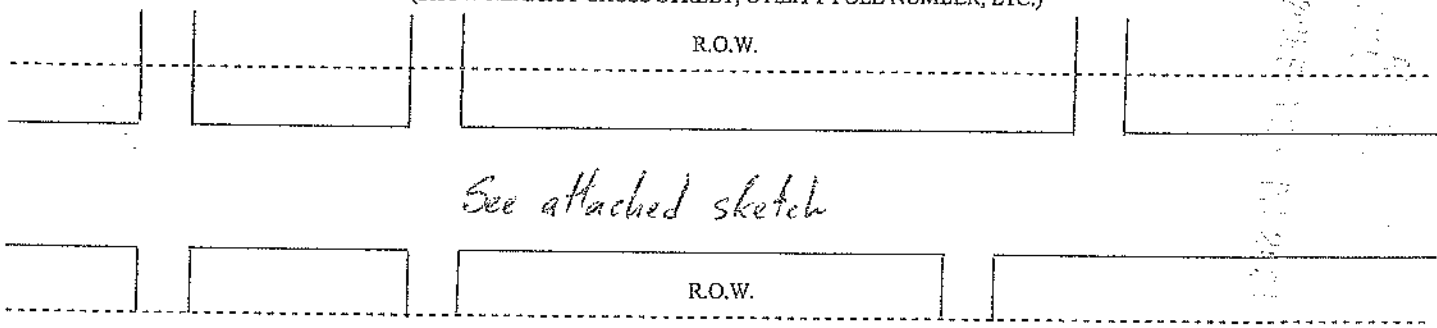

The Applicant agrees to restore the final pavement to a satisfactory condition within and not more than **FOUR MONTHS** from the date of actual opening or sooner if required by the Supervisor of Roads or his authorized representatives.

The Applicant is responsible for the opening for **TWO YEARS** after the final top is placed on the opening and the applicant has notified the Operations Division that the final top has been placed and requested and obtained a final top inspection by a Passaic County Road Inspector.

The Applicant agrees that the opening authorized by this permit, if granted, shall not be made until all conditions and requirements as stated on the reverse side and in the Passaic County Road Opening Resolution have been complied with. (Copy of Resolution available upon request)

Signature of Applicant [Signature]

Permit Number: \_\_\_\_\_

Print Name of Applicant KODJO AGBENOU

Permit Issued Date: \_\_\_\_\_

Introduced on: March 25, 2014  
Position: ENGINEER  
Official Resolution#: R20140222

Approved: \_\_\_\_\_

Jack Nigro, Supervisor of Roads

COUNTY OF PASSAIC  
 ADMINISTRATION BUILDING  
 401 GRAND STREET  
 PATERSON, NEW JERSEY 07505

OFFICE OF THE COUNTY ENGINEER  
 STEVEN J. EDMOND, P.E., COUNTY ENGINEER  
 ROOM 524  
 TELEPHONE: (973)-891-4456  
 FAX : (973)-742-3936  
 TDD : (973)-279-9786

**PERMIT AND BOND COMPUTATION INFORMATION FORM**

SHEET 1 of 2

NAME OF PROJECT: Ratzer Rd & Hamburg Tpk Underground Civil Work

COUNTY ROADWAY: Ratzer Rd & Paterson-Hamburg Turnpike

MUNICIPALITY: Wayne

Type of Existing Road Surface and / or Base Course: [ X ] - Concrete [ x ] - Stone  
 Road Last Resurfaced (PHT) (Ratzer)  
 Within 5 Years? Yes & Yes 2010 & 2013

PASSAIC COUNTY PLANNING BOARD  
 SUBDIVISION / SITE PLAN ->>>> N/A  
 NUMBER (IF APPLICABLE)

\* NOTES: If Roadway has been Resurfaced within Last 5-Years as indicated above; then Applicant must obtain Special permission from Public Works Committee to open roadway. If Project extends 1,000 linear feet, or greater, Applicant must obtain permission to open roadway from the Board of Chosen Freeholders. Processing Time ranges from 3 to 6 weeks, depending on meeting schedules. Send written request(s) in care of the Passaic County Engineer.

**INSTRUCTIONS TO AND OBLIGATIONS OF THE APPLICANT:**

**STEP 1 - ENGINEERING PERMITS (IF NOTED AS REQUIRED BELOW, APPLICANT MUST RECEIVE APPROVAL OF ENGINEERING PERMITS BEFORE PROCEEDING TO STEP 2)**

Prior to obtaining any Road Opening, Roadside Opening, or Right-of-Way Entry Permits, the Applicant may be required to first obtain various Engineering Permits from the Office of the County Engineer, and submit proof of approval of these permits, prior to the issuance of any other County Permit. The number of required permits, if any, are noted below. These Engineering Permits are issued at no charge to the Applicant.

TYPE OF ENGINEERING PERMIT	NUMBER REQUIRED	COMMENTS
Bridge Attachment	0	
Right-of-Way Access -- (Curb Cut / Driveway) Storm Drain Connection	0	
Other(s):	NONE	

**STEP 2 - ROAD OPENING / ROADSIDE OPENING / RIGHT-OF-WAY ENTRY PERMITS**

After receipt of any required Engineering Permits mentioned above, the APPLICANT, or his designated authorized CONTRACTOR, is required to bring the following Documents at the time he is applying for any Road Opening, Roadside Opening, and/or Right-of-Way Entry Permits:

1. This Original Signed Permit and Bond Computation Form.
2. Final Approval Letter issued by the Passaic County Planning Board.
3. A PRINT of the FINAL CONSTRUCTION PLAN(S) of work being completed within the County Right-of-Way.
4. Required Fee for each Permit below
5. Required Bond (to be valid for a period of two [2] years) (Refer to Amount below).
6. Copy of Insurance Certificate indicating sufficient liability coverages.

Bring the above Documents to: Passaic County Operations  
 307 Pennsylvania Avenue  
 Paterson, New Jersey 07503

Telephone: (973) - 881 - 4500  
 FAX : (973) - 742 - 2498

Failure to present any of the above Documents may either result in delays to the Applicant in obtaining the permits, or a denial in the issuance of any permits for this Project.

**Operations / Road Division Permits and Bond Computation**

	NUMBER	FEE PERMITS UNIT CHARGE	AMOUNT	NO-FEE PERMITS NUMBER
Number of Road Opening Permits to be obtained (except for curbing) (Work disturbing the Roadway Pavement - PROHIBITED from November 15 to March 31)	3	\$125.00	\$375.00	0
Number of Roadside Opening Permits to be obtained (or curbing permits): Work Outside of the Roadway Pavement (Excluding Sidewalks) Sidewalk and Driveway Apron Construction	6	\$100.00	\$600.00	0
NOTE: Concrete Curb and Sidewalk Work: PROHIBITED from November 15 to March 31.				
TOTAL NUMBER OF RIGHT-OF-WAY ENTRY PERMITS TO BE OBTAINED	9			0
TOTAL FEE FOR CHARGEABLE RIGHT-OF-WAY ENTRY PERMITS (Includes \$25 Application Fee, \$50 Inspection Fee, and \$100 per Right-of-Way Access)			\$1,050.00	
METHOD OF COMPUTATION FOR BOND AMOUNT: Estimated amount from Page 2=			\$82,444.44	

NOTE: \$ 3,000.00 minimum bond per project. If roadway has a concrete base, or has been resurfaced in the last 5 years, minimum bond is \$ 6,000.00 per project.

TOTAL AMOUNT OF BOND OR CERTIFIED CHECK TO BE POSTED FOR THE ABOVE WORK:  
 (NO BOND IF ONLY SIDEWALK IS BEING REPLACED.)

**\$82,444**

NOTE: The Permits and Bonds Amounts indicated on this form are based upon the latest plan on file on the date this form was prepared. Subsequent changes to the plans may result in adjustments to the quantities as herein contained.

This form Computed By:  
 Form Issuance Date: 1/21/2014  
 Form Effective Date: 1/21/2014  
 Verified By:

*[Signature]*  
 Timothy J. Weston, P.E., Passaic County Engineering Division

Passaic County Road /Operations Division

Form Revised May 2010 NOTE: The above information is valid for 30 Days from Effective Date. After this date, verify that information remains unchanged.

Introduced on: March 25, 2014  
 Adopted on: March 25, 2014  
 Official Resolution#: R20140222

(PERMIT /BOND BREAKDOWN ANALYSIS ON SHEET 2)

COUNTY OF PASSAIC - DEPARTMENT OF PUBLIC WORKS - ENGINEERING DIVISION  
 PERMIT COMPUTATION BREAKDOWN ANALYSIS

NAME OF PROJECT: Ratzer Rd & Hamburg Tpk Underground Civil Work

COUNTY ROADWAY: Ratzer Rd & Paterson-Hamburg Turnpike

MUNICIPALITY: Wayne

Type of Existing Road Surface and / or Base Course: | X | - Concrete | x | - Stone  
 Road Last Resurfaced (PHT) (Ratzer)  
 Within 5 Years? Yes & Yes 2010 & 2013  
 PASSAIC COUNTY PLANNING BOARD  
 SUBDIVISION / SITE PLAN ----->>>> N/A  
 NUMBER (IF APPLICABLE)

TYPE OF WORK	LOCATION OF WORK	QUANTITY	UNIT	NUMBER OF ROAD	OPENINGS ROADSIDE	BONDING RATE	ESTIMATED AMOUNT OF BOND	
Access* / Curb Cut								
New Driveway Opening			L.F.		N/A			
Close Existing Opening			L.F.		N/A			
New Curb			L.F.		N/A			
TOTAL		0	L.F.	XXXXXXXXXXXX	XXXXXXXXXXXX	\$16.00	\$0.00	
Conduits (Electric)							NO BOND	NO BOND
Manholes		3	UNIT		3	NO BOND	NO BOND	
Test Boxes								
Pipe	69KV Duct Bank	1484	L.F.	3	3	NO BOND	NO BOND	
Conduits (Telephone)							NO BOND	NO BOND
Manholes			UNIT			NO BOND	NO BOND	
Pipe			L.F.			NO BOND	NO BOND	
Pavement Widening							\$40.00	\$0.00
Trench Restorations:	Conduit	1648.9	S.Y.					
	Sanitary		S.Y.	INCLUDED	INCLUDED			
	Storm		S.Y.	IN THE	IN THE			
			S.Y.	RESPECTIVE	RESPECTIVE			
			S.Y.	FACILITIES	FACILITIES			
TOTAL		1648.9	S.Y.	XXXXXXXXXXXX	XXXXXXXXXXXX	\$50.00	\$82,444.44	
Sanitary Sewer Facilities							NO BOND	NO BOND
Manholes			UNIT			NO BOND	NO BOND	
Pipe			L.F.			NO BOND	NO BOND	
Sidewalk (@ - NO FEE)							NO BOND	NO BOND
Storm Drain Conn. *			UNIT			\$750.00	\$0.00	
Manholes			UNIT			\$2,000.00	\$0.00	
Inlets			UNIT			\$1,800.00	\$0.00	
Pipe			L.F.			\$40.00	\$0.00	
Gas Facilities							NO BOND	NO BOND
Manholes			UNIT			NO BOND	NO BOND	
Pipe			L.F.			NO BOND	NO BOND	
Pipe			L.F.			NO BOND	NO BOND	
Pipe			L.F.			NO BOND	NO BOND	
Pipe			L.F.			NO BOND	NO BOND	
OTHER WORK IN RIGHT-OF-WAY:	Relocate Hydrant		EACH				\$0.00	
	Remove Guiderail		EACH				\$0.00	
	Striping (Grind out and replace centerline)		EACH				\$0.00	
TOTALS				3	6		\$82,444.44	

\* NOTE 1: THE CONNECTION OF STORM DRAIN FACILITIES TO A PASSAIC COUNTY STORM DRAIN AND THE CONSTRUCTION OR RECONSTRUCTION OF ANY DRIVEWAY, ACCESS DRIVEWAY, OR CURB REPLACEMENT ALSO REQUIRES SEPARATE PERMITS FROM THE PASSAIC COUNTY ENGINEERING DIVISION, PRIOR TO THE ISSUANCE OF THE COMPANION ROAD OPENING OR ROADSIDE OPENING PERMITS.

Introduced on: March 25, 2014  
 Adopted on: March 26, 2014  
 Official Resolution: 20140202  
 THE TOTAL NUMBER OF PERMITS DETERMINED ABOVE DOES NOT INCLUDE THOSE ASSOCIATED WITH THE PROJECT WHICH ARE REQUIRED BY OTHER UTILITY COMPANIES (e.g., GAS, ELECTRIC, TELEPHONE, ETC.), WHO ARE REQUIRED TO OBTAIN THEIR OWN SEPARATE PERMITS FROM THE COUNTY OF PASSAIC.



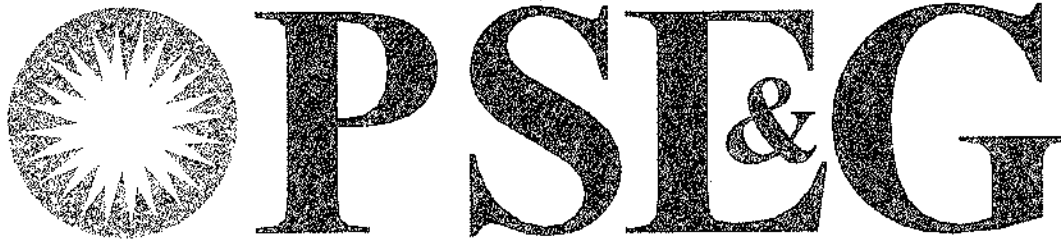

**MOBILE CONSTRUCTION WORKFORCE  
DELIVERY PROJECTS & CONSTRUCTION**

*RATZER RD & HAMBURG TPKE,*

*WAYNE*

*UNDERGROUND CIVIL WORK*

*HNC-NRP-MCL-SFL SEG 4*

# SPECS & OVERVIEW

Introduced on: **March 12, 2014**  
 Adopted on: **March 12, 2014**  
 Official Resolution#: **R2014-07-03**

## GENERAL NOTE

FOR THE INSTALLATION OF PSE&G'S ELECTRIC DISTRIBUTION UTILITIES (CONDUIT/MANHOLES), ALL PROPOSED GRADE LEVELS > PIPE IN THE FIELD SHALL BE VERIFIED BY THE SITE CONSTRUCTION COMPANY.

- NOTES:**
- ALL CONDUIT RUNS (INCLUDING LATERALS TO POLES) SHALL BE ENCASED IN 3000 PSI CONCRETE
  - CONTRACTOR SHALL SUPPLY & INSTALL 1/2" POLYPROPYLENE ROPE IN ALL NEW DUCTS.
  - ANY LOCATION WHERE 24" COVER CANNOT BE ATTAINED AT BANK WILL BE PLATED W/ 1/2" STEEL PLATE.
  - FINAL RESTORATION OF ALL AFFECTED STREET TO BE: CURB & PAVE CURB TO CURB & RESTORE

## COLOR CODE FOR PLAN VIEW PRINTS

- RED/SOLID - NEW 69KV CONDUIT & MANHOLE SYSTEM
- BLUE/DASHED - EXISTING WATER INFRASTRUCTURE
- GREEN/DASHED - SEWER SYSTEM
- VIOLET/DASHED- PSE&G GAS DISTRIBUTION
- ORANGE - TELECOMMUNICATIONS
- RED/DASHED - EXISTING PSE&G ELECTRIC SYSTEM

EXISTING UTILITIES TO BE USED AS REFERENCE ONLY.

TYPICAL TRENCH CONFIG.

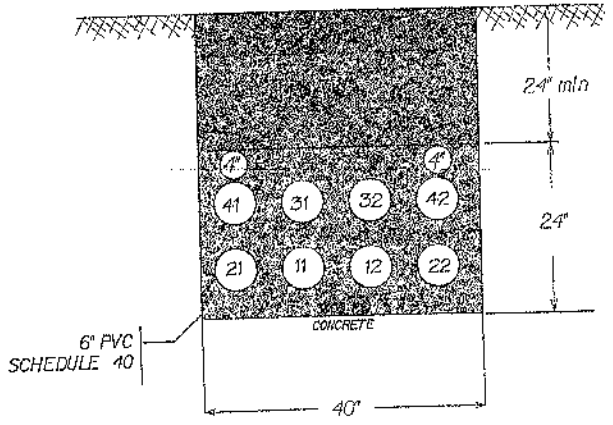

Introduced on:  
 Adopted on:  
 Official Resolution#: R20140222

March 25, 2014  
 March 25, 2014

A

A

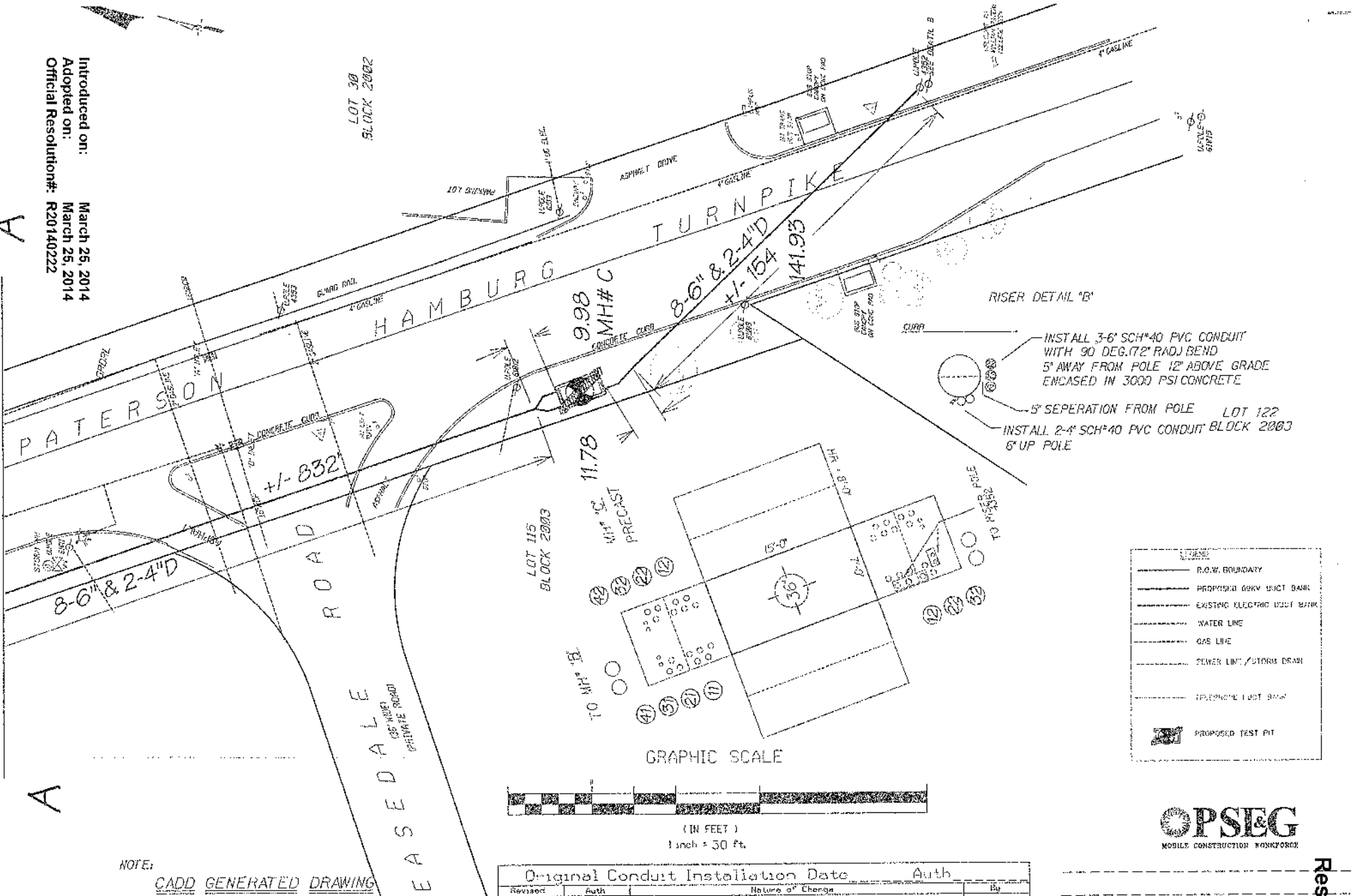

INSTALL 3-6" SCH#40 PVC CONDUIT WITH 90 DEG.(72" RADJ) BEND 5' AWAY FROM POLE 12" ABOVE GRADE ENCASED IN 3000 PSI CONCRETE

5" SEPERATION FROM POLE

INSTALL 2-4" SCH#40 PVC CONDUIT BLOCK 2003 6" UP POLE

LEGEND	
	B.O.W. BOUNDARY
	PROPOSED GERY BUCT BANK
	EXISTING ELECTRIC BUCT BANK
	WATER LINE
	GAS LINE
	SEWER LINE / STORM DRAIN
	TELEPHONE LUST BANK
	PROPOSED TEST PIT

GRAPHIC SCALE



( IN FEET )  
 1 inch = 30 ft.

NOTE:  
CADD GENERATED DRAWING  
 RETURN TO \_\_\_\_\_  
 FOR REVISIONS AND UPDATES

Original Conduit Installation Date		Auth	
Revised	Auth	Nature of Change	By



Underground System P.S.E.&G. Co.  
 Dwn By: KYA Scale: 1in.=30ft.

Res-Pg: 123-10

Introduced on: March 25, 2014  
 Adopted on: March 25, 2014  
 Official Resolution#: R20140222

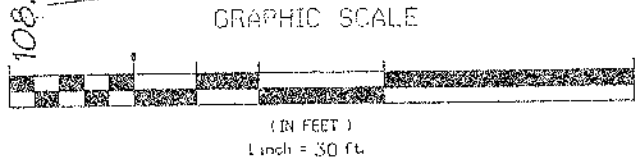
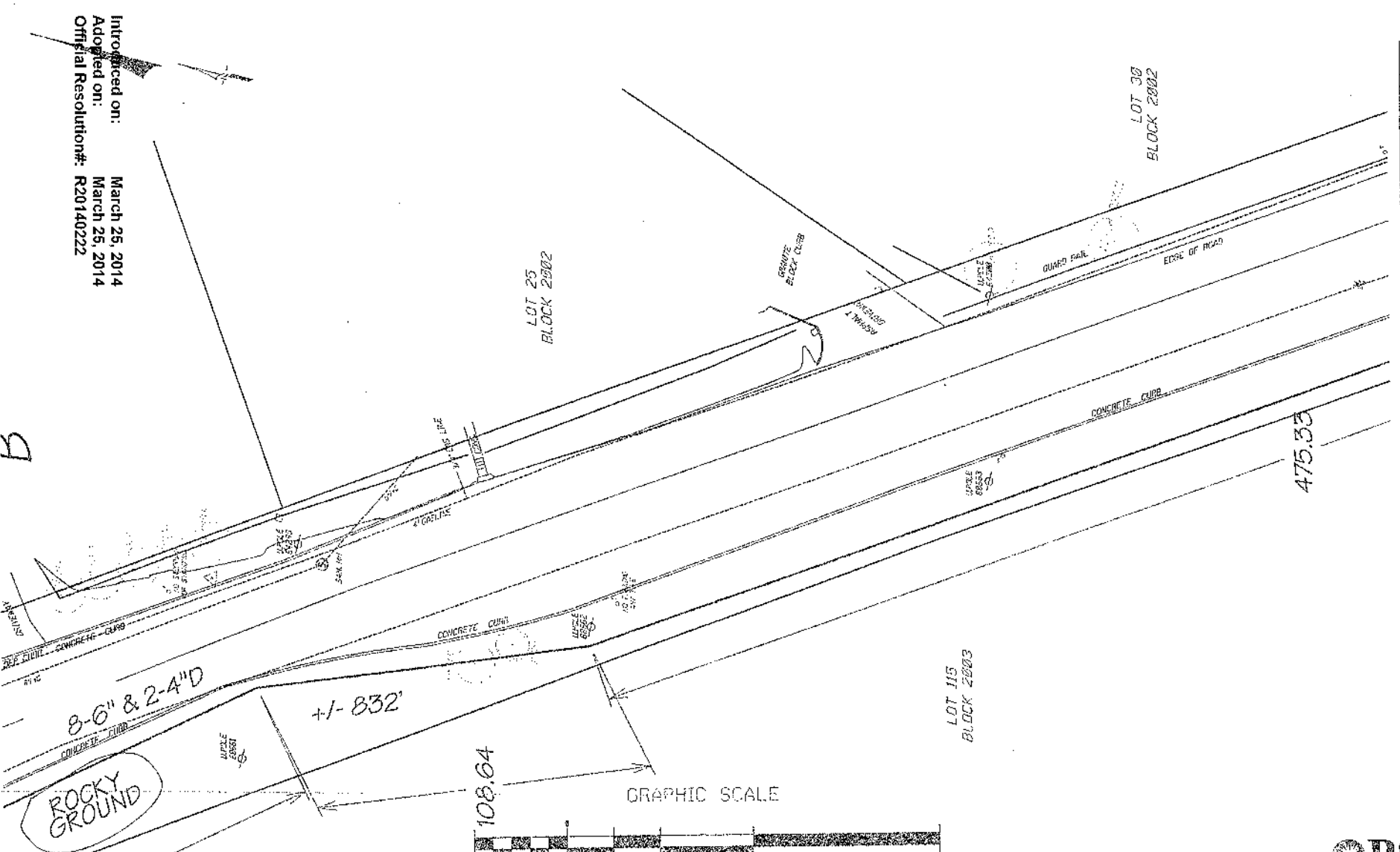

NOTE:  
CADD GENERATED DRAWING  
 RETURN TO \_\_\_\_\_  
 FOR REVISIONS AND UPDATES

Original		Conduit Installation Date	Auth
Revised	Auth	Nature of Change	By



-----  
 -----  
 Undergound System P.S.E.&G. Co.  
 Dw'n By: KVA Scale: lin.=30ft.

Res-Pg:123-11

Introduced on: March 25, 2014  
 Adopted on: March 25, 2014  
 Official Resolution: R20140222

- PROPOSED 12" PVC DUCT BANK
- PROPOSED 12" PVC DUCT BANK
- EXISTING ELECTRIC DUCT BANK
- WATER LINE
- GAS LINE
- STORM DRAIN
- UTILITY BASE
- EDGE OF CURB
- PROPOSED PIT

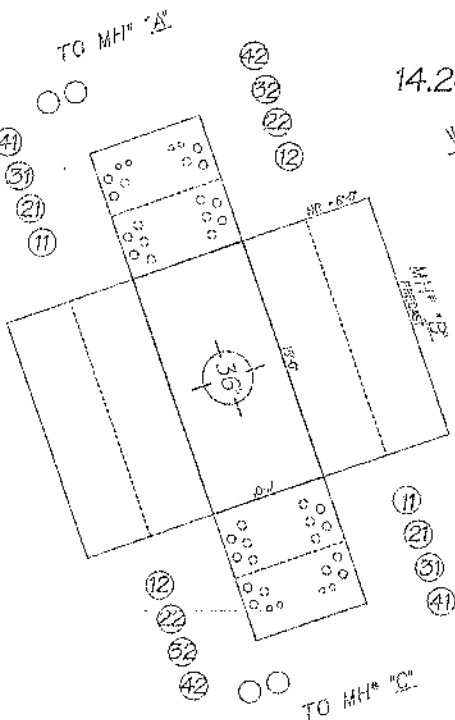

NOTE:  
**CADD GENERATED DRAWING**  
 RETURN TO \_\_\_\_\_  
 FOR REVISIONS AND UPDATES

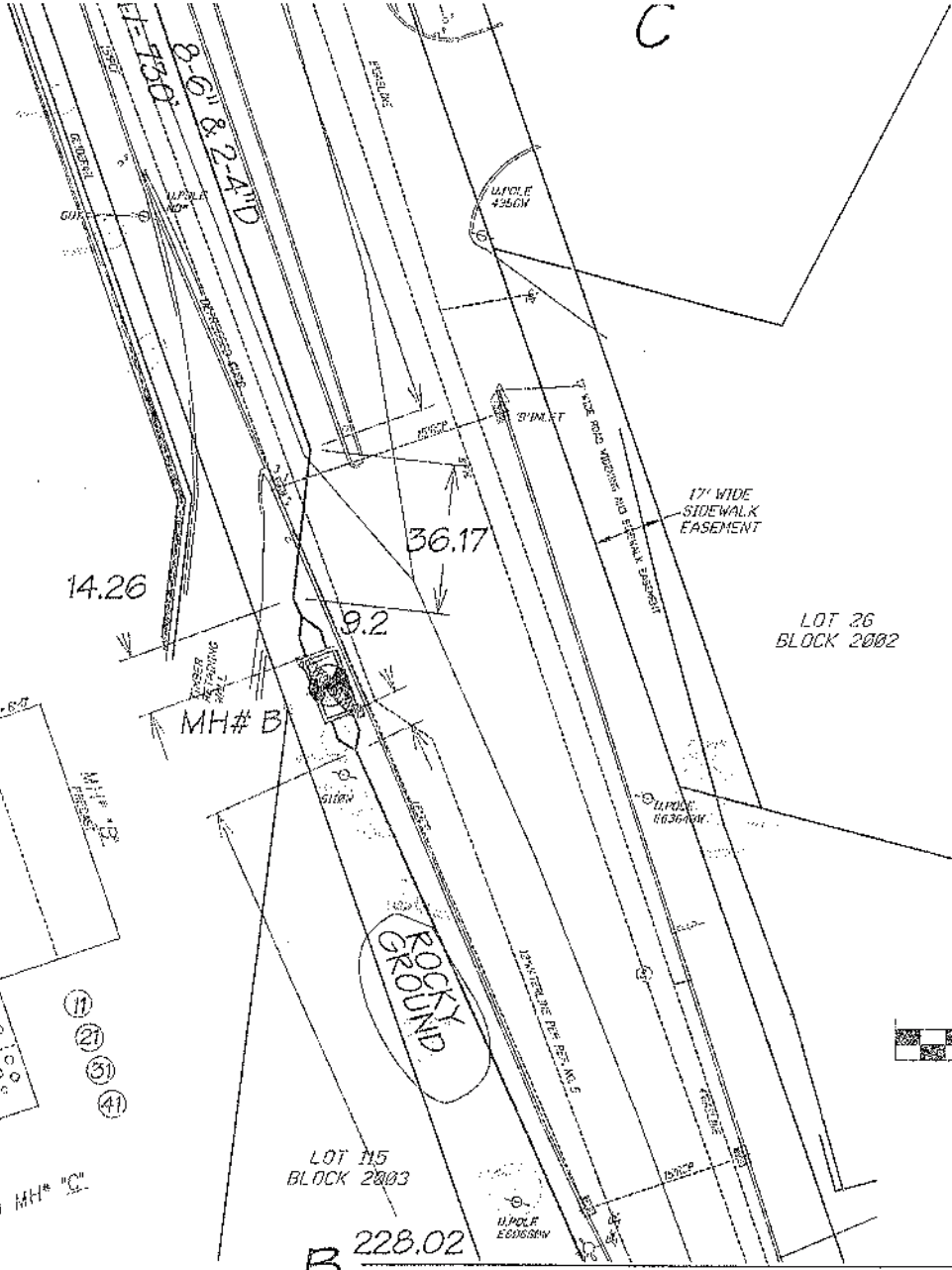

LOT 26  
 BLOCK 2002

LOT 115  
 BLOCK 2003

LOT 25  
 BLOCK 2002

GRAPHIC SCALE



1 INCH = 30 FT.

B 228.02

B

Original Conduit Installation Date		Auth.	
Revised	Auth.	Nature of Change	By



Underground System P.S.E.&G. Co.  
 Dw'n By: KVA, Scale: 1in.=30ft.

Introduced on: March 25, 2014  
 Adopted on: March 25, 2014  
 Official Resolution#: R20140222

LOT 4  
 BLOCK 2901

LOT 1  
 BLOCK 2904

LOT 27  
 BLOCK 2002

LOT 121  
 BLOCK 2003

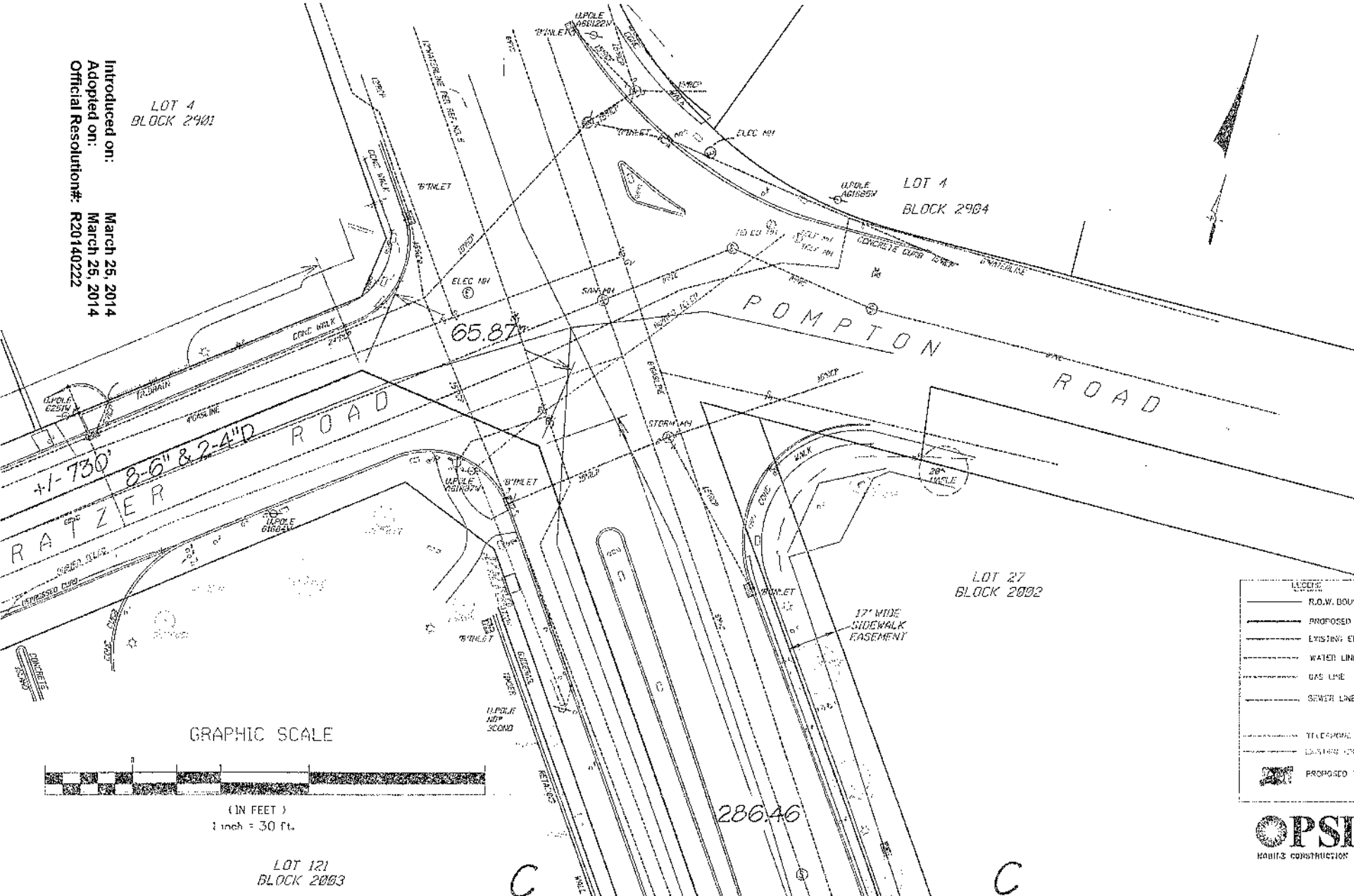

- LEGEND
- R.O.W. BOUNDARY
  - PROPOSED 60KV DUCT BANK
  - EXISTING ELECTRIC DUCT BANK
  - - - WATER LINE
  - - - GAS LINE
  - - - SEWER LINE / STORM DRAIN
  - - - TELEPHONE / FIBER OPTIC
  - ⊙ PROPOSED TEST PIT



GRAPHIC SCALE



(IN FEET)  
 1 inch = 30 ft.

NOTE:

CADD GENERATED DRAWING  
 RETURN TO \_\_\_\_\_  
 FOR REVISIONS AND UPDATES

Original Conduit Installation Date		Auth	
Revised	Auth	Nature of Change	By

Underground System P.S.E.&G. Co.  
 Dw'n By: KVA Scale: 1in.=30ft.

Res-Pg: 123-13

GRAPHIC SCALE



(IN FEET)  
1 inch = 30 ft.  
LOT 8  
BLOCK 2901

LOT 6  
BLOCK 2901

LOT 5  
BLOCK 2901  
295.77

Introduced on: March 25, 2014  
Adopted on: March 25, 2014  
Official Resolution#: R20140222

RISER DETAIL 'B'



INSTALL 3-6" SCH#40 PVC CONDUIT WITH 90 DEG.(72" RADJ BEND 5' AWAY FROM POLE 12" ABOVE GRADE ENCASED IN 3000 PSI CONCRETE

5' SEPERATION FROM POLE

INSTALL 2-4" SCH#40 PVC CONDUIT 6" UP POLE

LOT 109  
BLOCK 2901

LOT 109  
BLOCK 2901

RATZER ROAD

197.79

MH# A

RATZER ROAD

LOT 120  
BLOCK 2003

LOT 119  
BLOCK 2003

LOT 118  
BLOCK 2003

LOT 187  
BLOCK 2003

15' WIDE SIDEWALK EASEMENT

42.35

25' WIDE DRAINAGE EASEMENT

- (DASHED) — R.O.W. BOUNDARY
- (SOLID) — PROPOSED ROBY DUCT BANK
- (SOLID) — EXISTING ELECTRIC DUCT BANK
- (SOLID) — WATER LINE
- (SOLID) — GAS LINE
- (SOLID) — SEWER LINE / STORM DRAIN
- (DASHED) — TELEPHONE DUCT BANK
- (SOLID) — EXISTING OR PROPOSED
- (SOLID) — PROPOSED TEST PIT

NOTE:

CADD GENERATED DRAWING

RETURN TO \_\_\_\_\_  
FOR REVISIONS AND UPDATES

Original Conduit Installation Date		Auth	
Revised	Auth	Nature of Change	By



Underground System P.S.E.&C. Co.

Dw'n By: KVA Scale: 1in.=30ft.

Res-Pg: 123-14

# Passaic County Board of Chosen Freeholders

OFFICE OF THE  
PASSAIC COUNTY FREEHOLDERS

Director Pasquale "Pat" Lepore  
Deputy Director Theodore O. Best, Jr.  
John W. Bartlett  
Ronda Casson Cotroneo  
Terry Duffy  
Bruce James  
Hector C. Lora

401 Grand Street  
Paterson, New Jersey 07505

Tel: 973-881-4402  
Fax: 973-742-3746

Anthony J. De Nova III

Administrator

William J. Pascrell, III, Esq.

County Counsel

Louis E. Imhof, III, RMC

Clerk Of The Board



## Public Meeting (Board Meeting)

Date: Mar 25, 2014 - 5:30 PM

Location: County Administration  
220  
401 Grand Street  
Paterson, NJ 07505

Agenda: RESOLUTION APPROVING NEGOTIATED PRICE AND EASEMENT RIGHTS FOR PREMISES AT 1128 PREAKNESS AVENUE IN WAYNE, NJ IN CONNECTION WITH THE REPLACEMENT OF THE PREAKNESS AVENUE BRIDGE & CULVERT OVER THE SINGAC BROOK IN THE TOWNSHIP OF WAYNE, NEW JERSEY, ALL AS NOTED IN THE RESOLUTION

THIS RESOLUTION WAS REQUESTED BY:

REVIEWED BY:

Anthony J. De Nova III  
COUNTY ADMINISTRATOR

APPROVED AS TO FORM AND LEGALITY:

William J. Pascrell, III, Esq.  
COUNTY COUNSEL

Public Works

COMMITTEE NAME

Official Resolution#	R20140223						
Meeting Date	03/25/2014						
Introduced Date	03/25/2014						
Adopted Date	03/25/2014						
Agenda Item	I-24						
CAF #	C-04-55-116-001-920						
Purchase Req. #	TBD						
Result	Adopted						
FREEHOLDER	PRES.	ABS.	MOVE	SEC	AYE	NAY	ABST.
Lepore	✓				✓		
Best Jr	✓		✓		✓		
Bartlett	✓			✓	✓		
Cotroneo	✓				✓		
Duffy	✓				✓		
James	✓				✓		
Lora	✓				✓		

PRES.= present ABS.= absent  
MOVE= moved SEC= seconded  
AYE= yes NAY= no ABST.= abstain

Dated: March 26, 2014



**RESOLUTION APPROVING NEGOTIATED PRICE AND  
EASEMENT RIGHTS FOR PREMISES AT 1128 PREAKNESS  
AVENUE IN WAYNE, NJ IN CONNECTION WITH THE  
REPLACEMENT OF THE PREAKNESS AVENUE BRIDGE &  
CULVERT OVER THE SINGAC BROOK IN THE TOWNSHIP OF  
WAYNE, NEW JERSEY**

**WHEREAS** the County of Passaic is planning to undertake a project known as the Replacement of the Preakness Avenue Bridge & Culvert over Singac Brook (Structures #136 & 137) in the Township of Wayne, New Jersey which requires that the County obtain partial fee takings and/or easements owned by private parties; and

**WHEREAS** pursuant to the law governing eminent domain, specifically N.J.S.A. 20:3-6, the County of Passaic is first required to obtain the necessary real property acquisitions through bona fide negotiations with the affected property owners; and

**WHEREAS** the firm of PATJO Appraisal Services, Inc. of Kendall Park, New Jersey has completed the real property appraisal reports relative to the value of the lands that need to be acquired and the value of damages associated with the acquisition of the necessary lands and easements; and

**WHEREAS** by Resolution R-2014-100 dated February 11, 2014, the Board of Chosen Freeholders of the County of Passaic authorized the Office of the Passaic County Counsel to forward offers of purchase and sale to the record title holders of four (4) parcels set forth in that Resolution based upon the values of the

various fee and easements needed, as provided by PATJO Appraisal Services, Inc.; and

**WHEREAS** one of those properties, (Parcel #2), residential property at 1128 Preakness Avenue in Wayne, New Jersey (Block 1800, Lot 1), in which the County needs a permanent construction easement of 667 square feet was valued by PATJO Appraisal Services, Inc. to be \$5,400.00; and

**WHEREAS** after negotiation, the owner(s) of the property, Carlos and Nereida Zuniga, have agreed to accept the sum of \$6,500.00 for the needed permanent easement; and

**WHEREAS** this negotiated price was reviewed by the Freeholder Public Works and Buildings & Grounds Committee at its March 10, 2014 meeting and recommended for approval by the entire Board; and

**WHEREAS** a certification is attached hereto and made a part hereof indicating the availability of funds for this expenditure.

**NOW THEREFORE BE IT RESOLVED** by the Board of Chosen Freeholders of the County of Passaic that it hereby authorizes and approves the negotiated price of \$6,500.00 for easement rights for the premises at 1128 Preakness Avenue in Wayne, New Jersey in connection with the Replacement of the Preakness Avenue Bridge & Culvert over the Singac Brook in the Township of Wayne, New Jersey as more particularly described above.

**BE IT FURTHER RESOLVED** that the Director and Clerk be authorized to execute revised Contract of Purchase with the said property owners pursuant to the terms and conditions set forth in this Resolution.

March 25, 2014

CERTIFICATION OF AVAILABLE FUNDS

THIS IS TO CERTIFY THAT FUNDS ARE AVAILABLE AS FOLLOWS:

AMOUNT: \$6,500.00

APPROPRIATION: C-04-55-116-001-920

PURPOSE: To approve a negotiated price and easement rights for premises at 1128 Preakness Avenue, Wayne, NJ in connection with the Replacement of the Preakness Avenue Bridge & Culvert over the Singac Brook.

  
Michael Katz, County Treasurer

DATED: February 25, 2014

COUNTY OF PASSAIC  
RESOLUTION REQUEST FORM

1. NAME OF REQUESTER & Tel # Engineering

DESCRIPTION OF RESOLUTION (PLEASE BE SPECIFIC AS POSSIBLE)  
Resolution Approving acquisition of property at 1128 Preakness Avenue, in the amount of \$5,500.00 for the Preakness Avenue Bridge and Culvert, Wayne.

CERTIFICATION INFORMATION:

ATTACH A COPY OF THE REQUISITION FROM EDMONDS

ATTACH A COPY OF A "DETAIL BUDGET ACCOUNT STATUS INCLUDING REQUISITION ITEMS" PAGE FROM EDMONDS

PLEASE NOTE THAT RESOLUTIONS FOR ALL CONTRACT AWARDS AND OTHER EXPENDITURES REQUIRE A REQUISITION. RESOLUTION REQUESTS FOR EXPENDITURES WILL NOT BE CONSIDERED WITHOUT A REQUISITION NUMBER

3. AMOUNT OF EXPENDITURE \$6,500.00

BUDGET ACCOUNT: C-04-55-116-001-920

PURCHASE REQUISITION - PENDING ACCEPTANCE OF OFFER

4. COMMITTEE REVIEW:	<u>DATE</u>
<input type="checkbox"/> Administration & Finance	_____
<input checked="" type="checkbox"/> Public Works / Buildings & Grounds	<u>3-10-14</u>
<input type="checkbox"/> Planning & Economic Development	_____
<input type="checkbox"/> Health, Human Services & Community Affairs	_____
<input type="checkbox"/> Law & Public Safety	_____
<input type="checkbox"/> Energy	_____
<input type="checkbox"/> Other Specify: _____	_____

5. DISTRIBUTION LIST:

- Administration
- Finance
- Counsel
- Clerk to Board
- Procurement
- Other(s) Specify \_\_\_\_\_

March 4, 2014

Dear Mr. Michael H. Glovin

Re: Replacement of the Preakness Ave Bridge & Culvert over the Singac Brook in the Township of Wayne, NJ

I have received the proposal for the working that is going to be done on the bridge and I would like to address the following.

1. I would like to be assured that when all work is complete my property will be restored to its original state.
2. I would also have entry and exit access at all time during the duration of this project.
3. I am also asking that the amount of the easement be \$6,500.00.

Any questions please feel free to contact me.

Thank you,

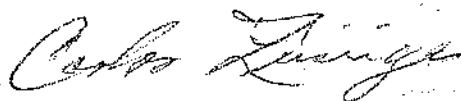

Carlos Zuniga  
1128 Preakness Ave  
Wayne, NJ 07470  
973-925-4510

# Passaic County Board of Chosen Freeholders

OFFICE OF THE  
PASSAIC COUNTY FREEHOLDERS

Director Pasquale "Pat" Lepore  
Deputy Director Theodore O. Best, Jr.  
John W. Bartlett  
Ronda Casson Cotroneo  
Terry Duffy  
Bruce James  
Hector C. Lora

401 Grand Street  
Paterson, New Jersey 07505

Tel: 973-881-4402  
Fax: 973-742-3746

Anthony J. De Nova III

Administrator

William J. Pascrell, III, Esq.

County Counsel

Louis E. Imhof, III, RMC

Clerk Of The Board



## Public Meeting (Board Meeting)

Date: Mar 25, 2014 - 5:30 PM

Location: County Administration  
220  
401 Grand Street  
Paterson, NJ 07505

Agenda: RESOLUTION APPROVING ROAD OPENING PERMIT TO PSE&G FOR INSTALLATION OF MANHOLES AND DUCT BANK ON PATERSON-HAMBURG TURNPIKE AT EASEDALE ROAD IN WAYNE, NJ, ALL AS NOTED IN THE RESOLUTION

THIS RESOLUTION WAS REQUESTED BY:

REVIEWED BY:

Anthony J. De Nova III  
COUNTY ADMINISTRATOR

APPROVED AS TO FORM AND LEGALITY:

William J. Pascrell, III, Esq.  
COUNTY COUNSEL

Public Works

COMMITTEE NAME

<b>Official Resolution#</b>	<b>R20140224</b>						
Meeting Date	03/25/2014						
Introduced Date	03/25/2014						
Adopted Date	03/25/2014						
Agenda Item	I-25						
CAF #							
Purchase Req. #							
Result	Adopted						
<b>FREEHOLDER</b>	<b>PRES.</b>	<b>ABS.</b>	<b>MOVE</b>	<b>SEC</b>	<b>AYE</b>	<b>NAY</b>	<b>ABST.</b>
Lepore	✓				✓		
Best Jr	✓		✓		✓		
Bartlett	✓			✓	✓		
Cotroneo	✓				✓		
Duffy	✓				✓		
James	✓				✓		
Lora	✓				✓		

PRES.= present ABS.= absent  
MOVE= moved SEC= seconded  
AYE= yes NAY= no ABST.= abstain

Dated: March 26, 2014

**RESOLUTION APPROVING ROAD OPENING PERMIT TO  
PSE&G FOR INSTALLATION OF MANHOLES AND DUCT BANK  
ON PATERSON-HAMBURG TURNPIKE AT EASEDALE ROAD IN  
WAYNE, NJ**

**WHEREAS** the Supervisor of Passaic County Roads is in receipt of a request for a Road Opening Permit from the Public Service Electric & Gas Company, Mobile Construction Division, to open up a section of Paterson-Hamburg Turnpike at Easedale Road in Wayne, New Jersey for a distance in excess of 1,000 linear feet to install manholes and duct bank for underground 69kv line; and

**WHEREAS** the Board of Chosen Freeholders adopted a resolution on the date of September 12, 1991 with respect to requirements concerning road opening permits relative to construction and reconstruction of County roadways; and

**WHEREAS** the Supervisor of Passaic County Roads has reviewed the aforesaid request and recommends that this Board grant permission to Public Service Electric & Gas Company to open said County road and to issue the necessary number of Road Opening Permits pursuant not only to the terms set forth above, but to the conditions set forth in the County Supervisor's letter dated March 11, 2014 (copy of said letter is attached hereto and made a part hereof); and

**WHEREAS** this application was discussed at the Public Works and Buildings & Grounds Committee meeting of March 10, 2014 and recommended to the full Board for approval;



**NOW THEREFORE BE IT RESOLVED** by the Board of Chosen Freeholders of the County of Passaic that it hereby grants permission to Public Service Electric & Gas Company to open up sections of the above-stated County road in Wayne, New Jersey for a distance in excess of 1,000 linear feet to install manholes and duct bank for underground 69kv line pursuant to the terms and conditions set forth above, and subject to the payment of all road opening fees prior to the opening of said roadway and to the adherence to the pavement trench restoration requirements of Passaic County.

March 25, 2014



# County of Passaic

Administration Building Annex

307 Pennsylvania Avenue • Paterson, New Jersey 07503

RECEIVED

2014 MAR 13 P 2:59

Jack Nigro  
Passaic County  
Supervisor of Roads

OPERATIONS DIVISION  
Tel: (973) 881-4500  
Fax: (973) 742-2498  
Cell: (973) 592-2168  
E-mail: jackn@passaiccountynj.org

March 11, 2014

Mr. Michael Glovin, Esq.  
Asst. Passaic County Counsel  
401 Grand Street  
Paterson, New Jersey 07505

Re: Resolution Request-PSE&G Co., Mobile Construction Division  
Paterson-Hamburg Turnpike, Wayne (at Easedale Road)  
**Road Opening in Excess of 1000LF**  
**Road Resurfaced within five (5) years**

Dear Mr. Glovin:

At the March 11, 2014 meeting of the Public Works and Buildings & Grounds Committee a request was heard for Public Service Electric and Gas Co., Mobile Construction Division to open county roadway to install manholes and duct bank for underground 69kv line total linear footage of 2000lf on Paterson-Hamburg Turnpike at Easedale Road in the Township of Wayne. This section of Paterson-Hamburg Turnpike was last resurfaced on August 3, 2011. The Committee directed that a resolution be made granting the request from Public Service Electric and Gas Co. on Paterson-Hamburg Turnpike at Easedale Road in the Township of Wayne. A Copy of application for the Right-of-Way entry permit and bond computation form is enclosed. If you should have any question or I can be of additional assistance, please feel free to contact me.

Thank you for your attention and your assistance with this matter.

Very truly yours,

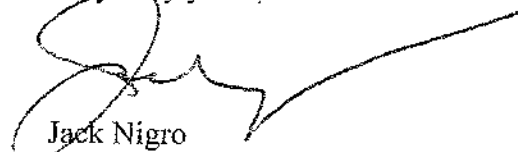
  
Jack Nigro  
Supervisor of Passaic County Roads

JN/gdj

Enclosure

Introduced on: March 25, 2014  
Adopted on: March 26, 2014  
Official Resolution#: R20140224  
Cc: Anthony DeNova, Chair, Public Works and Buildings & Grounds Committee  
Anthony DeNova, Passaic County Administrator  
Steven Edmond, P.E., Passaic County Engineer

Last resurfaced  
Paterson-Hamburg Tpk.  
8-3-2011  
Ratzer  
9-1-2010

COUNTY OF PASSAIC  
DEPARTMENT OF PUBLIC WORKS  
OPERATIONS DIVISION  
307 PENNSYLVANIA AVENUE  
PATERSON, NEW JERSEY 07503

OFFICE - (973) 881-4500 FAX - (973) 742-2498 INSPECTION - (973) 881-4503

Date 2/24/14

APPLICATION FOR RIGHT-OF-WAY ENTRY PERMIT

Name of Applicant/Contractor: PSEG (Mobile Construction Division)

Applicant's Address: 900 W. Grand St  
Elizabeth, NJ 07202

Telephone Number: 908 558 7516 Emergency 24 Hour Number: 732 221 6041

Location of Work: Paterson - Hamburg Turnpike and Ratzer Rd

Municipality: Wagner

Purpose of Work: Install manholes and duct bank for ~~etc~~ underground 69kV line

Total Linear Footage: 2,000' Excavation Start Date: \_\_\_\_\_

\*\*\* If this project or trench work consists of 1,000 or more linear feet or if this is to be done on a roadway resurfaced within the past five (5) years, permission by the Passaic County Board of Chosen Freeholders will be required prior to the issuance of any permits.

**DRAW A SKETCH BELOW SHOWING THE LOCATION OF THE WORK**  
(SHOW NEAREST CROSS STREET, UTILITY POLE NUMBER, ETC.)

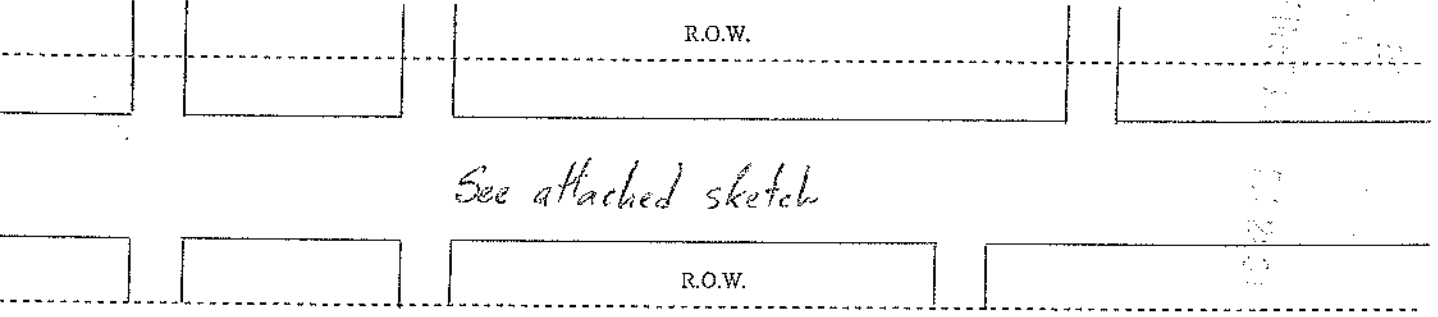

The Applicant agrees to restore the final pavement to a satisfactory condition within and not more than **FOUR MONTHS** from the date of actual opening or sooner if required by the Supervisor of Roads or his authorized representatives.  
The Applicant is responsible for the opening for **TWO YEARS** after the final top is placed on the opening and the applicant has notified the Operations Division that the final top has been placed and requested and obtained a final top inspection by a Passaic County Road Inspector.  
The Applicant agrees that the opening authorized by this permit, if granted, shall not be made until all conditions and requirements as stated on the reverse side and in the Passaic County Road Opening Resolution have been complied with. (Copy of Resolution available upon request)

Signature of Applicant: [Signature]  
Print Name of Applicant: KWAME AGBENOU  
Introduced on: March 20, 2014  
Adopted on: March 25, 2014  
Position: Special Engineer BR2014024 TECH

Permit Number: \_\_\_\_\_  
Permit Issued Date: \_\_\_\_\_  
Approved: Jack Nigro, Supervisor of Roads



COUNTY OF PASSAIC - DEPARTMENT OF PUBLIC WORKS - ENGINEERING DIVISION  
 PERMIT COMPUTATION BREAKDOWN ANALYSIS

NAME OF PROJECT:		Ratzer Rd & Hamburg Tpk Underground Civil Work						
COUNTY ROADWAY:		Ratzer Rd & Paterson-Hamburg Turnpike				MUNICIPALITY:		Wayne
Type of Existing Road Surface and / or Base Course: Road Last Resurfaced Within 5 Years? Yes & Yes		[ X ] - Concrete (PHT) 2010 & 2013	[ X ] - Stone (Ratzer)	PASSAIC COUNTY PLANNING BOARD SUBDIVISION / SITE PLAN NUMBER (IF APPLICABLE)				N/A
TYPE OF WORK	LOCATION OF WORK	QUANTITY	UNIT	NUMBER OF ROAD	OPENINGS ROADSIDE	BONDING RATE	ESTIMATED AMOUNT OF BOND	
Access* / Curb Cut								
New Driveway Opening			L.F.		N/A			
Close Existing Opening			L.F.		N/A			
New Curb			L.F.		N/A			
TOTAL		0	L.F.	XXXXXXXXXXXX	XXXXXXXXXXXX	\$18.00	\$0.00	
Conduits (Electric)						NO BOND	NO BOND	
Manholes		3	UNIT		3	NO BOND	NO BOND	
Test Boxes								
Pipe	69KV Duct Bank	1484	L.F.	3	3	NO BOND	NO BOND	
Conduits (Telephone)						NO BOND	NO BOND	
Manholes			UNIT			NO BOND	NO BOND	
Pipe			L.F.			NO BOND	NO BOND	
Pavement Widening			S.Y.			\$40.00	\$0.00	
Trench Restorations:								
	Conduit	1648.9	S.Y.					
	Sanitary		S.Y.	INCLUDED	INCLUDED			
	Storm		S.Y.	IN THE	IN THE			
			S.Y.	RESPECTIVE	RESPECTIVE			
			S.Y.	FACILITIES	FACILITIES			
TOTAL		1648.9	S.Y.	XXXXXXXXXXXX	XXXXXXXXXXXX	\$50.00	\$82,444.44	
Sanitary Sewer Facilities						NO BOND	NO BOND	
Manholes			UNIT			NO BOND	NO BOND	
Pipe			L.F.			NO BOND	NO BOND	
Sidewalk (@ - NO FEE)			S.Y.	N/A		NO BOND	NO BOND	
Storm Drain Conn. *			UNIT			\$750.00	\$0.00	
Manholes			UNIT			\$2,000.00	\$0.00	
Inlets			UNIT			\$1,800.00	\$0.00	
Pipe			L.F.			\$40.00	\$0.00	
Gas Facilities						NO BOND	NO BOND	
Manholes			UNIT			NO BOND	NO BOND	
Pipe			L.F.			NO BOND	NO BOND	
Pipe			L.F.			NO BOND	NO BOND	
Pipe			L.F.			NO BOND	NO BOND	
Pipe			L.F.			NO BOND	NO BOND	
OTHER WORK IN RIGHT-OF-WAY:								
	Relocate Hydrant		EACH				\$0.00	
	Remove Guiderail		EACH				\$0.00	
	Striping (Grind out and replace centerline)		EACH					
TOTALS				3	6		\$82,444.44	

NOTE 1: THE CONNECTION OF STORM DRAIN FACILITIES TO A PASSAIC COUNTY STORM DRAIN AND THE CONSTRUCTION OR RECONSTRUCTION OF ANY DRIVEWAY, ACCESS DRIVEWAY, OR CURB REPLACEMENT ALSO REQUIRES SEPARATE PERMITS FROM THE PASSAIC COUNTY ENGINEERING DIVISION, PRIOR TO THE ISSUANCE OF THE COMPANION ROAD OPENING OR ROADWAY PERMITS.

NOTE 2: THE TOTAL NUMBER OF PERMITS DETERMINED ABOVE DOES NOT INCLUDE THOSE ASSOCIATED WITH THE PROJECT WHICH ARE CONSTRUCTED BY OTHER UTILITY COMPANIES (e.g., GAS, ELECTRIC, TELEPHONE, ETC.), WHO ARE REQUIRED OR ELECT TO INSTALL THEIR SERVICE FACILITIES SEPARATELY. THESE UTILITIES ARE REQUIRED TO OBTAIN THEIR OWN SEPARATE PERMITS FROM THE COUNTY OF PASSAIC.

Introduced on: March 20, 2014  
 Adopted on: March 25, 2014  
 Official Resolution: R-248-14

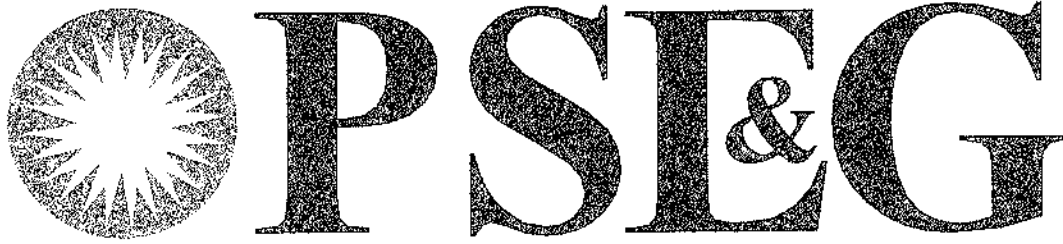

**MOBILE CONSTRUCTION WORKFORCE  
DELIVERY PROJECTS & CONSTRUCTION**

*RATZER RD & HAMBURG TPKE,*

*WAYNE*

*UNDERGROUND CIVIL WORK*

*HNC-NRP-MCL-SFL SEG 4*

# SPECS & OVERVIEW

## COLOR CODE FOR PLAN VIEW PRINTS

- RED/SOLID - NEW 69KV CONDUIT & MANHOLE SYSTEM
- BLUE/DASHED - EXISTING WATER INFRASTRUCTURE
- GREEN/DASHED - SEWER SYSTEM
- VIOLET/DASHED- PSE&G GAS DISTRIBUTION
- ORANGE - TELECOMMUNICATIONS
- RED/DASHED - EXISTING PSE&G ELECTRIC SYSTEM

EXISTING UTILITIES TO BE USED AS REFERENCE ONLY.

Introduced on: \_\_\_\_\_  
 Adopted on: \_\_\_\_\_  
 Official Resolution#: \_\_\_\_\_

## GENERAL NOTE

TO THE INSTALLATION OF PSE&G'S ELECTRIC DISTRIBUTION UTILITIES (CONDUIT/MANHOLES), ALL PROPOSED GRADE LEVELS, PIPE INVERTS, OR PROPOSED UTILITIES SHALL BE VERIFIED BY THE CONSTRUCTION COMPANY.

March 15, 2014  
 March 21, 2014  
 Resolution # \_\_\_\_\_

- 5: ALL CONDUIT RUNS (INCLUDING LATERALS TO POLES) SHALL BE ENCASED IN 3000 PSI CONCRETE
- CONTRACTOR SHALL SUPPLY & INSTALL 1/2" PROPYLENE ROPE IN ALL NEW DUCTS.
- ANY LOCATION WHERE 24" COVER CANNOT BE ATTAINED AT BANK WILL BE PLATED W/ 1/2" STEEL PLATE.
- RESTORATION OF ALL AFFECTED STREET TO BE: CURB & PAVE CURB TO CURB & RESTORE

TYPICAL TRENCH CONFIG.

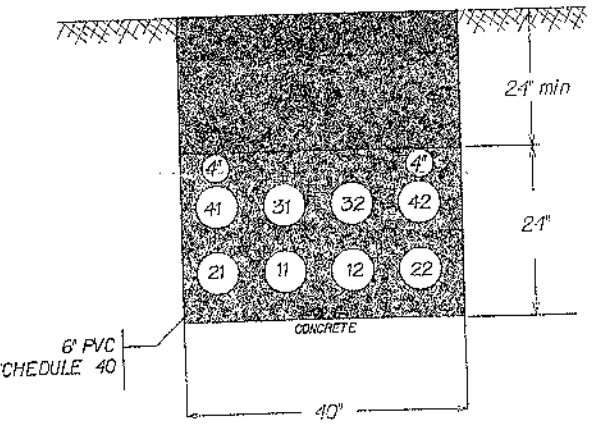

Introduced on: March 25, 2014  
 Adopted on: March 25, 2014  
 Official Resolution#: R20140224



LOT 30  
 BLOCK 2002

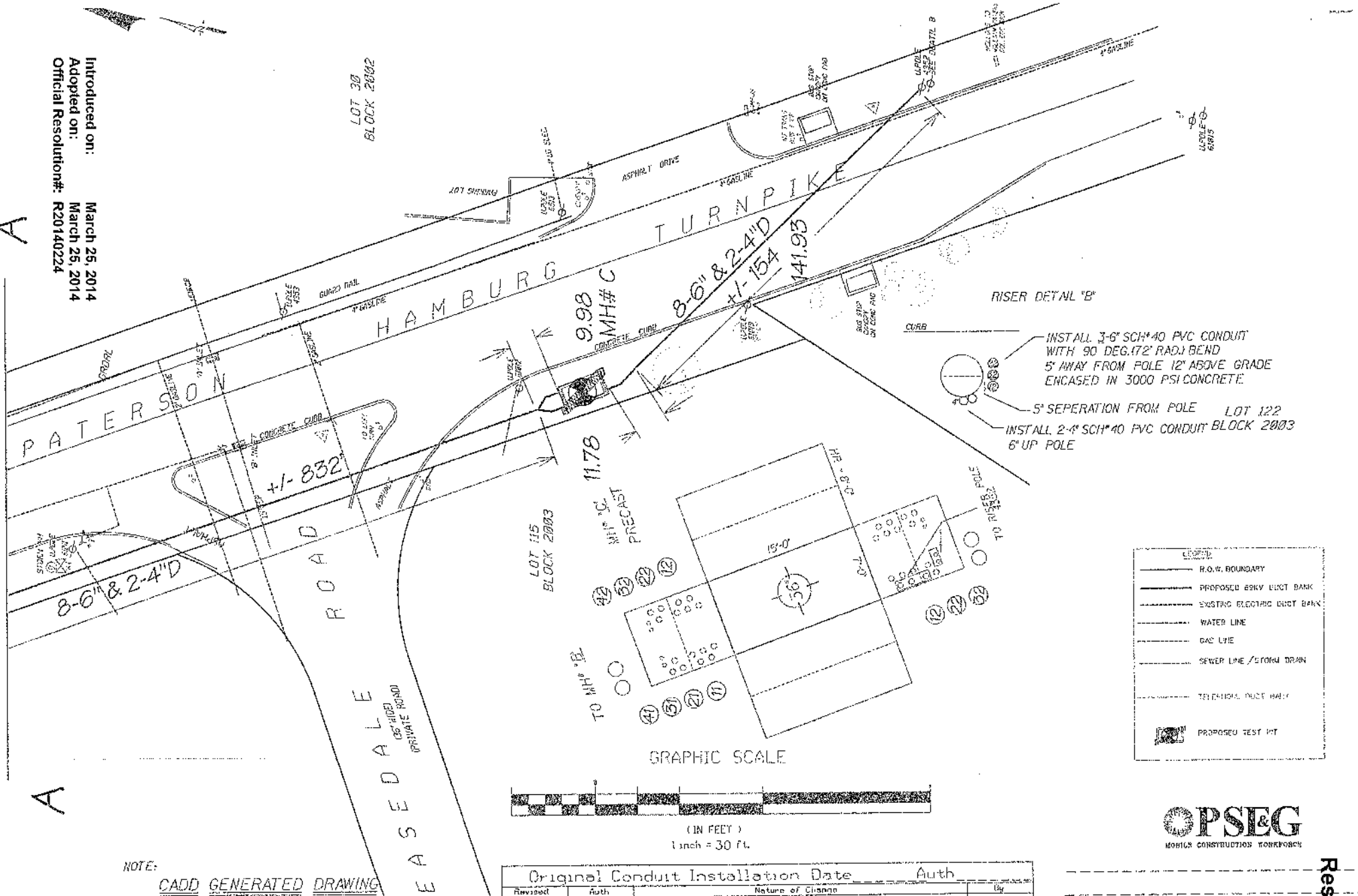

**RISER DETAIL "B"**

INSTALL 3-6" SCH#40 PVC CONDUIT WITH 90 DEG. 172" RAD. BEND 5' AWAY FROM POLE 12" ABOVE GRADE ENCASED IN 3000 PSI CONCRETE.

5' SEPERATION FROM POLE

INSTALL 2-4" SCH#40 PVC CONDUIT BLOCK 2003 6" UP POLE

**LEGEND**

- R.O.W. BOUNDARY
- PROPOSED ESBY ULST BANK
- EXISTING ELECTRIC ULST BANK
- WATER LINE
- GAS LINE
- SEWER LINE / STORM DRAIN
- TELEPHONE / CABLE WIRE
- PROPOSED TEST PIT

GRAPHIC SCALE



(IN FEET)  
 1 inch = 30 ft.

NOTE:  
CADD GENERATED DRAWING  
 RETURN TO \_\_\_\_\_  
 FOR REVISIONS AND UPDATES

Original Conduit Installation Date		Auth	
Revised	Auth	Nature of Change	By



Underground System P.S.E.&G. Co.  
 Dwn By: KYA. Scale: 1in.=30ft.

Res-Pg:125-10



Introduced on: March 25, 2014  
 Adopted on: March 25, 2014  
 Official Resolution#: R20140224

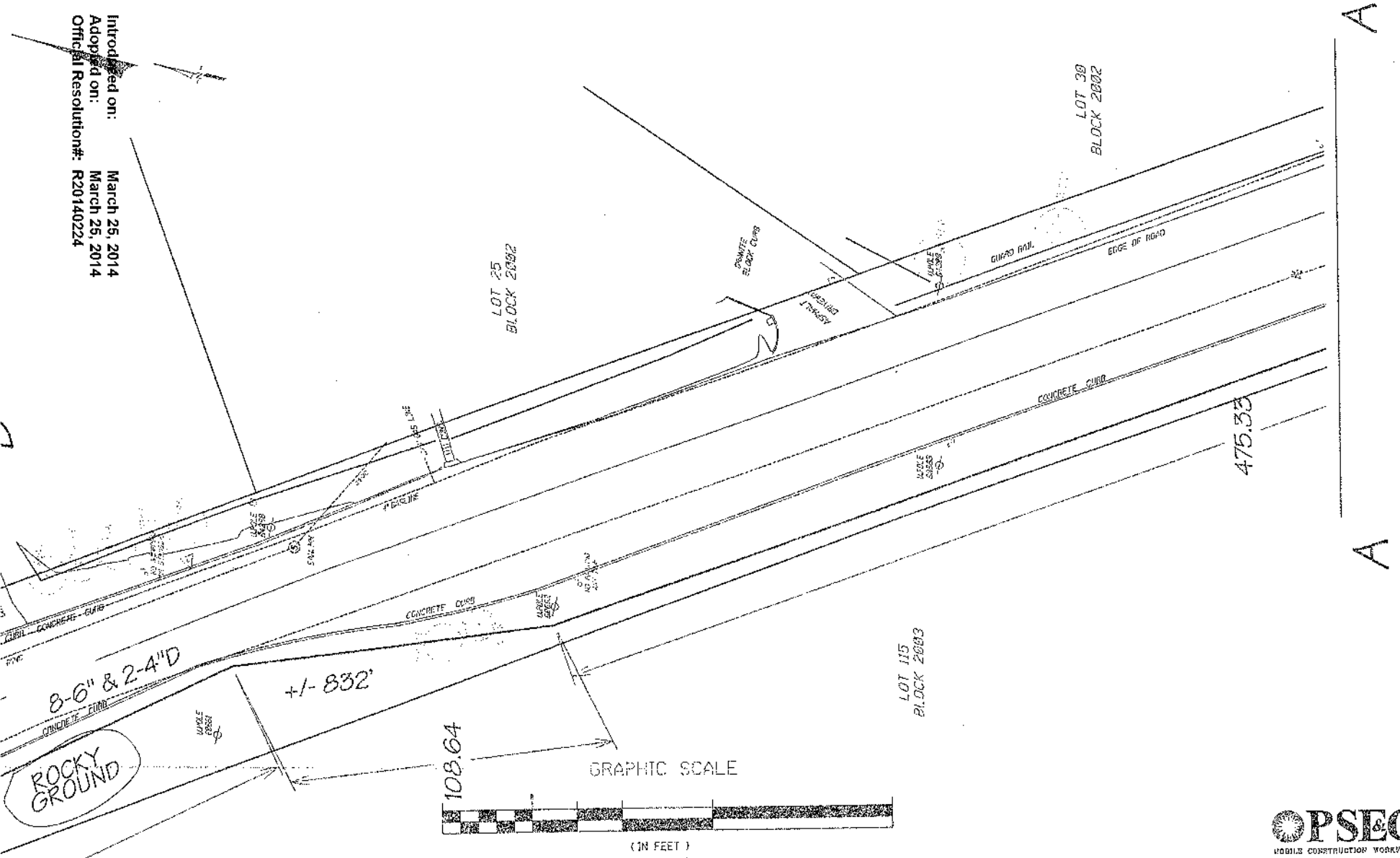

NOTE:  
CADD GENERATED DRAWING  
 RETURN TO \_\_\_\_\_  
 FOR REVISIONS AND UPDATES

Original		Installation Date	Auth
Revised	Auth	Nature of Change	By



Underground System P.S.E.&G. Co.  
 Dwn By: KVA Scale: 1in.=30ft.

Introduced by  
 March 25, 2014  
 Adopted by  
 March 25, 2014  
 Official Resolution  
 R20140224

	FLOOD PROTECTION DUCT BANK
	PROPOSED ELECTRIC DUCT BANK
	EXISTING ELECTRIC DUCT BANK
	WATER MAIN
	GAS MAIN
	SEWER MAIN
	TELEPHONE MAIN
	FIRE MAIN
	PROPOSED ELECTRIC

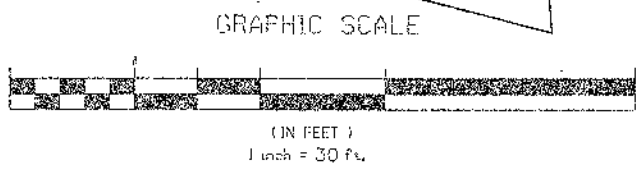
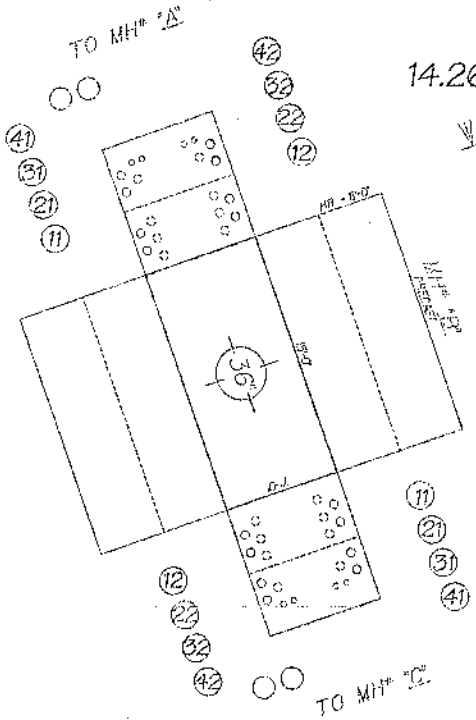
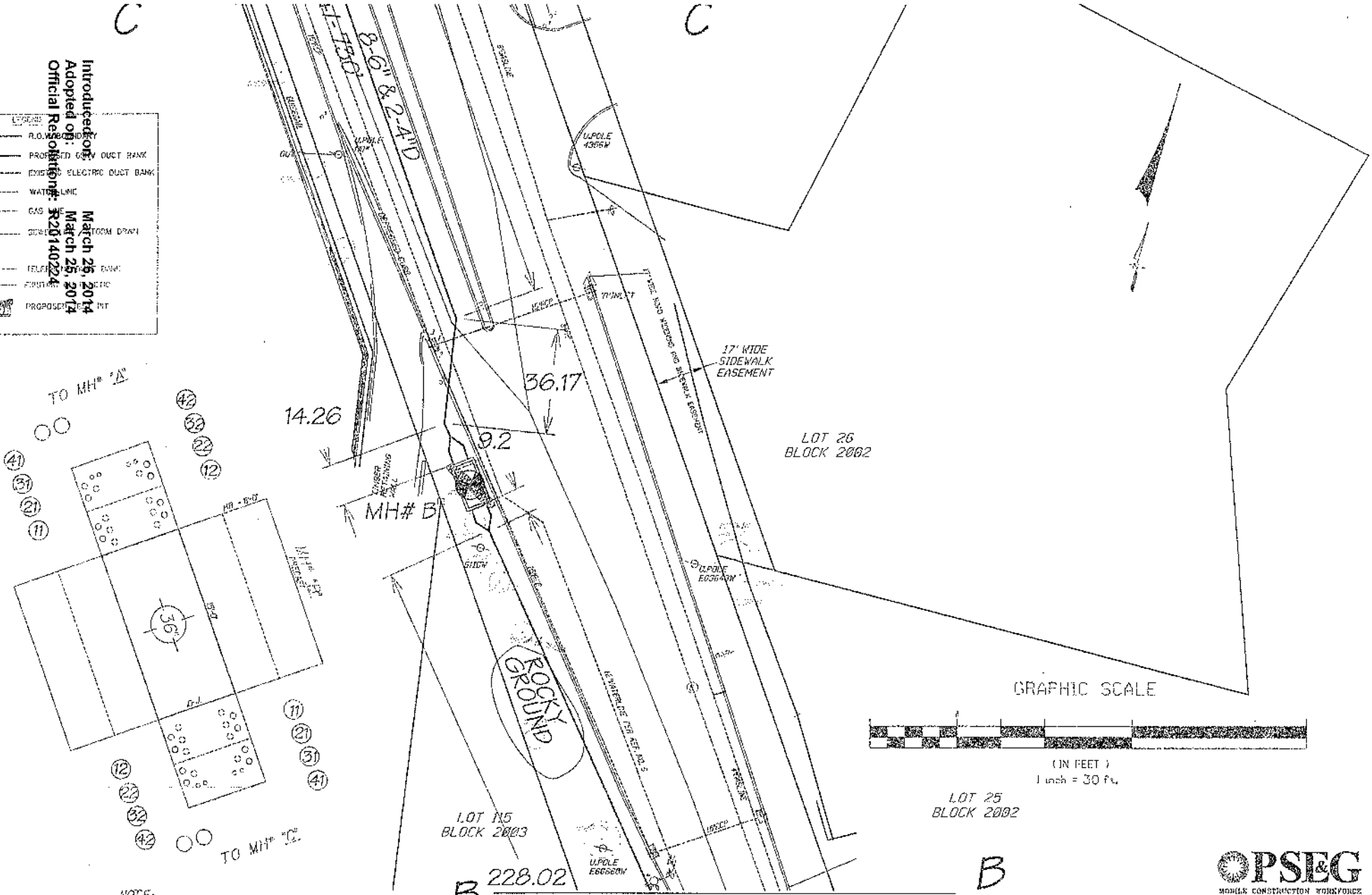

NOTE:  
CADD GENERATED DRAWING  
 RETURN TO \_\_\_\_\_  
 FOR REVISIONS AND UPDATES

B 228.02

Original Conduit Installation Date		Auth	
Revised	Auth	Nature of Change	By



Underground System P.S.E.&G. Co.  
 Dw'n By: KVA Scale: 1 in. = 30 ft.

Res-Pg: 1.25-12

Introduced on: LOT 4  
BLOCK 2901  
Adopted on: March 25, 2014  
Official Resolution#: R20140224

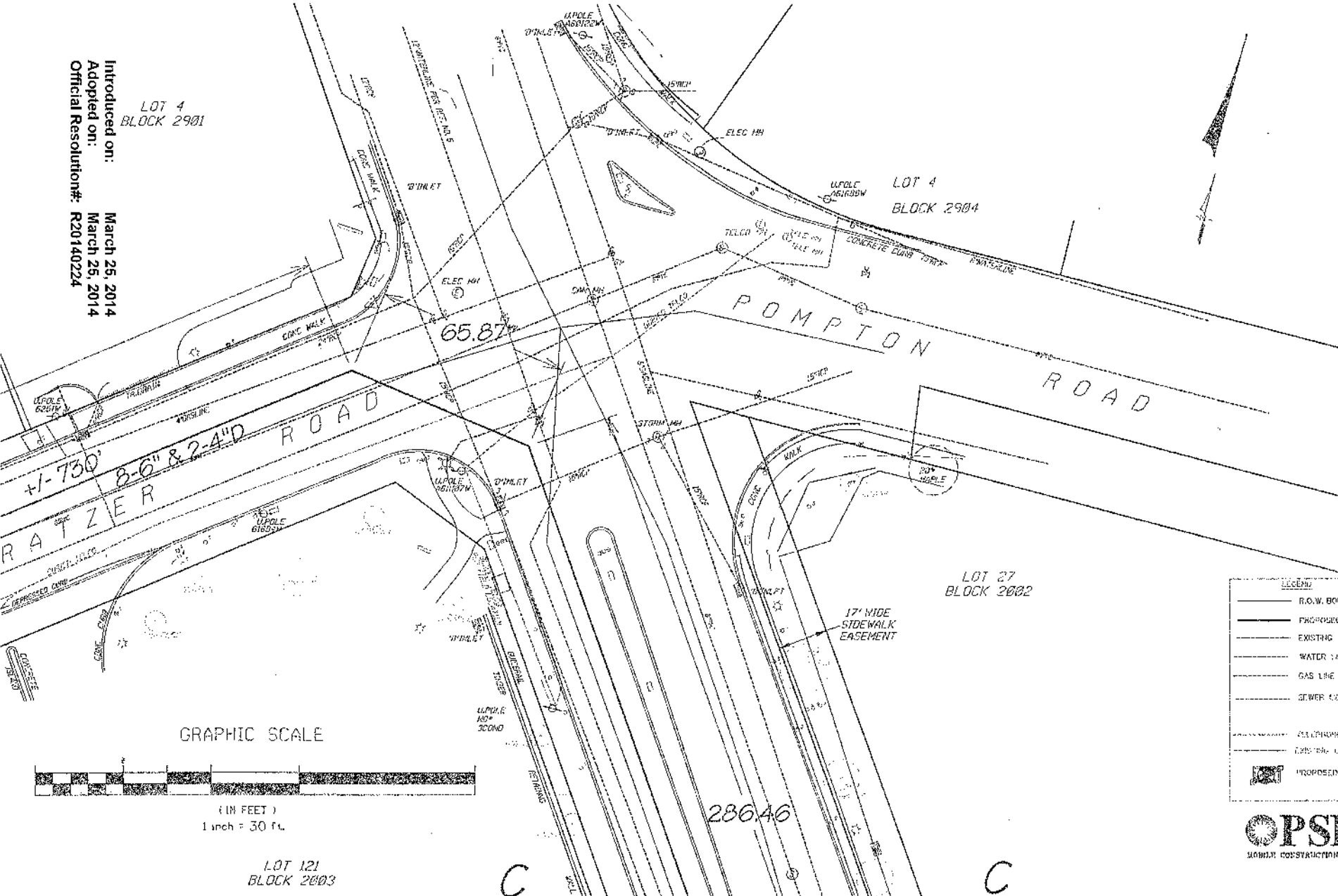

GRAPHIC SCALE



( IN FEET )  
1 inch = 30 ft.

LOT 121  
BLOCK 2803

NOTE:

CADD GENERATED DRAWING

RETURN TO \_\_\_\_\_  
FOR REVISIONS AND UPDATES

Original Conduit Installation Date		Auth	
Revised	Auth	Nature of Change	By

**LEGEND**

- R.O.W. BOUNDARY
- PROPOSED 60KV DUCT BANK
- EXISTING ELECTRIC DUCT BANK
- WATER LINE
- GAS LINE
- SEWER LINE / STORM DRAIN
- TELEPHONE DUCT BANK
- EXISTING ELECTRIC
- PROPOSED TEST PIT



-----  
Underground System P.S.E.&G. Co.  
Dw'n By: KVA Scale: 1 in. = 30 ft.  
-----

Res-Pg: 125-13

GRAPHIC SCALE

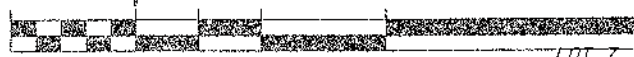

(IN FEET)  
1 inch = 30 ft.  
LOT 8  
BLOCK 2901

LOT 6  
BLOCK 2901

LOT 7  
BLOCK 2901

LOT 5  
BLOCK 2901

Introduced on: March 25, 2014  
Adopted on: March 25, 2014  
Official Resolution#: R20140324

RISER DETAIL 'B'

INSTALL 3-6" SCH#40 PVC CONDUIT WITH 90 DEG.(72" RAD.) BEND 5' AWAY FROM POLE 12" ABOVE GRADE ENCASED IN 3000 PSI CONCRETE

5' SEPERATION FROM POLE

INSTALL 2-4" SCH#40 PVC CONDUIT 6" UP POLE

LOT 109  
BLOCK 2901

LOT 109  
BLOCK 2901

LOT 120  
BLOCK 2003

LOT 119  
BLOCK 2003

LOT 118  
BLOCK 2003

LOT 187  
BLOCK 2003

NOTE:

CADD GENERATED DRAWING

RETURN TO \_\_\_\_\_  
FOR REVISIONS AND UPDATES

Original Conduit Installation Date		Auth	
Revised	Auth	Reason of Change	By

LEGEND

- F.O.W. BOUNDARY
- PROPOSED 8'X4' GUST BARR
- EXISTING ELECTRIC GUST BARR
- WATER LINE
- GAS LINE
- SEWER LINE / STORM DRAIN
- TELEPHONE CABLE BARR
- EXISTING OR TELETYPE
- PROPOSED TEST PIT



Underground System P.S.E.&G. Co.

Dwn By: KVA Scale: 1in.=30ft.

Res-Pg: 125-14

# Passaic County Board of Chosen Freeholders

OFFICE OF THE  
PASSAIC COUNTY FREEHOLDERS

Director Pasquale "Pat" Lepore  
Deputy Director Theodore O. Best, Jr.  
John W. Bartlett  
Ronda Casson Cotroneo  
Terry Duffy  
Bruce James  
Hector C. Lora

401 Grand Street  
Paterson, New Jersey 07505

Tel: 973-881-4402  
Fax: 973-742-3746

Anthony J. De Nova III

Administrator

William J. Pascrell, III, Esq.

County Counsel

Louis E. Imhof, III, RMC

Clerk Of The Board



## Public Meeting (Board Meeting)

Date: Mar 25, 2014 - 5:30 PM

Location: County Administration  
220  
401 Grand Street  
Paterson, NJ 07505

Agenda: RESOLUTION APPROVING ROAD OPENING REQUEST FOR KEMSCO CONSTRUCTION AND EQUIPMENT CO., INC. TO OPEN SECTIONS OF VAN HOUTEN AVENUE IN CLIFTON, NEW JERSEY, ALL AS NOTED IN THE RESOLUTION

THIS RESOLUTION WAS REQUESTED BY:

REVIEWED BY:

Anthony J. De Nova III  
COUNTY ADMINISTRATOR

APPROVED AS TO FORM AND LEGALITY:

William J. Pascrell, III, Esq.  
COUNTY COUNSEL

Public Works

COMMITTEE NAME

<b>Official Resolution#</b>	<b>R20140225</b>						
Meeting Date	03/25/2014						
Introduced Date	03/25/2014						
Adopted Date	03/25/2014						
Agenda Item	I-26						
CAF #							
Purchase Req. #							
Result	Adopted						
<b>FREEHOLDER</b>	<b>PRES.</b>	<b>ABS.</b>	<b>MOVE</b>	<b>SEC</b>	<b>AYE</b>	<b>NAY</b>	<b>ABST.</b>
Lepore	✓				✓		
Best Jr	✓		✓		✓		
Bartlett	✓			✓	✓		
Cotroneo	✓				✓		
Duffy	✓				✓		
James	✓				✓		
Lora	✓				✓		

PRES.= present ABS.= absent  
MOVE= moved SEC= seconded  
AYE= yes NAY= no ABST.= abstain

Dated: March 26, 2014

**RESOLUTION APPROVING ROAD OPENING REQUEST FOR  
KEMSCO CONSTRUCTION AND EQUIPMENT CO., INC. TO  
OPEN SECTIONS OF VAN HOUTEN AVENUE IN CLIFTON, NEW  
JERSEY**

**WHEREAS** the Supervisor of Passaic County Roads is in receipt of a request for a Road Opening Permit from Kemsco Construction and Equipment Co., Inc. to open up sections of Van Houten Avenue from Van Vleit Court to Clifton Avenue in Clifton, New Jersey for a distance in excess of 1,000 linear feet for the installation of electric pipe conduit by PSE&G Co.; and

**WHEREAS** the Board of Chosen Freeholders adopted a resolution on the date of September 12, 1991 with respect to requirements concerning road opening permits relative to construction and reconstruction of County roadways; and

**WHEREAS** the Supervisor of Passaic County Roads has reviewed the aforesaid request and recommends that this Board grant permission to Kemsco Construction and Equipment Co., Inc. to open said County road and to issue the necessary number of Road Opening Permits pursuant not only to the terms set forth above, but to the conditions set forth in the County Supervisor's letter dated March 11, 2014 (copy of said letter is attached hereto and made a part hereof); and

**WHEREAS** this application was discussed at the Public Works and Buildings & Grounds Committee meeting of March 10, 2014 and recommended to the full Board for approval;

**NOW THEREFORE BE IT RESOLVED** by the Board of Chosen Freeholders of the County of Passaic that it hereby grants

permission to Kemsco Construction and Equipment Co., Inc. to open up sections of the above-stated County road in Clifton, New Jersey for a distance in excess of 1,000 linear feet in order for PSE&G Co. to install electric pipe conduit pursuant to the terms and conditions set forth above, and subject to the payment of all road opening fees prior to the opening of said roadway and to the adherence to the pavement trench restoration requirements of Passaic County.

March 25, 2014



# County of Passaic

Administration Building Annex

307 Pennsylvania Avenue • Paterson, New Jersey 07503

RECEIVED

2014 MAR 13 P 2:59

**Jack Nigro**  
Passaic County  
Supervisor of Roads

OPERATIONS DIVISION

Tel: (973) 881-4500  
Fax: (973) 742-2498  
Cell: (973) 592-2168

E-mail: jackn@passaiccountynj.org

March 11, 2014

PASSAIC COUNTY  
COUNSEL'S OFFICE

Mr. Michael Glovin, Esq.  
Asst. Passaic County Counsel  
401 Grand Street  
Paterson, New Jersey 07505

Re: Resolution Request-Kemsco Construction and Equipment Co., Inc.  
Van Houten Ave, From Van Vleit Ct to Clifton Ave, Clifton  
**Road Opening in Excess of 1000LF**

Dear Mr. Glovin:

At the March 11, 2014 meeting of the Public Works and Buildings & Grounds Committee a request was heard for Kemsco Construction and Equipment Co., Inc. to open county roadway to install electric pipe conduit for PSE&G total linear footage of 1150lf at Van Houten Avenue, from Van Vleit Court to Clifton Avenue in the City of Clifton. The Committee directed that a resolution be made granting the request from Kemsco Construction and Equipment Co., Inc. to install electric pipe conduit in the City of Clifton. A Copy of application for the Right-of-Way entry permit and bond computation form is enclosed

If you should have any question or I can be of additional assistance, please feel free to contact me.

Thank you for your attention and your assistance with this matter.

Very truly yours,

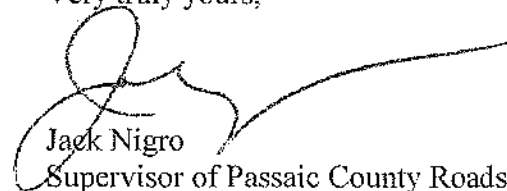
  
Jack Nigro  
Supervisor of Passaic County Roads

JN/gdj

Enclosure

Introduced on: March 25, 2014

Adopted on: Cc: March 25, 2014  
Official Resolution#: R20140225  
Anthony DeNova, Passaic County Administrator  
Steven Edmond, P.E., Passaic County Engineer



COUNTY OF PASSAIC  
DEPARTMENT OF PUBLIC WORKS  
OPERATIONS DIVISION  
307 PENNSYLVANIA AVENUE  
PATERSON, NEW JERSEY 07503

OFFICE - (973) 881-4500

FAX - (973) 742-2498

INSPECTION - (973) 881-4503

Date 3/3/2014

APPLICATION FOR RIGHT-OF-WAY ENTRY PERMIT

Name of Applicant/Contractor: KEMSCO CONSTRUCTION AND EQUIPMENT CO. INC.

Applicant's Address: 139 HARPER ST  
NEWARK NJ. 07114

Telephone Number: 973-733-2255 Emergency 24 Hour Number: 973-733-2255

Location of Work: VAN HOUTEN AVE FROM VAN VLIET CT TO CLIFTON AVE.

Municipality: CLIFTON

Purpose of Work: INSTALL ELECTRIC PIPE CONDUIT  
FOR PSE & G.

Total Linear Footage: 1150 Excavation Start Date: APRIL 1<sup>ST</sup> 2014

\*\*\* If this project or trench work consists of 1,000 or more linear feet or if this is to be done on a roadway resurfaced within the past five (5) years, permission by the Passaic County Board of Chosen Freeholders will be required prior to the issuance of any permits.

**DRAW A SKETCH BELOW SHOWING THE LOCATION OF THE WORK**  
(SHOW NEAREST CROSS STREET, UTILITY POLE NUMBER, ETC.)

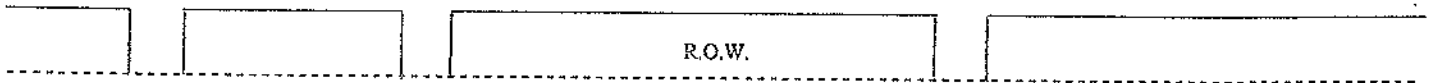
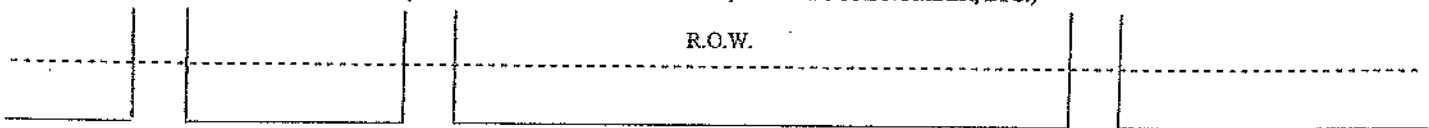

The Applicant agrees to restore the final pavement to a satisfactory condition within and not more than **FOUR MONTHS** from the date of actual opening or sooner if required by the Supervisor of Roads or his authorized representatives.

The Applicant is responsible for the opening for **TWO YEARS** after the final top is placed on the opening and the applicant has notified the Operations Division that the final top has been placed and requested and obtained a final top inspection by a Passaic County Road Inspector.

The Applicant agrees that the opening authorized by this permit, if granted, shall not be made until all conditions and requirements as stated on the reverse side and in the Passaic County Road Opening Resolution have been complied with. (Copy of Resolution available upon request)

Signature of Applicant 

Print Name of Applicant RICHARD EVANS

Introduced on: March 25, 2014  
Position: Adopted on March 25, 2014  
Official Resolution#: R20140225

Permit Number: \_\_\_\_\_

Permit Issued Date: \_\_\_\_\_

Approved: \_\_\_\_\_

Jack Nigro, Supervisor of Roads



COUNTY OF PASSAIC - DEPARTMENT OF PUBLIC WORKS - ENGINEERING DIVISION  
 PERMIT COMPUTATION BREAKDOWN ANALYSIS

NAME OF PROJECT:		PSE&G NE Grid Reliability Project					
COUNTY ROADWAY:		Van Houten Ave, Van Velt to Clifton		MUNICIPALITY:		Clifton	
Type of Existing Road Surface and / or Base Course:		[ x ] - Concrete [ ] - Stone		PASSAIC COUNTY PLANNING BOARD SUBDIVISION / SITE PLAN NUMBER (IF APPLICABLE) ->>>> N/A			
Road Last Resurfaced Within 5 Years?		No					
TYPE OF WORK	LOCATION OF WORK	QUANTITY	UNIT	NUMBER OF ROAD	OPENINGS ROADSIDE	BONDING RATE	ESTIMATED AMOUNT OF BOND
Access* / Curb Cut							
New Driveway Opening			L.F.		N/A		
Close Existing Opening			L.F.		N/A		
New Curb			L.F.		N/A		
TOTAL		0	L.F.			\$16.00	\$0.00
Conduits (Electric)						NO BOND	NO BOND
Manholes	21"X8" Electrical Manhole	1	UNIT	1		NO BOND	NO BOND
Fiber Optic Hand Holds	In Road	1	Unit	1			
Test Boxes	Under Sidewalk	1	Unit		1		
Pipe	10" steel conduit, 250KV Pipe-type conduit	1200	L.F.	4		NO BOND	NO BOND
Conduits (Telephone)						NO BOND	NO BOND
Manholes			UNIT			NO BOND	NO BOND
Pipe			L.F.			NO BOND	NO BOND
Pavement Widening			S.Y.			\$40.00	\$0.00
Trench Restorations:	Conduit	533.30	S.Y.		INCLUDED		
	Hand Holds	1	S.Y.		IN THE		
	Test Boxes	1	S.Y.		RESPECTIVE		
	Gas	43.1	S.Y.		RESPECTIVE		
	Manholes	26	S.Y.		FACILITIES		
TOTAL		604.4	S.Y.			\$50.00	\$30,220.00
Sanitary Sewer Facilities						NO BOND	NO BOND
Sidewalk (@ - NO FEE)	at Test Boxes	1	S.Y.	N/A	1	NO BOND	NO BOND
Storm Drain Conn. *			UNIT			\$750.00	\$0.00
Manholes			UNIT			\$2,000.00	\$0.00
Inlets			UNIT			\$1,800.00	\$0.00
Pipe			L.F.			\$40.00	\$0.00
Gas Facilities						NO BOND	NO BOND
Manholes			UNIT			NO BOND	NO BOND
Pipe	Relocate Existing Gas Line	97	L.F.	1		NO BOND	NO BOND
Pipe			L.F.			NO BOND	NO BOND
Pipe			L.F.			NO BOND	NO BOND
Pipe			L.F.			NO BOND	NO BOND
OTHER WORK IN RIGHT-OF-WAY:	Relocate Hydrant		EACH				\$0.00
	Remove Guiderail		EACH				\$0.00
	Striping (Grind out and replace centerline)		EACH				
TOTALS				7	2		\$30,220.00

NOTE 1: THE CONNECTION OF STORM DRAIN FACILITIES TO A PASSAIC COUNTY STORM DRAIN AND THE CONSTRUCTION OR RECONSTRUCTION OF ANY DRIVEWAY, ACCESS DRIVEWAY, OR CURB REPLACEMENT ALSO REQUIRES SEPARATE PERMITS FROM THE PASSAIC COUNTY ENGINEERING DIVISION, PRIOR TO THE ISSUANCE OF THE COMPANION ROAD OPENING OR ROADSIDE OPENING PERMITS.

NOTE 2: THE TOTAL NUMBER OF PERMITS DETERMINED ABOVE DOES NOT INCLUDE THOSE ASSOCIATED WITH THE PROJECT WHICH ARE CONSTRUCTED BY OTHER UTILITY COMPANIES (e.g., GAS, ELECTRIC, TELEPHONE, ETC.), WHO ARE REQUIRED OR ELECT TO INSTALL THEIR SERVICE FACILITIES SEPARATELY. THESE UTILITIES ARE REQUIRED TO OBTAIN THEIR OWN SEPARATE PERMITS FROM THE COUNTY OF PASSAIC.

Introduced on: March 25, 2014  
 Adopted on: March 25, 2014  
 Official Resolution#: R20140225

NOT BONDABLE UNDER PASSAIC COUNTY REGULATIONS.

Introduced on: March 25, 2014  
 Adopted on: March 25, 2014  
 Official Resolution#: R20140225

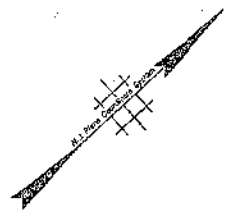

CURVE DATA	
CURVE #15	
LC= 200.00	
PC= 695.24	
PT= 895.24	
PI= 795.24	
TA= 90.0000	
EA= 207.435 (P)	
EA= 207.435 (P)	
PI= 795.24	

CURVE DATA	
CURVE #16	
LC= 200.00	
PC= 800.00	
PT= 1000.00	
PI= 900.00	
TA= 90.0000	
EA= 800.000 (P)	
EA= 800.000 (P)	
PI= 1000.00	

  

CURVE DATA	
CURVE #17	
LC= 200.00	
PC= 900.00	
PT= 1100.00	
PI= 1000.00	
TA= 90.0000	
EA= 900.000 (P)	
EA= 900.000 (P)	
PI= 1100.00	

  

CURVE DATA	
CURVE #18	
LC= 200.00	
PC= 1000.00	
PT= 1200.00	
PI= 1100.00	
TA= 90.0000	
EA= 1000.000 (P)	
EA= 1000.000 (P)	
PI= 1200.00	

NOTES:  
 1. GAS RELOCATION SHALL BE COORDINATED WITH UTILITY OWNER.

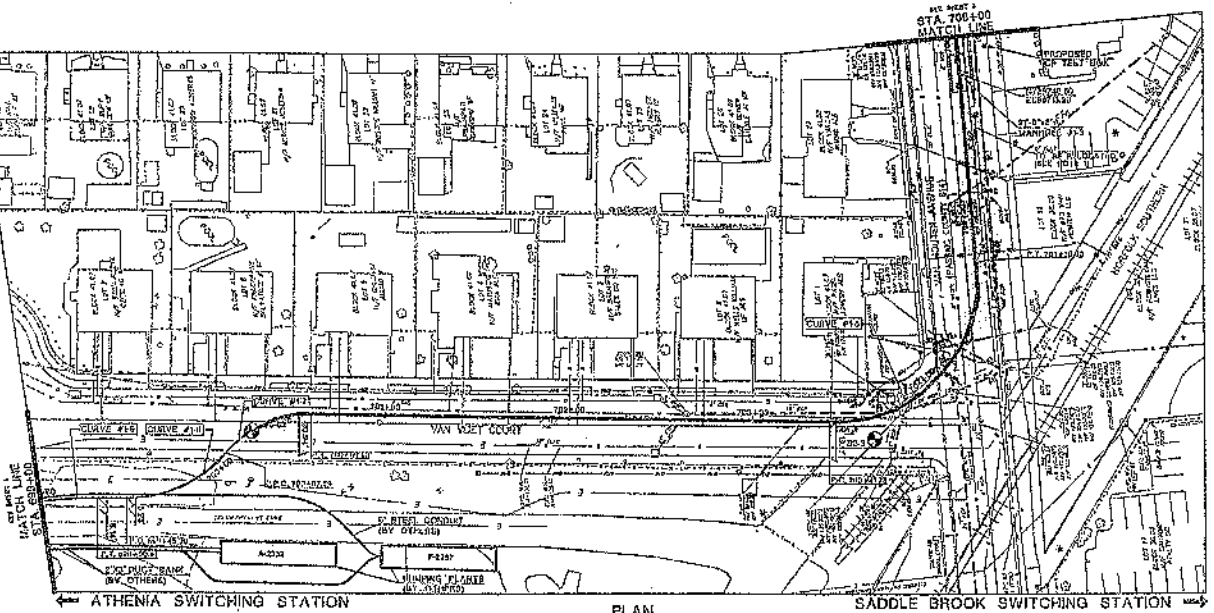

**PLAN**  
 SCALE: 1"=40'

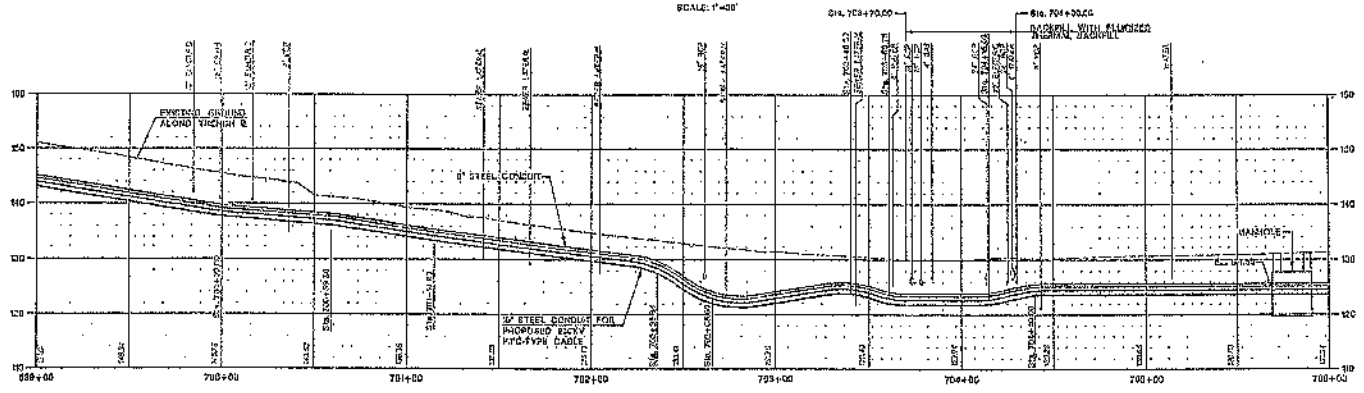

**PROFILE**  
 SCALE: H=20' HORIZONTAL  
 V=10' VERTICAL



**GENERAL NOTES**  
 USE PRINCP OF LATEST REVISION ONLY.  
 DO NOT SCALE - USE DIMENSIONS ONLY.  
 FOR LIST OF REVISIONS REFER TO SEC DRAWING 149.  
 THIS DRAWING IS SHEET NO. 02 OF 02 SHEETS.  
 ANA R. PERAZA



Ana R. Peraza  
 N.J. Professional Engineer  
 Lic. No. 240E0401400

NO	DATE	DESCRIPTION	BY	CHKD	EXTD	APP

PROPOSED 230KV HPFF PIPE-TYPE CABLE  
 ATHENA SWITCHING STATION - SADDLE BROOK SWITCHING STATION (F-2337)  
 PLAN

PUBLIC SERVICE ELECTRIC AND GAS COMPANY  
 ELECTRIC DELIVERY COMPANY-ASSET RELIABILITY, NEWARK, NJ.

DESIGNED BY: J.P. DATE: 7/20/13 CHECKED BY: J.P. SCALE: 1"=20' DRAWN BY: J.P. EXAMINED BY: J.P.

TU-24-C-30038-0 SHEET 2

ALL RIGHTS RESERVED. NO PART OF THIS DOCUMENT MAY BE REPRODUCED OR TRANSMITTED IN ANY FORM OR BY ANY MEANS, ELECTRONIC OR MECHANICAL, WITHOUT PERMISSION IN WRITING FROM THE ENGINEER OR ARCHITECT.

Indicated on: **March 25, 2014**  
 Adopted on: **March 25, 2014**  
 Official Resolution#: **R20140225**

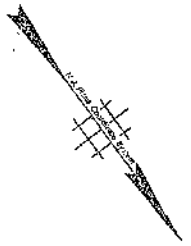
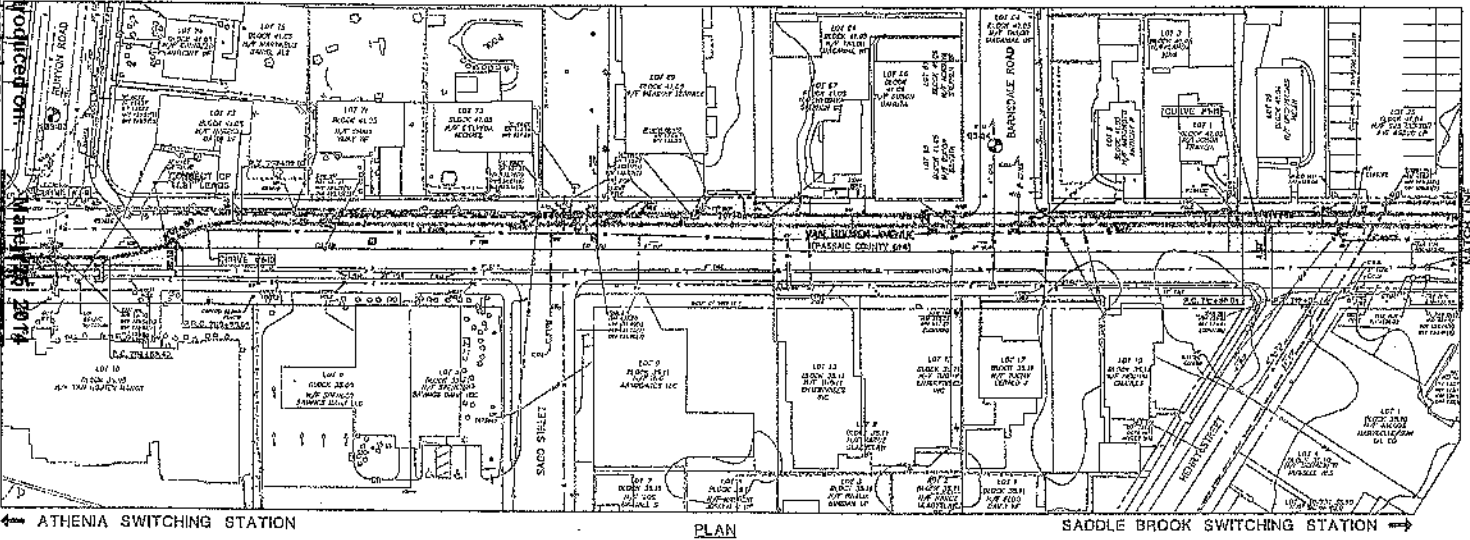

CURVE DATA	
CURVE #13	PC=7650.00
	LC=57.00
TAN=0.00	
PI=7650.00	
PT=7650.00	
M=2071.5023	
CURVE DATA	
CURVE #18	PC=5500.00
	LC=57.00
TAN=0.00	
PI=5500.00	
PT=5500.00	
M=2071.5023	
CURVE DATA	
CURVE #12	PC=7650.00
	LC=57.00
TAN=0.00	
PI=7650.00	
PT=7650.00	
M=2071.5023	

← ATHENIA SWITCHING STATION      PLAN      SADDLE BROOK SWITCHING STATION →  
 SCALE: 1"=20'

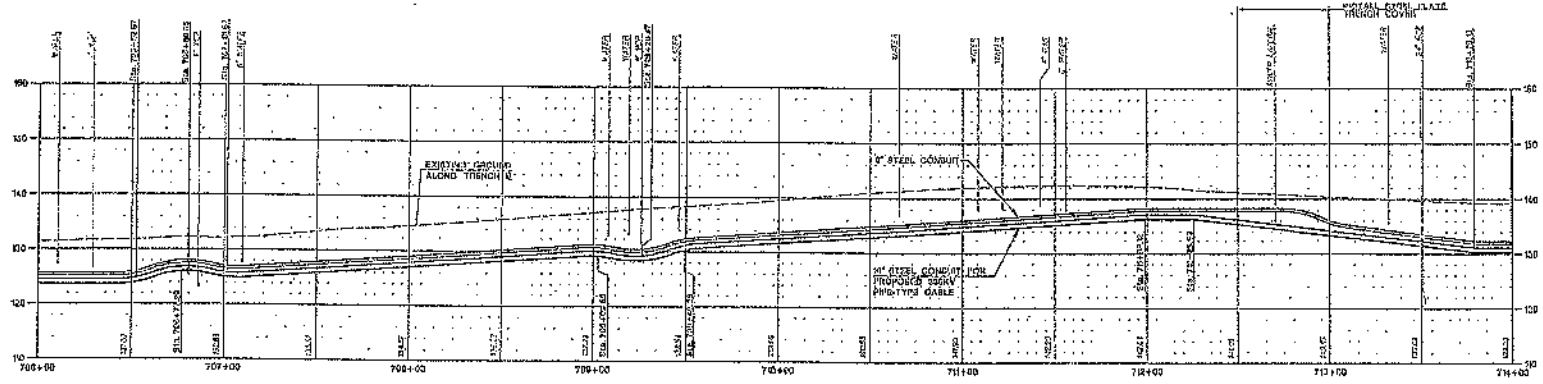

PROFILE  
 SCALE: 1"=60' HORIZONTAL  
 1"=12' VERTICAL



**GENERAL NOTES**  
 SEE NOTES ON SHEET 27 FOR GENERAL NOTES.  
 DO NOT SCALE - USE DIMENSIONS ONLY.  
 FOR LIST OF REFERENCED DRAWINGS SEE DRAWING NO. \_\_\_\_\_  
 THIS DRAWING SUPERSEDES \_\_\_\_\_  
 THIS DRAWING IS SHEET NO. \_\_\_\_\_ OF \_\_\_\_\_ SHEETS.

ANA R. PERAZA  
*Ana R. Peraza*  
 R.E. Professional Engineer  
 Lic. No. 24320481420

**AECOM**  
 300 NORTH ZEEB ROAD, SUITE 200, WASHINGTON, DC 20004  
 TEL: 202-329-4000 FAX: 202-329-4001

NO.	DATE	DESCRIPTION	BY	CHKD	APP'D	NO.

PROPOSED 230KV HPFF  
 PIPE-TYPE CABLE  
 ATHENIA SWITCHING STATION - (F-2337)  
 SADDLE BROOK SWITCHING STATION (F-2337)  
 PLAN

**PSEG**  
 PUBLIC SERVICE ELECTRIC AND GAS COMPANY  
 ELECTRIC DELIVERY COMPANY-ASSET RELIABILITY/REPAIR/CL

DESIGNED BY: \_\_\_\_\_ CHECKED BY: \_\_\_\_\_ SCALE: 1"=20'  
 DATE: 2/23/13 EXAMINED BY: \_\_\_\_\_  
 VBS/EC: \_\_\_\_\_ APPROVED BY: \_\_\_\_\_

TU-24-C-30038-0 SHEET 3

ALL THE DATA AND DIMENSIONS ARE BASED ON THE FIELD SURVEY AND THE DESIGNER'S FIELD NOTES. THE DESIGNER HAS CONDUCTED VISUAL VERIFICATION OF THE DATA AND DIMENSIONS AND HAS FOUND THEM TO BE CORRECT. THE DESIGNER HAS CONDUCTED VISUAL VERIFICATION OF THE DATA AND DIMENSIONS AND HAS FOUND THEM TO BE CORRECT. THE DESIGNER HAS CONDUCTED VISUAL VERIFICATION OF THE DATA AND DIMENSIONS AND HAS FOUND THEM TO BE CORRECT.

Introduced on:  
 Adopted on:  
 Official Resolution#:

March 25, 2014  
 March 25, 2014  
 R20140225

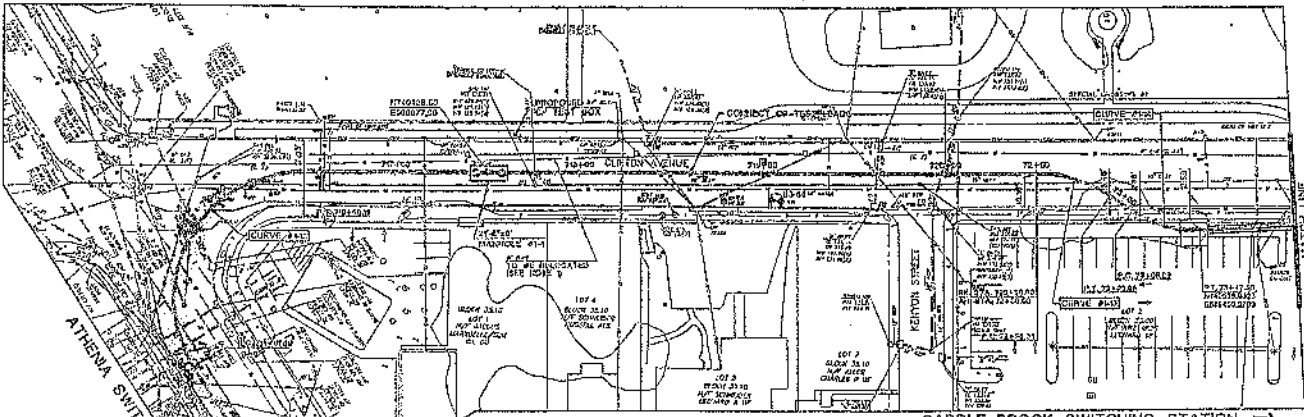

PLAN  
 SCALE: 1"=30'

CURVE DATA	
CURVE #10	
PC= 720.00	
LC= 180.00	
TAN= 0.57735	
Δ = 30.00000°	
PC= 720.00	
PT= 720.00	

CURVE DATA	
CURVE #18	
PC= 720.00	
LC= 90.00	
TAN= 0.57735	
Δ = 30.00000°	
PC= 720.00	
PT= 720.00	

CURVE DATA	
CURVE #1X	
PC= 720.00	
LC= 90.00	
TAN= 0.57735	
Δ = 30.00000°	
PC= 720.00	
PT= 720.00	



NOTES:  
 1. GAS RELOCATION SHALL BE COORDINATED WITH UTILITY OWNERS.

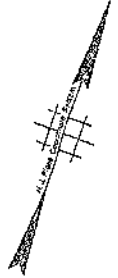

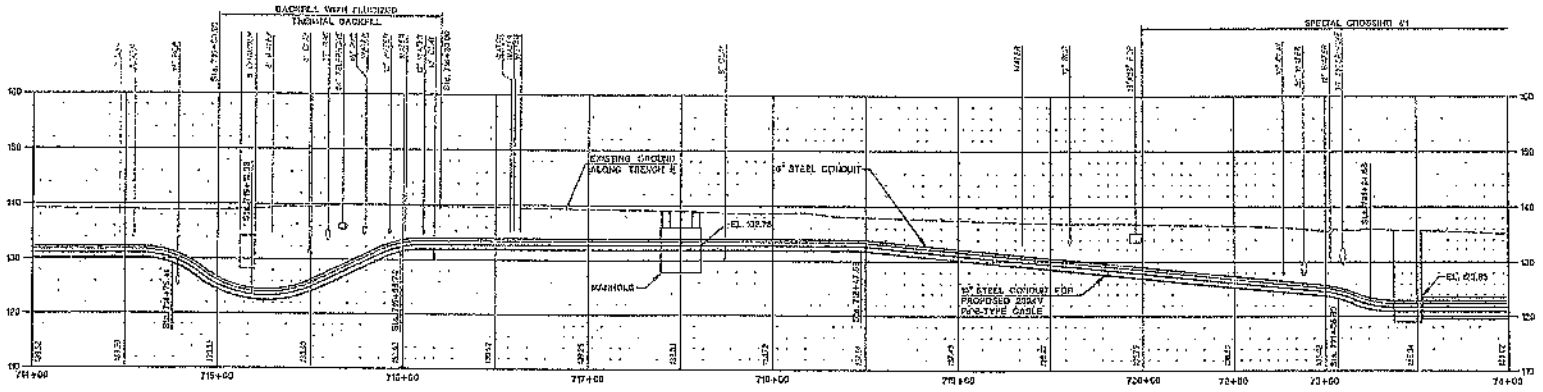
PROFILE  
 SCALE: 1"=20' HORIZONTAL  
 1"=4' VERTICAL



PERSONS SHALL  
 USE PRINTS OF LATEST REVISION ONLY.  
 DO NOT SCALE - USE DIMENSIONS ONLY.  
 FOR LIST OF REFERENCED DRAWINGS SEE  
 DRAWING NO.  
 THIS DRAWING SUPERSEDES:  
 THIS DRAWING IS SHEET NO. 4 OF 4 SHEETS.

ANA R. PERAZA  
*Ana R. Peraza*  
 N.J. Professional Engineer  
 Lic. No. 21GE0401100

**AECOM**  
 10 HANCOCK STREET, SUITE 200, NEWTON, MASSACHUSETTS 02459-1000

NO.	DATE	DESCRIPTION	BY	CHKD	APP'D
1	7/20/11	ISSUED FOR PERMITS			
2	7/20/11	ISSUED FOR PERMITS			
3	7/20/11	ISSUED FOR PERMITS			
4	7/20/11	ISSUED FOR PERMITS			

PROPOSED 230KV HPPF  
 PIPE-TYPE CABLE  
 ATHENA SWITCHING STATION -  
 SADDLE BROOK SWITCHING STATION (P-2337)  
 PLAN CIVIL

**PSEG**  
 PUBLIC SERVICE ELECTRIC AND GAS COMPANY  
 ELECTRIC DELIVERY COMPANY-ASSET RELIABILITY/MAINTENANCE

DESIGNED BY: [ ] CHECKED BY: [ ] SCALE: [ ]  
 DATE: 7/20/11 REVISION: [ ]  
 VDS/GO APPROVED: [ ]

TU-24-C-30038-0 SHEET 4

1. ALL WORK SHALL BE IN ACCORDANCE WITH THE LATEST EDITIONS OF THE NATIONAL ELECTRICAL CODE (NEC) AND THE NATIONAL FIRE ALARM AND SIGNAL CODE (NFPA 72).  
 2. ALL WORK SHALL BE IN ACCORDANCE WITH THE LATEST EDITIONS OF THE NATIONAL ELECTRICAL CODE (NEC) AND THE NATIONAL FIRE ALARM AND SIGNAL CODE (NFPA 72).  
 3. ALL WORK SHALL BE IN ACCORDANCE WITH THE LATEST EDITIONS OF THE NATIONAL ELECTRICAL CODE (NEC) AND THE NATIONAL FIRE ALARM AND SIGNAL CODE (NFPA 72).  
 4. ALL WORK SHALL BE IN ACCORDANCE WITH THE LATEST EDITIONS OF THE NATIONAL ELECTRICAL CODE (NEC) AND THE NATIONAL FIRE ALARM AND SIGNAL CODE (NFPA 72).  
 5. ALL WORK SHALL BE IN ACCORDANCE WITH THE LATEST EDITIONS OF THE NATIONAL ELECTRICAL CODE (NEC) AND THE NATIONAL FIRE ALARM AND SIGNAL CODE (NFPA 72).  
 6. ALL WORK SHALL BE IN ACCORDANCE WITH THE LATEST EDITIONS OF THE NATIONAL ELECTRICAL CODE (NEC) AND THE NATIONAL FIRE ALARM AND SIGNAL CODE (NFPA 72).  
 7. ALL WORK SHALL BE IN ACCORDANCE WITH THE LATEST EDITIONS OF THE NATIONAL ELECTRICAL CODE (NEC) AND THE NATIONAL FIRE ALARM AND SIGNAL CODE (NFPA 72).  
 8. ALL WORK SHALL BE IN ACCORDANCE WITH THE LATEST EDITIONS OF THE NATIONAL ELECTRICAL CODE (NEC) AND THE NATIONAL FIRE ALARM AND SIGNAL CODE (NFPA 72).  
 9. ALL WORK SHALL BE IN ACCORDANCE WITH THE LATEST EDITIONS OF THE NATIONAL ELECTRICAL CODE (NEC) AND THE NATIONAL FIRE ALARM AND SIGNAL CODE (NFPA 72).  
 10. ALL WORK SHALL BE IN ACCORDANCE WITH THE LATEST EDITIONS OF THE NATIONAL ELECTRICAL CODE (NEC) AND THE NATIONAL FIRE ALARM AND SIGNAL CODE (NFPA 72).

# Passaic County Board of Chosen Freeholders

OFFICE OF THE  
PASSAIC COUNTY FREEHOLDERS

Director Pasquale "Pat" Lepore  
Deputy Director Theodore O. Best, Jr.  
John W. Bartlett  
Ronda Casson Cotroneo  
Terry Duffy  
Bruce James  
Hector C. Lora

401 Grand Street  
Paterson, New Jersey 07505  
Tel: 973-881-4402  
Fax: 973-742-3746

Anthony J. De Nova III  
*Administrator*  
William J. Pascrell, III, Esq.  
*County Counsel*  
Louis E. Imhof, III, RMC  
*Clerk Of The Board*



## Public Meeting (Board Meeting)

Date: Mar 25, 2014 - 5:30 PM

Location: County Administration  
220  
401 Grand Street  
Paterson, NJ 07505

Agenda: RESOLUTION APPROVING ROAD OPENING REQUEST FOR KEMSCO CONSTRUCTION AND EQUIPMENT CO., INC. TO OPEN SECTIONS OF MT. PROSPECT AVENUE IN CLIFTON, NEW JERSEY, ALL AS NOTED IN THE RESOLUTION

THIS RESOLUTION WAS REQUESTED BY:

REVIEWED BY:

Anthony J. De Nova III  
COUNTY ADMINISTRATOR

APPROVED AS TO FORM AND LEGALITY:

William J. Pascrell, III, Esq.  
COUNTY COUNSEL

Public Works

COMMITTEE NAME

<b>Official Resolution#</b>		<b>R20140226</b>					
Meeting Date		03/25/2014					
Introduced Date		03/25/2014					
Adopted Date		03/25/2014					
Agenda Item		I-27					
CAF #							
Purchase Req. #							
Result		Adopted					
<b>FREEHOLDER</b>	<b>PRES.</b>	<b>ABS.</b>	<b>MOVE</b>	<b>SEC</b>	<b>AYE</b>	<b>NAY</b>	<b>ABST.</b>
Lepore	✓				✓		
Best Jr	✓		✓		✓		
Bartlett	✓			✓	✓		
Cotroneo	✓				✓		
Duffy	✓				✓		
James	✓				✓		
Lora	✓				✓		

PRES.= present ABS.= absent  
MOVE= moved SEC= seconded  
AYE= yes NAY= no ABST.= abstain

Dated: March 26, 2014

**RESOLUTION APPROVING ROAD OPENING REQUEST FOR  
KEMSCO CONSTRUCTION AND EQUIPMENT CO., INC. TO  
OPEN SECTIONS OF MT. PROSPECT AVENUE IN CLIFTON,  
NEW JERSEY**

**WHEREAS** the Supervisor of Passaic County Roads is in receipt of a request for a Road Opening Permit from Kemsco Construction and Equipment Co., Inc. to open up sections of Mt. Prospect Avenue from Van Houten Avenue to Hemlock Street in Clifton, New Jersey for a distance in excess of 1,000 linear feet for the installation of electric pipe conduit by PSE&G Co.; and

**WHEREAS** the Board of Chosen Freeholders adopted a resolution on the date of September 12, 1991 with respect to requirements concerning road opening permits relative to construction and reconstruction of County roadways; and

**WHEREAS** the Supervisor of Passaic County Roads has reviewed the aforesaid request and recommends that this Board grant permission to Kemsco Construction and Equipment Co., Inc. to open said County road and to issue the necessary number of Road Opening Permits pursuant not only to the terms set forth above, but to the conditions set forth in the County Supervisor's letter dated March 11, 2014 (copy of said letter is attached hereto and made a part hereof); and

**WHEREAS** this application was discussed at the Public Works and Buildings & Grounds Committee meeting of March 10, 2014 and recommended to the full Board for approval;

**NOW THEREFORE BE IT RESOLVED** by the Board of Chosen Freeholders of the County of Passaic that it hereby grants



permission to Kemsco Construction and Equipment Co., Inc. to open up sections of the above-stated County road in Clifton, New Jersey for a distance in excess of 1,000 linear feet in order for PSE&G Co. to install electric pipe conduit pursuant to the terms and conditions set forth above, and subject to the payment of all road opening fees prior to the opening of said roadway and to the adherence to the pavement trench restoration requirements of Passaic County.

March 25, 2014



# County of Passaic

Administration Building Annex  
307 Pennsylvania Avenue • Paterson, New Jersey 07503

RECEIVED

2014 MAR 13 P 2:59

OPERATIONS DIVISION

Jack Nigro  
Passaic County  
Supervisor of Roads

PASSAIC COUNTY  
COUNSEL'S OFFICE

Tel: (973) 881-4500

Fax: (973) 742-2498

Cell: (973) 592-2168

E-mail: jackn@passaiccountynj.org

March 11, 2014

Mr. Michael Glovin, Esq.  
Asst. Passaic County Counsel  
401 Grand Street  
Paterson, New Jersey 07505

Re: Resolution Request-Kemsco Construction and Equipment Co., Inc.  
Mt Prospect Ave, from Van Houten Ave to Hemlock St, Clifton  
**Road Opening in Excess of 1000LF**

Dear Mr. Glovin:

At the March 11, 2014 meeting of the Public Works and Buildings & Grounds Committee a request was heard for Kemsco Construction and Equipment Co., Inc. to open county roadway to install electric pipe conduit for PSE&G total linear footage of 1200lf at Mount Prospect Avenue, from Van Houten Avenue to Hemlock Street in the City of Clifton. The Committee directed that a resolution be made granting the request from Kemsco Construction and Equipment Co., Inc. to install electric pipe conduit in the City of Clifton. A Copy of application for the Right-of-Way entry permit and bond computation form is enclosed

If you should have any question or I can be of additional assistance, please feel free to contact me.

Thank you for your attention and your assistance with this matter.

Very truly yours,

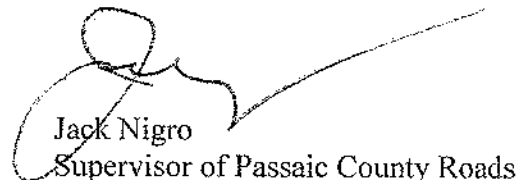
  
Jack Nigro  
Supervisor of Passaic County Roads

JN/gdj

Enclosure

Introduced on: March 25, 2014

Adopted on: Cc: March 26, 2014  
Prepared by: Mr. Michael Duffy, Chair, Public Works and Buildings & Grounds Committee

Official Resolution#: R20140226  
Anthony DeNova, Passaic County Administrator

Steven Edmond, P.E., Passaic County Engineer

COUNTY OF PASSAIC  
DEPARTMENT OF PUBLIC WORKS  
OPERATIONS DIVISION  
307 PENNSYLVANIA AVENUE  
PATERSON, NEW JERSEY 07503

OFFICE - (973) 881-4500

FAX - (973) 742-2498

INSPECTION - (973) 881-4503

Date 3/3/2014

APPLICATION FOR RIGHT-OF-WAY ENTRY PERMIT

Name of Applicant/Contractor: KEMSCO CONSTRUCTION AND EQUIPMENT Co. Inc.

Applicant's Address: 139 HARPER ST  
NEWARK NJ. 07114

Telephone Number: 973-733-2255 Emergency 24 Hour Number: 973-733-2255

Location of Work: MT PROSPECT AVE FROM VAN HOUTEN AVE TO HEMLOCK ST

Municipality: CLIFTON

Purpose of Work: INSTALL ELECTRIC PIPE CONDUIT FOR  
PSE&G

Total Linear Footage: 1200 FT. Excavation Start Date: April 1st 2014

\*\*\* If this project or trench work consists of 1,000 or more linear feet or if this is to be done on a roadway resurfaced within the past five (5) years, permission by the Passaic County Board of Chosen Freeholders will be required prior to the issuance of any permits.

**DRAW A SKETCH BELOW SHOWING THE LOCATION OF THE WORK**  
(SHOW NEAREST CROSS STREET, UTILITY POLE NUMBER, ETC.)

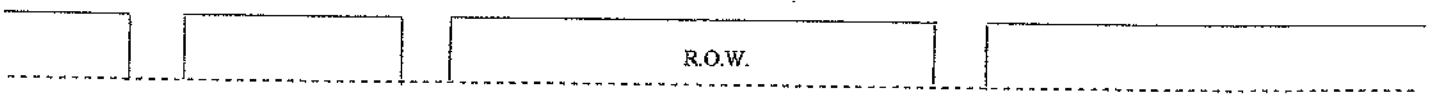
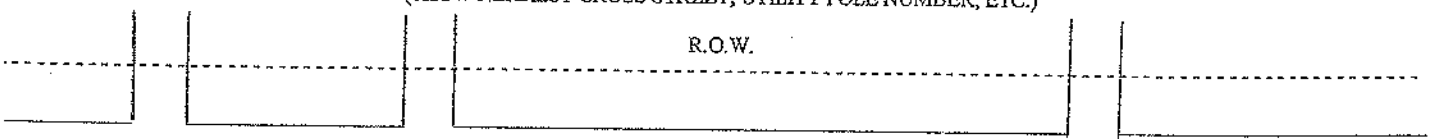

The Applicant agrees to restore the final pavement to a satisfactory condition within and not more than **FOUR MONTHS** from the date of actual opening or sooner if required by the Supervisor of Roads or his authorized representatives.

The Applicant is responsible for the opening for **TWO YEARS** after the final top is placed on the opening and the applicant has notified the Operations Division that the final top has been placed and requested and obtained a final top inspection by a Passaic County Road Inspector.

The Applicant agrees that the opening authorized by this permit, if granted, shall not be made until all conditions and requirements as stated on the reverse side and in the Passaic County Road Opening Resolution have been complied with. (Copy of Resolution available upon request)

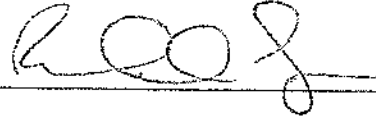
Signature of Applicant 

Permit Number: \_\_\_\_\_

Print Name of Applicant RICHARD EGAN

Permit Issued Date: \_\_\_\_\_

Introduced on: March 25, 2014  
Adopted on: March 25, 2014  
Official Resolution#: R20140226

Approved: Jack Nigro, Supervisor of Roads



COUNTY OF PASSAIC - DEPARTMENT OF PUBLIC WORKS - ENGINEERING DIVISION  
 PERMIT COMPUTATION BREAKDOWN ANALYSIS

NAME OF PROJECT:		PSE&G NE Grid Reliability Project (Revised)				MUNICIPALITY:		Passaic
COUNTY ROADWAY:		Ml. Prospect, Brighton to Hemlock				PASSAIC COUNTY PLANNING BOARD		
Type of Existing Road Last Resurfaced Within 5 Years?	Surface and / or Base Courses:	[ ] - Concrete	[ x ] - Stone	SUBDIVISION / SITE PLAN ->>>> N/A				
TYPE OF WORK		LOCATION OF WORK	QUANTITY	UNIT	NUMBER OF ROAD	OPENINGS ROADSIDE	BONDING RATE	ESTIMATED AMOUNT OF BOND
Access* / Curb Cut				L.F.		N/A		
New Driveway Opening				L.F.		N/A		
Close Existing Opening				L.F.		N/A		
New Curb				L.F.		N/A		
TOTAL			0	L.F.			\$16.00	\$0.00
Conduits (Electric)							NO BOND	NO BOND
Manholes	21"8" Electrical Manhole	1	UNIT	1			NO BOND	NO BOND
Boring		1		1				
Fiber Optic Hand Hold	In Road	1		1				
Pipe	16" steel conduit, 280KV Pipe-type conduit	1240	L.F.	4	0		NO BOND	NO BOND
Conduits (Telephone)							NO BOND	NO BOND
Manholes			UNIT				NO BOND	NO BOND
Pipe			L.F.				NO BOND	NO BOND
Pavement Widening				S.Y.			\$40.00	\$0.00
Trench Restorations:		Conduit	551.1	S.Y.	INCLUDED	INCLUDED		
	MH	26	S.Y.		IN THE	IN THE		
	Boring	1	S.Y.		RESPECTIVE	RESPECTIVE		
	Hand Hold	1	S.Y.		FACILITIES	FACILITIES		
TOTAL			579.1	S.Y.			\$50.00	\$28,955.00
Sanitary Sewer Facilities							NO BOND	NO BOND
Sidewalk (@ - NO FEE)				S.Y.	N/A		NO BOND	NO BOND
Storm Drain Conn. *				UNIT			\$750.00	\$0.00
Manholes			UNIT				\$2,000.00	\$0.00
Inlets			UNIT				\$1,800.00	\$0.00
Pipe			L.F.				\$40.00	\$0.00
Gas Facilities							NO BOND	NO BOND
Manholes			UNIT				NO BOND	NO BOND
Pipe			L.F.				NO BOND	NO BOND
Pipe			L.F.				NO BOND	NO BOND
Pipe			L.F.				NO BOND	NO BOND
Pipe			L.F.				NO BOND	NO BOND
OTHER WORK IN RIGHT-OF-WAY:		Relocate Hydrant		EACH				\$0.00
	Remove Guide:rail			EACH				\$0.00
	Striping (Grind out and replace centerline)			EACH				
TOTALS					7	0		\$28,955.00

\* NOTE 1: THE CONNECTION OF STORM DRAIN FACILITIES TO A PASSAIC COUNTY STORM DRAIN AND THE CONSTRUCTION OR RECONSTRUCTION OF ANY DRIVEWAY, ACCESS DRIVEWAY, OR CURB REPLACEMENT ALSO REQUIRES SEPARATE PERMITS FROM THE PASSAIC COUNTY ENGINEERING DIVISION, PRIOR TO THE ISSUANCE OF THE COMPANION ROAD OPENING OR ROADSIDE OPENING PERMITS.

NOTE 2: THE TOTAL NUMBER OF PERMITS DETERMINED ABOVE DOES NOT INCLUDE THOSE ASSOCIATED WITH THE PROJECT WHICH ARE CONSTRUCTED BY OTHER UTILITY COMPANIES (e.g., GAS, ELECTRIC, TELEPHONE, ETC.), WHO ARE REQUIRED OR ELECT TO INSTALL THEIR SERVICE FACILITIES SEPARATELY. THESE UTILITIES ARE REQUIRED TO OBTAIN THEIR OWN PERMITS FROM THE COUNTY OF PASSAIC.

NOTE 3: WORK NOT BONDABLE UNDER PASSAIC COUNTY REGULATIONS.

Introduced on: **March 25, 2014**  
 Adopted on: **March 25, 2014**  
 Official Resolution#: **R20140226**



**CURVE DATA**

CURVE #14
CHORD
ARC
ANGLE
PI
PC
PY
PT
PTC
R
T
TS
VS
WS
YS
ZS

**SIZES**  
 1. GAS REGULATOR SHALL BE CONCENTRIC  
 2. WITH UTILITY OWNED.

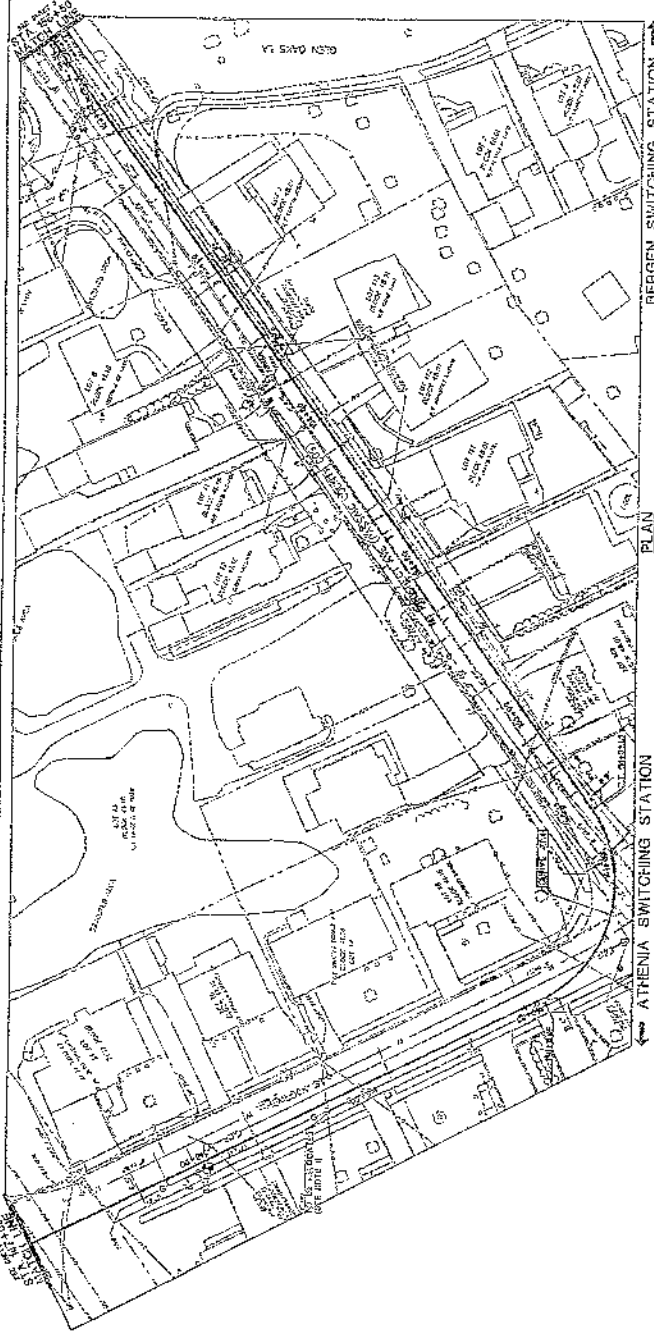

**PLAN**  
 SCALE: 1"=40'

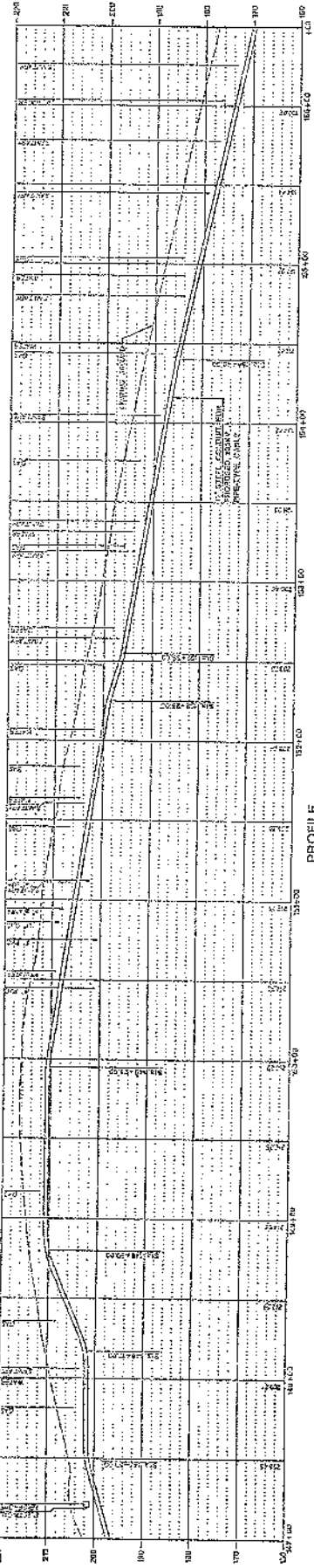

**PROFILE**  
 SCALE: 1"=20' HORIZONTAL  
 1"=10' VERTICAL



**NOTES:**  
 1. SEE PLAN FOR ALL NOTES.  
 2. SEE PLAN FOR ALL NOTES.  
 3. SEE PLAN FOR ALL NOTES.  
 4. SEE PLAN FOR ALL NOTES.  
 5. SEE PLAN FOR ALL NOTES.  
 6. SEE PLAN FOR ALL NOTES.  
 7. SEE PLAN FOR ALL NOTES.  
 8. SEE PLAN FOR ALL NOTES.  
 9. SEE PLAN FOR ALL NOTES.  
 10. SEE PLAN FOR ALL NOTES.

PREPARED BY: ANA D. PERAZZA  
 DATE: 03/25/14  
 PROJECT: ATRENIA SWITCHING STATION TO BERGEN SWITCHING STATION (R-23032)

DESIGNED BY: ANA D. PERAZZA  
 DATE: 03/25/14  
 PROJECT: ATRENIA SWITCHING STATION TO BERGEN SWITCHING STATION (R-23032)

CHECKED BY: ANA D. PERAZZA  
 DATE: 03/25/14  
 PROJECT: ATRENIA SWITCHING STATION TO BERGEN SWITCHING STATION (R-23032)

**AECOM**  
 100 WATERLOO STREET, SUITE 1000  
 NEWTON, MASSACHUSETTS 02459  
 TEL: 617.552.3000  
 FAX: 617.552.3001  
 WWW.AECOM.COM

**PROPOSED 230KV SHFT  
 PIPE-TYPE CABLE  
 ATRENIA SWITCHING STATION TO  
 BERGEN SWITCHING STATION (R-23032)  
 CIVIL**



**PUBLIC SERVICE ELECTRIC AND GAS COMPANY**  
 100 WATERLOO STREET, SUITE 1000  
 NEWTON, MASSACHUSETTS 02459  
 TEL: 617.552.3000  
 FAX: 617.552.3001  
 WWW.PSE&G.COM

DATE	03/25/14
BY	ANA D. PERAZZA
CHECKED BY	ANA D. PERAZZA
DATE	03/25/14
PROJECT	ATRENIA SWITCHING STATION TO BERGEN SWITCHING STATION (R-23032)
SHEET NO.	2
TOTAL SHEETS	2

TU-24-C-30034-B SHEET 2

Introduced on: March 25, 2014  
 Adopted on: March 25, 2014  
 Official Resolution#: R20140226

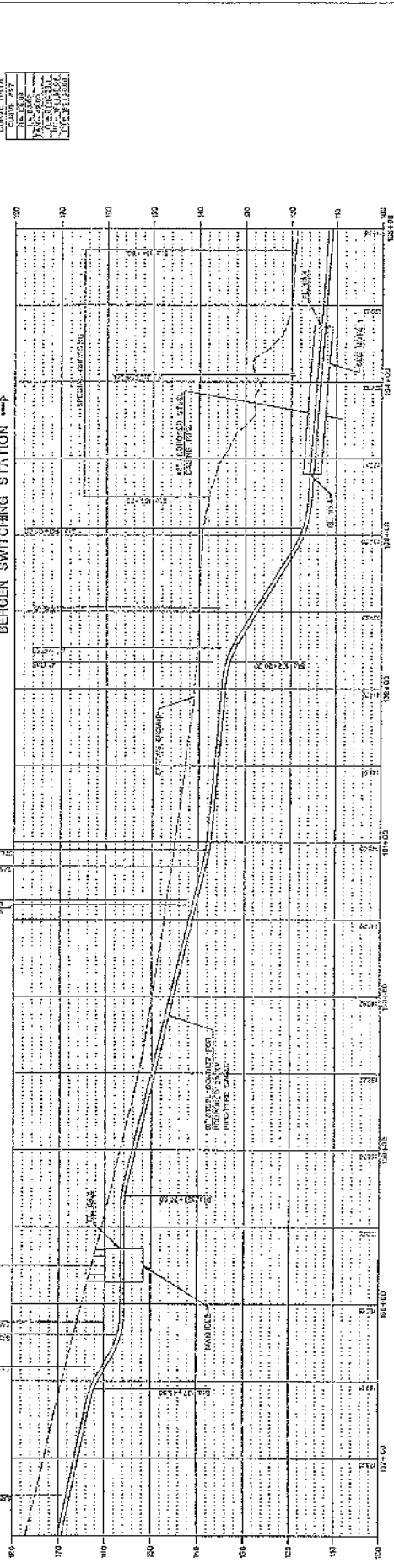
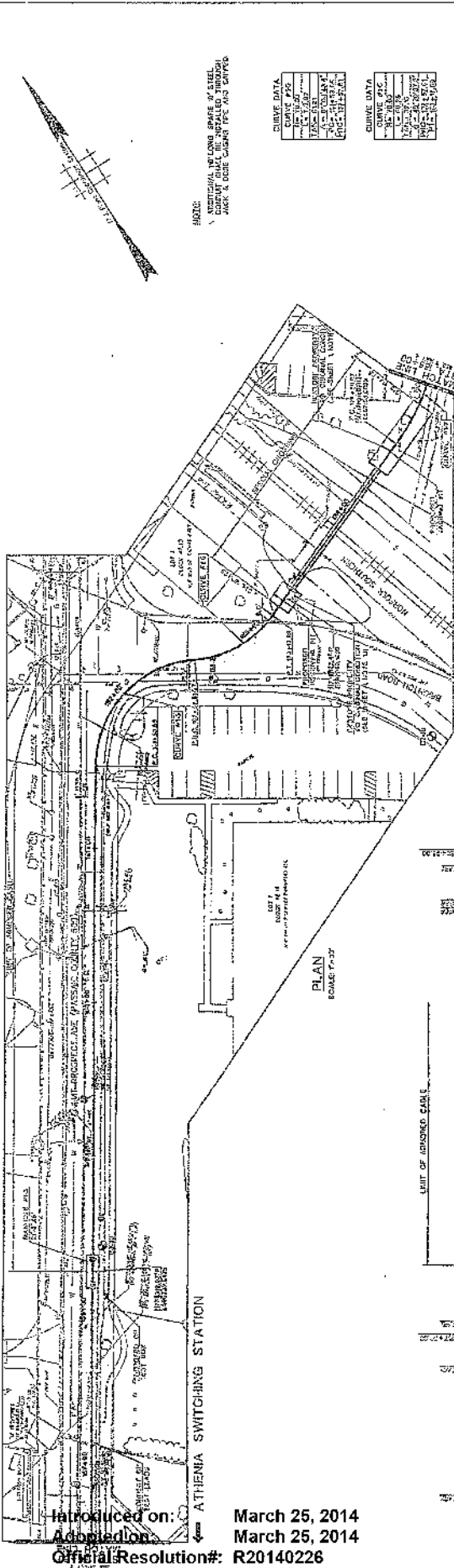

**PROPOSED 230KV HFFF PIPE-TYPE CABLE**  
**ATHENIA SWITCHING STATION TO BERGEN SWITCHING STATION (6-2332)**  
 PLAN

**PS&E**  
 PUBLIC SERVICE ELECTRIC AND GAS COMPANY  
 1200 WEST WASHINGTON AVENUE, NEWARK, NJ 07102  
 (973) 486-1000

**AECOM**  
 100 MARKET STREET, SUITE 2000, NEWARK, NJ 07102  
 (973) 261-1000

**DESIGNED BY:** ANA R. PRINCE  
**CHECKED BY:** *Chris G. Smith*  
**DATE:** 03/25/14

**SCALE:** 1" = 40' HORIZONTAL  
 1" = 4' VERTICAL

**PROFILE**  
 SCALE: 1" = 40' HORIZONTAL  
 1" = 4' VERTICAL

**REVISIONS:**

NO.	DATE	DESCRIPTION	BY	CHKD
1	03/25/14	ISSUED FOR CONSTRUCTION	ANA R. PRINCE	CHRIS G. SMITH

**TU-24-C-30034-0** **SHEET 3**

Introduced on: March 25, 2014  
 Approved on: March 25, 2014  
 Official Resolution#: R20140226

THIS DRAWING IS THE PROPERTY OF PS&E. IT IS TO BE USED ONLY FOR THE PROJECT AND SITE SPECIFICALLY IDENTIFIED HEREON. IT IS NOT TO BE REPRODUCED, COPIED, OR TRANSMITTED IN ANY FORM OR BY ANY MEANS, ELECTRONIC OR MECHANICAL, INCLUDING PHOTOCOPYING, RECORDING, OR BY ANY INFORMATION STORAGE AND RETRIEVAL SYSTEM, WITHOUT THE WRITTEN PERMISSION OF PS&E.

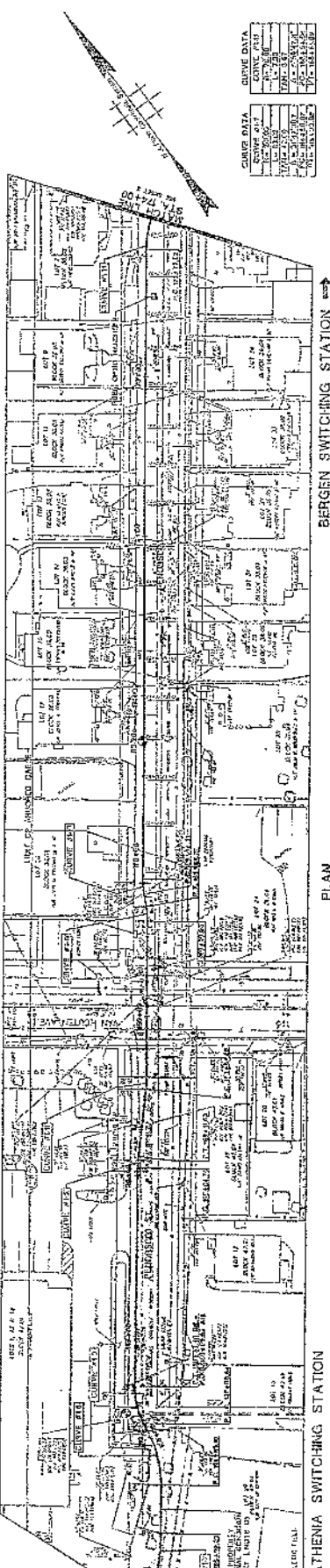

ATHERNA SWITCHING STATION  
PLAN  
SCALE: 1"=40'

<b>CURVE DATA</b>	<b>CURVE DATA</b>	<b>CURVE DATA</b>	<b>CURVE DATA</b>
STATIONING: 10+00 TO 10+50	STATIONING: 10+50 TO 11+00	STATIONING: 11+00 TO 11+50	STATIONING: 11+50 TO 12+00
PI: 10+25	PI: 10+75	PI: 11+25	PI: 11+75
RA: 100'	RA: 100'	RA: 100'	RA: 100'
CHORD BE: 173.64'	CHORD BE: 173.64'	CHORD BE: 173.64'	CHORD BE: 173.64'
CHORD ANG: 90.00°	CHORD ANG: 90.00°	CHORD ANG: 90.00°	CHORD ANG: 90.00°
ARC ANG: 90.00°	ARC ANG: 90.00°	ARC ANG: 90.00°	ARC ANG: 90.00°
PT: 10+00	PT: 10+50	PT: 11+00	PT: 11+50
PT: 10+50	PT: 11+00	PT: 11+50	PT: 12+00

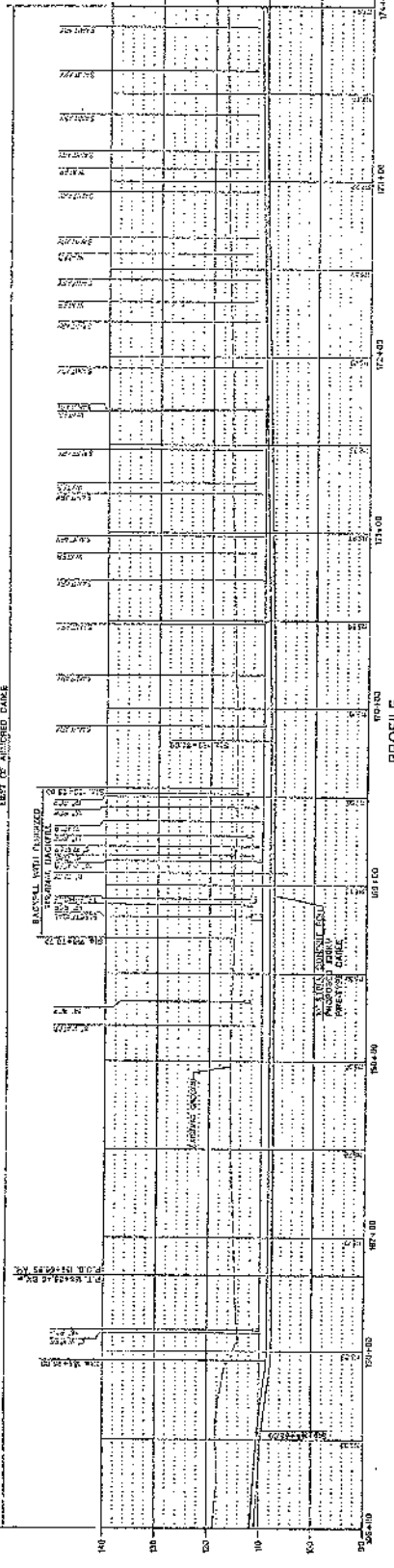

PROFILE  
SCALE: 1"=40' HORIZONTAL  
1"=4' VERTICAL



PROPOSED 23KV 140FF  
PIPE-TYPE CABLE  
ATHERNA SWITCHING STATION TO  
BERGEN SWITCHING STATION (0-2322)  
PLAN

**PSDC**

PUBLIC SERVICE ELECTRIC AND GAS COMPANY  
TELEPHONE DELIVERY COMPANY-ASSET RELIABILITY, NEWARK, NJ

DESIGNED BY: [Name]  
CHECKED BY: [Name]  
DATE: [Date]  
JOB NO.: [Number]

NO.	DATE	REVISION	BY	CHKD	APP'D

ESTABLISHED  
SEE PLAN OF JAMES HANCOCK ST. ETC.  
DO NOT SCALE - USE DIMENSIONS ONLY.  
FOR LIST OF REFERENCE MATERIAL REL.  
DIMENSIONS IN  
THIS DRAWING OR DRAWINGS  
SEE DRAWING TO SHEET NO. 0-2322-1  
ANN. T. FERAZZA  
AECOM  
S. J. Probstmann, Engineer  
Lic. No. 21025064920

TU-24-C-30034-0 SHEET 4

Introduced on March 25, 2014  
Adopted on March 25, 2014  
Official Resolution: R20140226



## COUNTY OF PASSAIC RESOLUTION REQUEST FORM

1. NAME OF REQUESTER & Tel # Engineering

**DESCRIPTION OF RESOLUTION (PLEASE BE SPECIFIC AS POSSIBLE)**

Resolution Approving a Contract Amendment, in the amount of \$1,850.00, issued to Simoff Engineering for Ramapo Plaza Condemnation Analysis.

**CERTIFICATION INFORMATION:**

ATTACH A COPY OF THE REQUISITION FROM EDMONDS

ATTACH A COPY OF A "DETAIL BUDGET ACCOUNT STATUS INCLUDING REQUISITION ITEMS" PAGE FROM EDMONDS

PLEASE NOTE THAT RESOLUTIONS FOR ALL CONTRACT AWARDS AND OTHER EXPENDITURES REQUIRE A REQUISITION. RESOLUTION REQUESTS FOR EXPENDITURES WILL NOT BE CONSIDERED WITHOUT A REQUISITION NUMBER

3. AMOUNT OF EXPENDITURE \$1,850.00

BUDGET ACCOUNT: C-04-55-964-000-902

PURCHASE ORDER # 13-13016

- | 4. COMMITTEE REVIEW:   | <u>DATE</u>    |
|--|----------------|
| <input type="checkbox"/> Administration & Finance                      | _____          |
| <input checked="" type="checkbox"/> Public Works / Buildings & Grounds | <u>3-10-14</u> |
| <input type="checkbox"/> Planning & Economic Development               | _____          |
| <input type="checkbox"/> Health, Human Services & Community Affairs    | _____          |
| <input type="checkbox"/> Law & Public Safety                           | _____          |
| <input type="checkbox"/> Energy  | _____          |
| <input type="checkbox"/> Other Specify: _____                          | _____          |

5. DISTRIBUTION LIST:

Administration  
 Finance  
 Counsel  
 Clerk to Board  
 Procurement  
 Other(s) Specify \_\_\_\_\_



Simoff Engineering Associates, Inc.

Engineers - Transportation Engineering,  
Development and Planning Consultants

2 Shunpike Road  
Madison, NJ 07940

WWW.SIMOFF.COM  
Ph: (973) 966-9000  
Fax: (973) 805-2310

March 6, 2014

Michael Glovin, Esq.  
Assistant County Counsel  
County of Passaic  
Room 214  
401 Grand Street  
Paterson, N.J. 07505-2023

RE: Condemnation Analysis  
Ramapo Plaza Associates  
Paterson Hamburg Turnpike & Valley Road  
Wayne, New Jersey  
Our File No: 13-128

Dear Mr. Glovin:

This letter has been drafted to update our fee proposal. The extra work on the assignment will include preparation time for the hearing on March 12, 2014 and attendance at that hearing. The preparation time will be no more than 4 hours at \$185/Hour and the hearing time that I expect to be 6 hours. Therefore the additional fee will not exceed \$1850.

Sincerely,  
SIMOFF ENGINEERING ASSOCIATES, INC.

Hal Simoff, PE

HS/gd

# Passaic County Board of Chosen Freeholders

OFFICE OF THE  
PASSAIC COUNTY FREEHOLDERS

Director Pasquale "Pat" Lepore  
Deputy Director Theodore O. Best, Jr.  
John W. Bartlett  
Ronda Casson Cotroneo  
Terry Duffy  
Bruce James  
Hector C. Lora

401 Grand Street  
Paterson, New Jersey 07505

Tel: 973-881-4402  
Fax: 973-742-3746

Anthony J. De Nova III

Administrator

William J. Pascrell, III, Esq.

County Counsel

Louis E. Imhof, III, RMC

Clerk Of The Board



## Public Meeting (Board Meeting)

Date: Mar 25, 2014 - 5:30 PM

Location: County Administration  
220  
401 Grand Street  
Paterson, NJ 07505

Agenda: RESOLUTION TO AMEND CONTRACT FOR SIMOFF ENGINEERING ASSOCIATES, LLC AS IT CONCERNS THE PREPARATION OF AN EXPERT TRAFFIC ENGINEERING REPORT RELATING TO A CONDEMNATION HEARING FOR PROPERTY AT 777 HAMBURG TURNPIKE IN WAYNE, NJ FOR THE INTERSECTION IMPROVEMENT PROJECT OF THE PATERSON HAMBURG TURNPIKE & VALLEY ROAD INTERSECTION IMPROVEMENT PROJECT IN WAYNE, NJ, ALL AS NOTED IN THE RESOLUTION

THIS RESOLUTION WAS REQUESTED BY:

REVIEWED BY:

Anthony J. De Nova III  
COUNTY ADMINISTRATOR

APPROVED AS TO FORM AND LEGALITY:

William J. Pascrell, III, Esq.  
COUNTY COUNSEL

Public Works

COMMITTEE NAME

<b>Official Resolution#</b>	<b>R20140227</b>						
Meeting Date	03/25/2014						
Introduced Date	03/25/2014						
Adopted Date	03/25/2014						
Agenda Item	I-28						
CAF #	C-04-55-964-000-902						
Purchase Req. #	PO #13-13016						
Result	Adopted						
<b>FREEHOLDER</b>	<b>PRES.</b>	<b>ABS.</b>	<b>MOVE</b>	<b>SEC</b>	<b>AYE</b>	<b>NAY</b>	<b>ABST.</b>
Lepore	✓				✓		
Best Jr	✓		✓		✓		
Bartlett	✓			✓	✓		
Cotroneo	✓				✓		
Duffy	✓				✓		
James	✓				✓		
Lora	✓				✓		

PRES.= present ABS.= absent  
MOVE= moved SEC= seconded  
AYE= yes NAY= no ABST.= abstain

**RESOLUTION TO AMEND CONTRACT FOR SIMOFF ENGINEERING ASSOCIATES, LLC AS IT CONCERNS THE PREPARATION OF AN EXPERT TRAFFIC ENGINEERING REPORT RELATING TO A CONDEMNATION HEARING FOR PROPERTY AT 777 HAMBURG TURNPIKE IN WAYNE, NJ FOR THE INTERSECTION IMPROVEMENT PROJECT OF THE PATERSON HAMBURG TURNPIKE & VALLEY ROAD INTERSECTION IMPROVEMENT PROJECT IN WAYNE, NJ**

**WHEREAS** a professional engineering consultant services contract was awarded to Simoff Engineering Associates, LLC by Resolution R-2014-746 dated September 24, 2014 as it concerns the preparation of an expert traffic engineering report with regard to a condemnation hearing for property at 777 Hamburg Turnpike in Wayne, New Jersey secured by the County of Passaic for the Intersection Improvement Project of the Paterson Hamburg Turnpike & Valley Road Intersection in the amount of \$5,000.00; and

**WHEREAS** after preparation and issuance of the report it became obvious that Hal Simoff, the principal of the firm, would need to offer expert testimony and opinion during the hearing; and

**WHEREAS** Mr. Simoff has submitted a proposal dated March 6, 2014 for the additional time needed for preparation and actual testimony on an hourly basis not to exceed \$1,850.00 (a copy of proposal attached hereto and made a part hereof); and

**WHEREAS** the matter was reviewed by the Freeholder Committee for Public Works and Buildings & Grounds at their

meeting on March 10, 2014 and is recommended for approval by the entire Board; and

**WHEREAS** a certification is attached hereto and made a part hereof indicating the availability of funds for this expenditure.

**NOW THEREFORE BE IT RESOLVED** by the Board of Chosen Freeholders of the County of Passaic that it hereby authorizes an amendment to the original professional engineering consulting services contract for Simoff Engineering Associates, LLC for the additional work outside the original scope of the original project on an hourly basis up to \$1,850.00 as set forth above and in its March 6, 2014 proposal attached hereto.

**BE IT FURTHER RESOLVED** that the Director and Clerk to the Board are authorized by sign an amendment on behalf of the County of Passaic.

March 25, 2014

# Passaic County Board of Chosen Freeholders

OFFICE OF THE  
PASSAIC COUNTY FREEHOLDERS

Director Pasquale "Pat" Lepore  
Deputy Director Theodore O. Best, Jr.  
John W. Bartlett  
Ronda Casson Cotroneo  
Terry Duffy  
Bruce James  
Hector C. Lora

401 Grand Street  
Paterson, New Jersey 07505

Tel: 973-881-4402  
Fax: 973-742-3746

Anthony J. De Nova III

Administrator

William J. Pascrell, III, Esq.

County Counsel

Louis E. Imhof, III, RMC

Clerk Of The Board



## Public Meeting (Board Meeting)

Date: Mar 25, 2014 - 5:30 PM

Location: County Administration  
220  
401 Grand Street  
Paterson, NJ 07505

Agenda: RESOLUTION APPROVING ROAD OPENING REQUEST FOR KEMSCO CONSTRUCTION AND EQUIPMENT CO., INC. TO OPEN SECTIONS OF CLIFTON AVENUE IN CLIFTON, NEW JERSEY, ALL AS NOTED IN THE RESOLUTION

THIS RESOLUTION WAS REQUESTED BY:

REVIEWED BY:

Anthony J. De Nova III  
COUNTY ADMINISTRATOR

APPROVED AS TO FORM AND LEGALITY:

William J. Pascrell, III, Esq.  
COUNTY COUNSEL

Public Works

COMMITTEE NAME

<b>Official Resolution#</b>		<b>R20140228</b>						
Meeting Date		03/25/2014						
Introduced Date		03/25/2014						
Adopted Date		03/25/2014						
Agenda Item		I-29						
CAF #								
Purchase Req. #								
Result		Adopted						
<b>FREEHOLDER</b>	<b>PRES.</b>	<b>ABS.</b>	<b>MOVE</b>	<b>SEC</b>	<b>AYE</b>	<b>NAY</b>	<b>ABST.</b>	
Lepore	✓				✓			
Best Jr	✓		✓		✓			
Bartlett	✓			✓	✓			
Cotroneo	✓				✓			
Duffy	✓				✓			
James	✓				✓			
Lora	✓				✓			

PRES.= present ABS.= absent  
MOVE= moved SEC= seconded  
AYE= yes NAY= no ABST.= abstain

Dated: March 26, 2014

**RESOLUTION APPROVING ROAD OPENING REQUEST FOR  
KEMSCO CONSTRUCTION AND EQUIPMENT CO., INC. TO  
OPEN SECTIONS OF CLIFTON AVENUE IN CLIFTON, NEW  
JERSEY**

**WHEREAS** the Supervisor of Passaic County Roads is in receipt of a request for a Road Opening Permit from Kemsco Construction and Equipment Co., Inc. to open up sections of Clifton Avenue from Van Houten Avenue to Lexington Avenue in Clifton, New Jersey for a distance in excess of 1,000 linear feet for the installation of electric pipe conduit by PSE&G Co.; and

**WHEREAS** the Board of Chosen Freeholders adopted a resolution on the date of September 12, 1991 with respect to requirements concerning road opening permits relative to construction and reconstruction of County roadways; and

**WHEREAS** the Supervisor of Passaic County Roads has reviewed the aforesaid request and recommends that this Board grant permission to Kemsco Construction and Equipment Co., Inc. to open said County road and to issue the necessary number of Road Opening Permits pursuant not only to the terms set forth above, but to the conditions set forth in the County Supervisor's letter dated March 11, 2014 (copy of said letter is attached hereto and made a part hereof); and

**WHEREAS** this application was discussed at the Public Works and Buildings & Grounds Committee meeting of March 10, 2014 and recommended to the full Board for approval;

**NOW THEREFORE BE IT RESOLVED** by the Board of Chosen Freeholders of the County of Passaic that it hereby grants

permission to Kemsco Construction and Equipment Co., Inc. to open up sections of the above-stated County road in Clifton, New Jersey for a distance in excess of 1,000 linear feet in order for PSE&G Co. to install electric pipe conduit pursuant to the terms and conditions set forth above, and subject to the payment of all road opening fees prior to the opening of said roadway and to the adherence to the pavement trench restoration requirements of Passaic County.

March 25, 2014





# County of Passaic

Administration Building Annex  
307 Pennsylvania Avenue • Paterson, New Jersey 07503

RECEIVED

2014 MAR 13 P 2:59  
OPERATIONS DIVISION

Jack Nigro  
Passaic County  
Supervisor of Roads

PASSAIC COUNTY  
COUNSEL OFFICE  
Tel: (973) 881-4500  
Fax: (973) 742-7498  
Cell: (973) 592-2168

March 11, 2014

E-mail: jackn@passaiccountynj.org

Mr. Michael Glovin, Esq.  
Asst. Passaic County Counsel  
401 Grand Street  
Paterson, New Jersey 07505

Re: Resolution Request-Kemsco Construction and Equipment Co., Inc.  
Clifton Avenue, From Van Houten Avenue to Lexington  
Avenue, Clifton  
**Road Opening in Excess of 1000LF**  
**Road Resurfaced within five (5) years**

Dear Mr. Glovin:

At the March 11, 2014 meeting of the Public Works and Buildings & Grounds Committee a request was heard for Kemsco Construction and Equipment Co., Inc. to open county roadway to install electric pipe conduit for PSE&G total linear footage of 8200lf at Clifton Avenue, from Van Houten Avenue to Lexington Avenue in the City of Clifton. This section of Clifton Avenue was last resurfaced on October 15, 2010. The Committee directed that a resolution be made granting the request from Kemsco Construction and Equipment Co., Inc. to install electric pipe conduit in the City of Clifton. A Copy of application for the Right-of-Way entry permit and bond computation form is enclosed. If you should have any question or I can be of additional assistance, please feel free to contact me.

Thank you for your attention and your assistance with this matter.

Very truly yours,

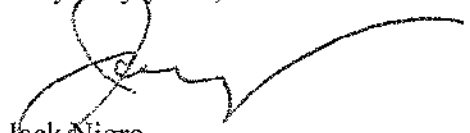
  
Jack Nigro  
Supervisor of Passaic County Roads

JN/gdj

Enclosure

Introduced on: March 25, 2014  
Adopted on: March 26, 2014  
Official Resolution#: R20140228  
Cc: Anthony DeNova, Passaic County Administrator  
Steven Edmond, P.E., Passaic County Engineer  
March 26, 2014 Duffy, Chair, Public Works and Buildings & Grounds Committee

COUNTY OF PASSAIC  
DEPARTMENT OF PUBLIC WORKS  
OPERATIONS DIVISION  
307 PENNSYLVANIA AVENUE  
PATERSON, NEW JERSEY 07503

OFFICE - (973) 881-4500

FAX - (973) 742-2498

INSPECTION - (973) 881-4503

Date 3/3/2014

APPLICATION FOR RIGHT-OF-WAY ENTRY PERMIT

Name of Applicant/Contractor: KEMSCO CONSTRUCTION AND EQUIPMENT CO. INC.

Applicant's Address: 139 HARPER ST  
NEWARK NJ 07114

Telephone Number: 973-733-2255 Emergency 24 Hour Number: 973-733-2255

Location of Work: CLIFTON AVE FROM JAN HOUTEN AVE TO LEXINGTON AVE.

Municipality: CLIFTON

Purpose of Work: INSTALL ELECTRIC PIPE CONDUIT  
FOR PSE&G.

Total Linear Footage: 8200 Excavation Start Date: APRIL 1ST 2014

\*\*\* If this project or trench work consists of 1,000 or more linear feet or if this is to be done on a roadway resurfaced within the past five (5) years, permission by the Passaic County Board of Chosen Freeholders will be required prior to the issuance of any permits.

**DRAW A SKETCH BELOW SHOWING THE LOCATION OF THE WORK**  
(SHOW NEAREST CROSS STREET, UTILITY POLE NUMBER, ETC.)

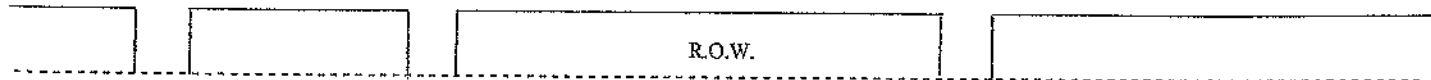
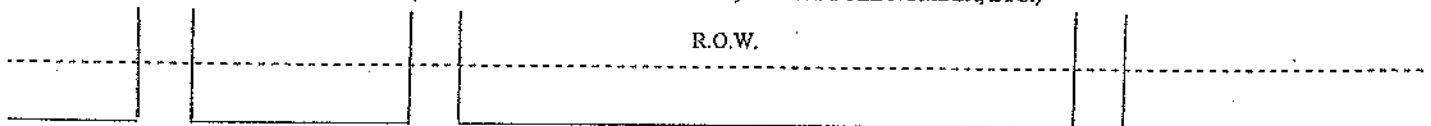

The Applicant agrees to restore the final pavement to a satisfactory condition within and not more than **FOUR MONTHS** from the date of actual opening or sooner if required by the Supervisor of Roads or his authorized representatives.

The Applicant is responsible for the opening for **TWO YEARS** after the final top is placed on the opening and the applicant has notified the Operations Division that the final top has been placed and requested and obtained a final top inspection by a Passaic County Road Inspector.

The Applicant agrees that the opening authorized by this permit, if granted, shall not be made until all conditions and requirements as stated on the reverse side and in the Passaic County Road Opening Resolution have been complied with. (Copy of Resolution available upon request)

Signature of Applicant 

Permit Number: \_\_\_\_\_

Print Name of Applicant RICHARD EVANS

Permit Issued Date: \_\_\_\_\_

Introduced on: March 25, 2014  
Adopted on: March 25, 2014  
Official Resolution#: R20140228

Approved: \_\_\_\_\_

Jack Nigro, Supervisor of Roads



COUNTY OF PASSAIC - DEPARTMENT OF PUBLIC WORKS - ENGINEERING DIVISION  
 PERMIT COMPUTATION BREAKDOWN ANALYSIS

NAME OF PROJECT:		PSE&G NE Grid Reliability Project					
COUNTY ROADWAY:		Clifton Ave, Van Houten to Lexington			MUNICIPALITY:		Clifton
Type of Existing Road Surface and/or Base Course:		[ x ] - Concrete [ ] - Stone			PASSAIC COUNTY PLANNING BOARD SUBDIVISION / SITE PLAN -->>>> N/A NUMBER (IF APPLICABLE)		
Road Last Resurfaced Within 5 Years?		Yes [Van Houten to Paulison, Gotty to Lexington 2010]					
TYPE OF WORK	LOCATION OF WORK	QUANTITY	UNIT	NUMBER OF ROAD	OPENINGS ROADSIDE	BONDING RATE	ESTIMATED AMOUNT OF BOND
Access* / Curb Cut							
New Driveway Opening			L.F.		N/A		
Close Existing Opening			L.F.		N/A		
New Curb			L.F.		N/A		
TOTAL		0	L.F.	0	0	\$16.00	\$0.00
Conduits (Electric)						NO BOND	NO BOND
Manholes	21'8"x8' Electrical Manhole	4	UNIT	4		NO BOND	NO BOND
Fiber Optic Hand Holds	Under Road	6	Unit	6			
Test Boxes	Under Sidewalk	3	Unit		3		
Pipe under Ground	10" steel conduit, 280KV Pipe-type conduit	233	L.F.		1		
Pipe under Road	10" steel conduit, 280KV Pipe-type conduit	8560	L.F.	29	0	NO BOND	NO BOND
Borings		17		17		NO BOND	NO BOND
Pavement Widening			S.Y.			\$40.00	\$0.00
Trench Restorations:	Conduit	3903.60	S.Y.	INCLUDED	INCLUDED		
	Hand Holds	6	S.Y.	IN THE	IN THE		
	Manholes	104		IN THE	IN THE		
	Test Boxes	3	S.Y.	RESPECTIVE	RESPECTIVE		
	Gas	677.1	S.Y.	FACILITIES	FACILITIES		
	Borings	17	S.Y.				
TOTAL		4710.7	S.Y.	0	0	\$50.00	\$235,535.00
Sanitary Sewer Facilities						NO BOND	NO BOND
Sidewalk (@ - NO FEE)	at Test Boxes	3	S.Y.	N/A	3	NO BOND	NO BOND
Storm Drain Conn. *			UNIT			\$750.00	\$0.00
Manholes			UNIT			\$2,000.00	\$0.00
Inlets			UNIT			\$1,800.00	\$0.00
Pipe			L.F.			\$40.00	\$0.00
Gas Facilities						NO BOND	NO BOND
Manholes			UNIT			NO BOND	NO BOND
Pipe	Relocate Gas Main	1375	L.F.	4		NO BOND	NO BOND
Pipe			L.F.			NO BOND	NO BOND
Pipe			L.F.			NO BOND	NO BOND
Pipe			L.F.			NO BOND	NO BOND
OTHER WORK IN RIGHT-OF-WAY:	Relocate Hydrant		EACH				\$0.00
	Remove Guiderail		EACH				\$0.00
	Striping (Grind out and replace centerline)		EACH				
TOTALS				60	7		\$235,535.00

\* NOTE 1: THE CONNECTION OF STORM DRAIN FACILITIES TO A PASSAIC COUNTY STORM DRAIN AND THE CONSTRUCTION OR RECONSTRUCTION OF ANY DRIVEWAY, ACCESS DRIVEWAY, OR CURB REPLACEMENT ALSO REQUIRES SEPARATE PERMITS FROM THE PASSAIC COUNTY ENGINEERING DIVISION, PRIOR TO THE ISSUANCE OF THE COMPANION ROAD OPENING OR ROADSIDE OPENING PERMITS.

NOTE 2: THE TOTAL NUMBER OF PERMITS DETERMINED ABOVE DOES NOT INCLUDE THOSE ASSOCIATED WITH THE PROJECT WHICH ARE CONSTRUCTED BY OTHER UTILITY COMPANIES (e.g., GAS, ELECTRIC, TELEPHONE, ETC.), WHO ARE REQUIRED OR ELECT TO INSTALL THEIR SERVICE FACILITIES SEPARATELY. THESE UTILITIES ARE REQUIRED TO OBTAIN THEIR OWN SEPARATE PERMITS FROM THE COUNTY OF PASSAIC.  
 Introduced on: March 25, 2014  
 Adopted on: March 25, 2014  
 Official Resolution#: R20140228





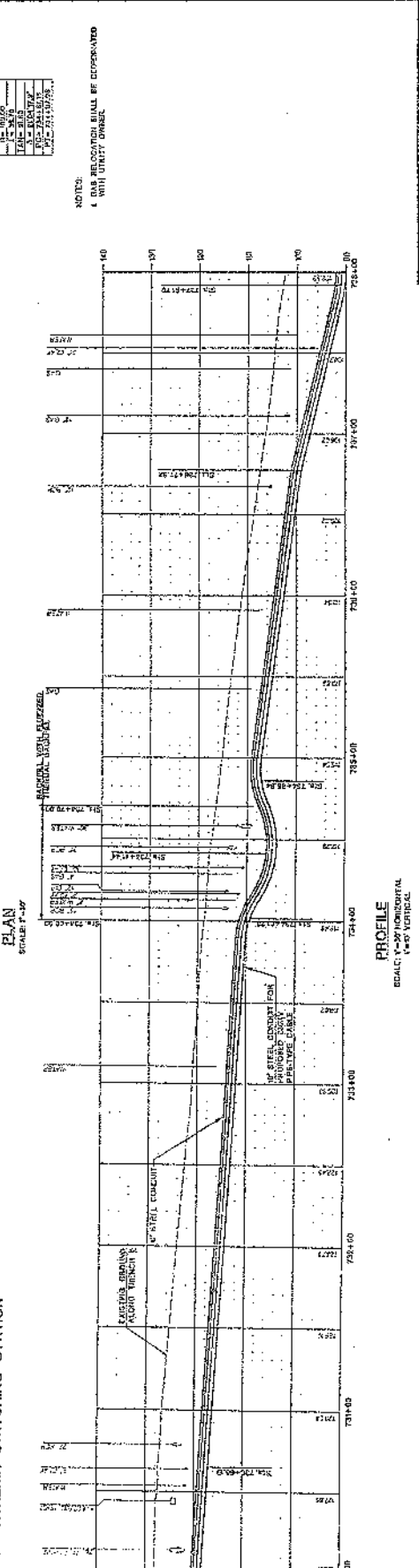
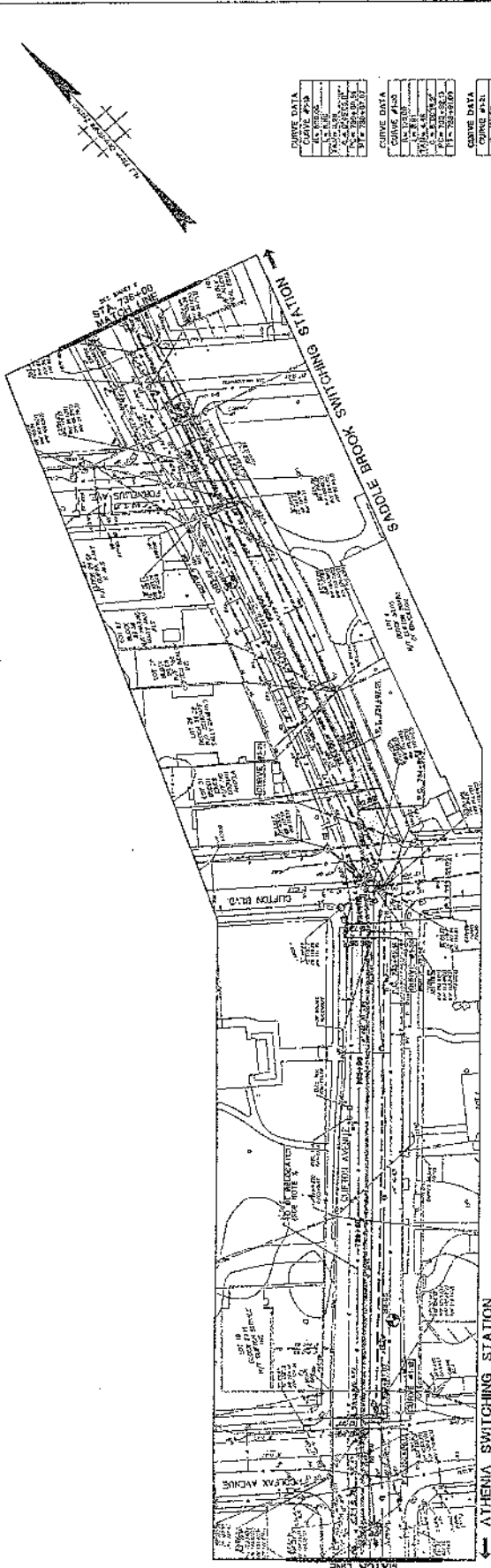

PROPOSED 238KV HPFF  
 PIPE-TYPE CABLE  
 ATHENA SWITCHING STATION -  
 SADDLE BROOK SWITCHING STATION (F-2337)  
 LABEL

**PS&G**  
 PUBLIC SERVICE ELECTRIC AND GAS COMPANY  
 DIRECTOR OF ENGINEERING - RELIABILITY/OPERATIONS

TU-24-C-30036-0 SHEET 6

NO.	DATE	DESCRIPTION	BY	CHKD	APP'D
1	07/13/13	ISSUED FOR CONSTRUCTION	ANA T. POTANZA		
2	07/13/13	REVISIONS			

**GENERAL NOTES:**  
 USE PRINTING OF LATEST REVISION ONLY.  
 DO NOT SCALE - USE DIMENSIONS SHOWN.  
 SEE LIST OF REVISIONS DRAWING SET.  
 THIS DRAWING IS PART OF A PROJECT.  
 SEE DRAWING SET FOR ALL PROJECT DETAILS.

ANA T. POTANZA  
 R.E. Professional Engineer  
 Lic. No. 24004484800



Introduced on: March 25, 2014  
 Adopted on: March 25, 2014  
 Official Resolution#: R20140228

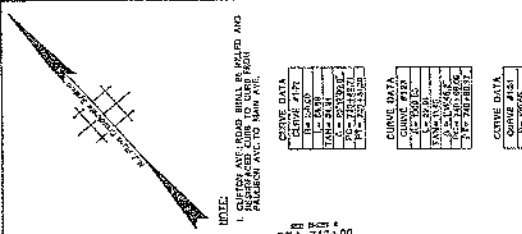

NOTE:  
 1. CURVE DATA SHALL BE PLACED AND  
 2. PALETTES A.C. TO DATA ARE

CURVE DATA

STATION	14+24.00
PC	14+24.00
PT	14+24.00
PI	14+24.00
EA	14+24.00
EB	14+24.00
EC	14+24.00
ED	14+24.00
EE	14+24.00
EF	14+24.00
EG	14+24.00
EH	14+24.00
EI	14+24.00
EJ	14+24.00
EK	14+24.00
EL	14+24.00
EM	14+24.00
EN	14+24.00
EO	14+24.00
EP	14+24.00
EQ	14+24.00
ER	14+24.00
ES	14+24.00
ET	14+24.00
EU	14+24.00
EV	14+24.00
EW	14+24.00
EX	14+24.00
EY	14+24.00
EZ	14+24.00

CURVE DATA

STATION	14+24.00
PC	14+24.00
PT	14+24.00
PI	14+24.00
EA	14+24.00
EB	14+24.00
EC	14+24.00
ED	14+24.00
EE	14+24.00
EF	14+24.00
EG	14+24.00
EH	14+24.00
EI	14+24.00
EJ	14+24.00
EK	14+24.00
EL	14+24.00
EM	14+24.00
EN	14+24.00
EO	14+24.00
EP	14+24.00
EQ	14+24.00
ER	14+24.00
ES	14+24.00
ET	14+24.00
EU	14+24.00
EV	14+24.00
EW	14+24.00
EX	14+24.00
EY	14+24.00
EZ	14+24.00

CURVE DATA

STATION	14+24.00
PC	14+24.00
PT	14+24.00
PI	14+24.00
EA	14+24.00
EB	14+24.00
EC	14+24.00
ED	14+24.00
EE	14+24.00
EF	14+24.00
EG	14+24.00
EH	14+24.00
EI	14+24.00
EJ	14+24.00
EK	14+24.00
EL	14+24.00
EM	14+24.00
EN	14+24.00
EO	14+24.00
EP	14+24.00
EQ	14+24.00
ER	14+24.00
ES	14+24.00
ET	14+24.00
EU	14+24.00
EV	14+24.00
EW	14+24.00
EX	14+24.00
EY	14+24.00
EZ	14+24.00

CURVE DATA

STATION	14+24.00
PC	14+24.00
PT	14+24.00
PI	14+24.00
EA	14+24.00
EB	14+24.00
EC	14+24.00
ED	14+24.00
EE	14+24.00
EF	14+24.00
EG	14+24.00
EH	14+24.00
EI	14+24.00
EJ	14+24.00
EK	14+24.00
EL	14+24.00
EM	14+24.00
EN	14+24.00
EO	14+24.00
EP	14+24.00
EQ	14+24.00
ER	14+24.00
ES	14+24.00
ET	14+24.00
EU	14+24.00
EV	14+24.00
EW	14+24.00
EX	14+24.00
EY	14+24.00
EZ	14+24.00

CURVE DATA

STATION	14+24.00
PC	14+24.00
PT	14+24.00
PI	14+24.00
EA	14+24.00
EB	14+24.00
EC	14+24.00
ED	14+24.00
EE	14+24.00
EF	14+24.00
EG	14+24.00
EH	14+24.00
EI	14+24.00
EJ	14+24.00
EK	14+24.00
EL	14+24.00
EM	14+24.00
EN	14+24.00
EO	14+24.00
EP	14+24.00
EQ	14+24.00
ER	14+24.00
ES	14+24.00
ET	14+24.00
EU	14+24.00
EV	14+24.00
EW	14+24.00
EX	14+24.00
EY	14+24.00
EZ	14+24.00

CURVE DATA

STATION	14+24.00
PC	14+24.00
PT	14+24.00
PI	14+24.00
EA	14+24.00
EB	14+24.00
EC	14+24.00
ED	14+24.00
EE	14+24.00
EF	14+24.00
EG	14+24.00
EH	14+24.00
EI	14+24.00
EJ	14+24.00
EK	14+24.00
EL	14+24.00
EM	14+24.00
EN	14+24.00
EO	14+24.00
EP	14+24.00
EQ	14+24.00
ER	14+24.00
ES	14+24.00
ET	14+24.00
EU	14+24.00
EV	14+24.00
EW	14+24.00
EX	14+24.00
EY	14+24.00
EZ	14+24.00

CURVE DATA

STATION	14+24.00
PC	14+24.00
PT	14+24.00
PI	14+24.00
EA	14+24.00
EB	14+24.00
EC	14+24.00
ED	14+24.00
EE	14+24.00
EF	14+24.00
EG	14+24.00
EH	14+24.00
EI	14+24.00
EJ	14+24.00
EK	14+24.00
EL	14+24.00
EM	14+24.00
EN	14+24.00
EO	14+24.00
EP	14+24.00
EQ	14+24.00
ER	14+24.00
ES	14+24.00
ET	14+24.00
EU	14+24.00
EV	14+24.00
EW	14+24.00
EX	14+24.00
EY	14+24.00
EZ	14+24.00

PROPOSED 230KV HREF  
 PIPE-TYPE CABLE  
 ATHENA SWITCHING STATION -  
 SADDLE BROOK SWITCHING STATION IF-23371  
 PLAN

**PS&G**

PUBLIC SERVICE ELECTRIC AND GAS COMPANY  
 ELECTRIC DELIVERE COMPANY-REST RELIABILITY-KENNELS

DESIGNED BY: [ ] CHECKED BY: [ ] DRAWN BY: [ ]  
 DATE: 7/20/13 EXAMINED BY: [ ]  
 SCALE: 1"=100'

TU-24-C-30038-0 SHEET 7

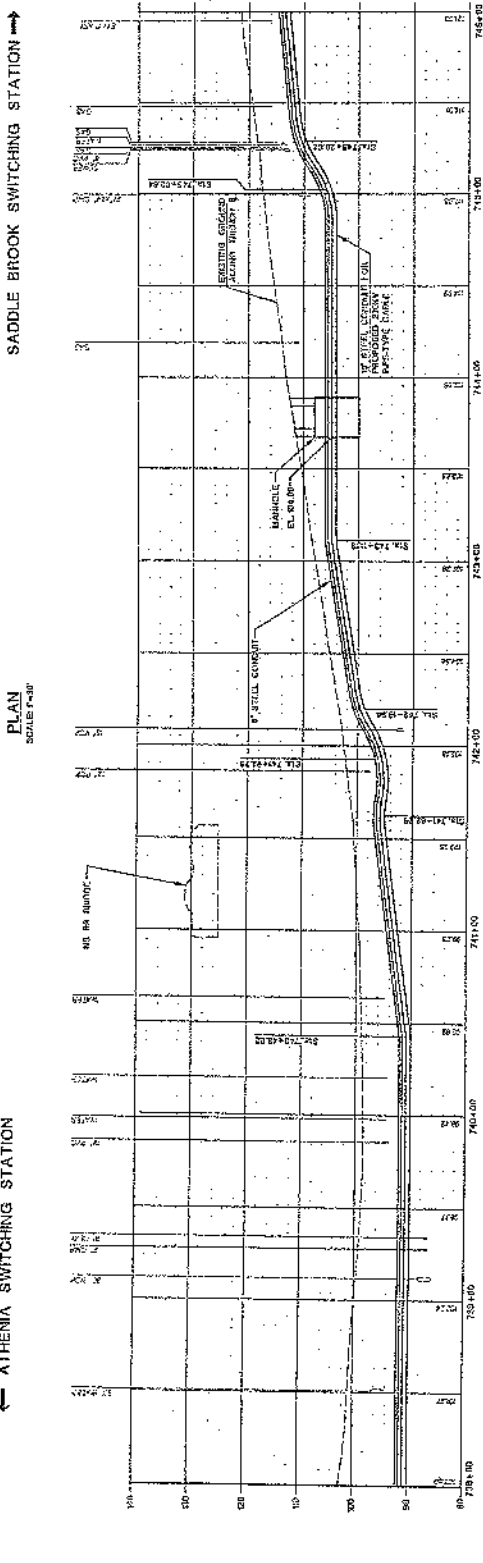
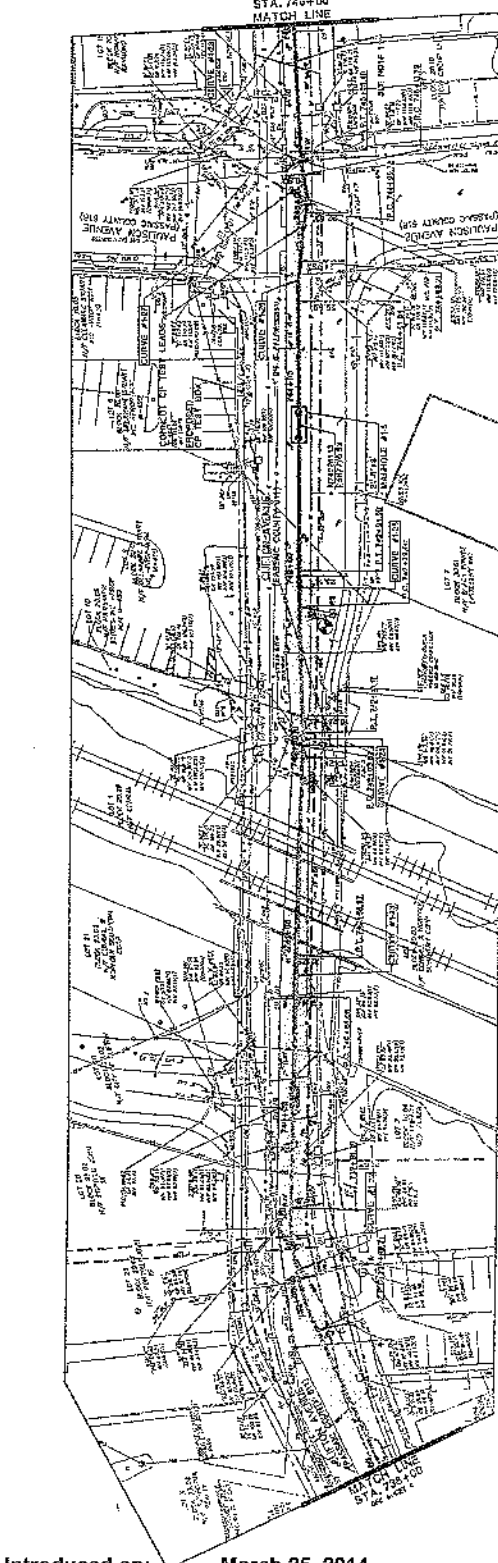

Introduced on: March 25, 2014  
 Adopted on: March 25, 2014  
 Official Resolution#: R20140228

ANN. P. PERAZA  
 7/16/13

*Ann. P. Peraza*

A.E.C.O.M.  
 PROFESSIONAL ENGINEER  
 LICENSE NO. 246686800

REVISIONS

NO.	DATE	DESCRIPTION	BY	APPROVED BY



Small text at the bottom of the page, likely containing project details or contact information.









CURVE DATA	
CHURCH ST	100'
4th ST	100'
5th ST	100'
6th ST	100'
7th ST	100'
8th ST	100'
9th ST	100'
10th ST	100'
11th ST	100'
12th ST	100'
13th ST	100'
14th ST	100'
15th ST	100'
16th ST	100'
17th ST	100'
18th ST	100'
19th ST	100'
20th ST	100'
21st ST	100'
22nd ST	100'
23rd ST	100'
24th ST	100'
25th ST	100'
26th ST	100'
27th ST	100'
28th ST	100'
29th ST	100'
30th ST	100'
31st ST	100'
32nd ST	100'
33rd ST	100'
34th ST	100'
35th ST	100'
36th ST	100'
37th ST	100'
38th ST	100'
39th ST	100'
40th ST	100'
41st ST	100'
42nd ST	100'
43rd ST	100'
44th ST	100'
45th ST	100'
46th ST	100'
47th ST	100'
48th ST	100'
49th ST	100'
50th ST	100'
51st ST	100'
52nd ST	100'
53rd ST	100'
54th ST	100'
55th ST	100'
56th ST	100'
57th ST	100'
58th ST	100'
59th ST	100'
60th ST	100'
61st ST	100'
62nd ST	100'
63rd ST	100'
64th ST	100'
65th ST	100'
66th ST	100'
67th ST	100'
68th ST	100'
69th ST	100'
70th ST	100'
71st ST	100'
72nd ST	100'
73rd ST	100'
74th ST	100'
75th ST	100'
76th ST	100'
77th ST	100'
78th ST	100'
79th ST	100'
80th ST	100'
81st ST	100'
82nd ST	100'
83rd ST	100'
84th ST	100'
85th ST	100'
86th ST	100'
87th ST	100'
88th ST	100'
89th ST	100'
90th ST	100'
91st ST	100'
92nd ST	100'
93rd ST	100'
94th ST	100'
95th ST	100'
96th ST	100'
97th ST	100'
98th ST	100'
99th ST	100'
100th ST	100'

NOTE:  
 1. ALL CURVE DATA SHALL BE CHECKED AND  
 2. ALL CURVE DATA SHALL BE CHECKED AND  
 3. ALL CURVE DATA SHALL BE CHECKED AND

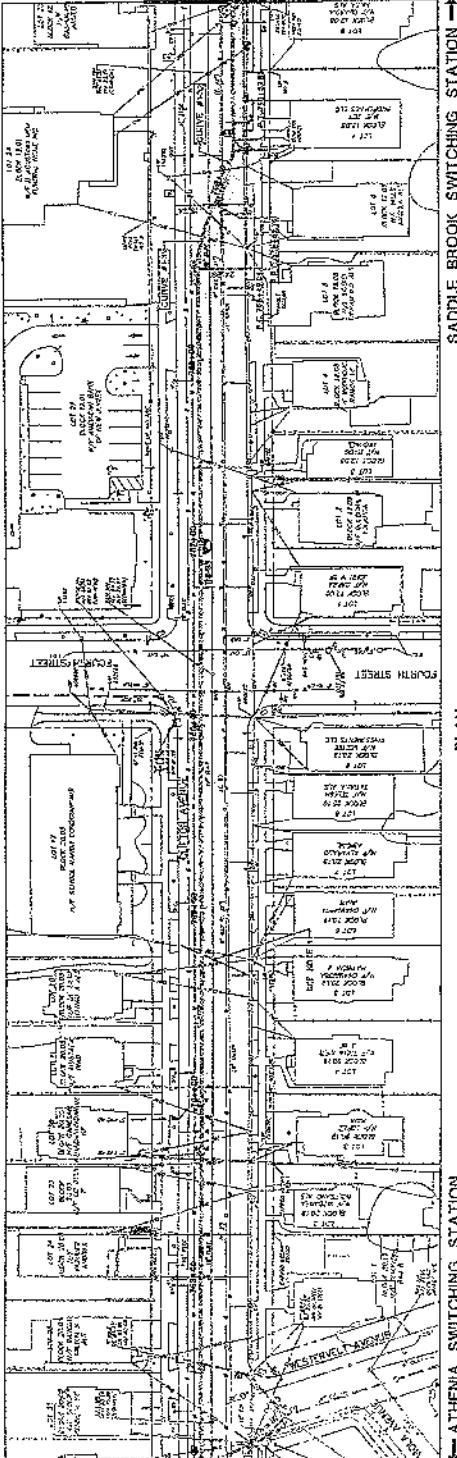

PLAN  
 SCALE: 1"=40'

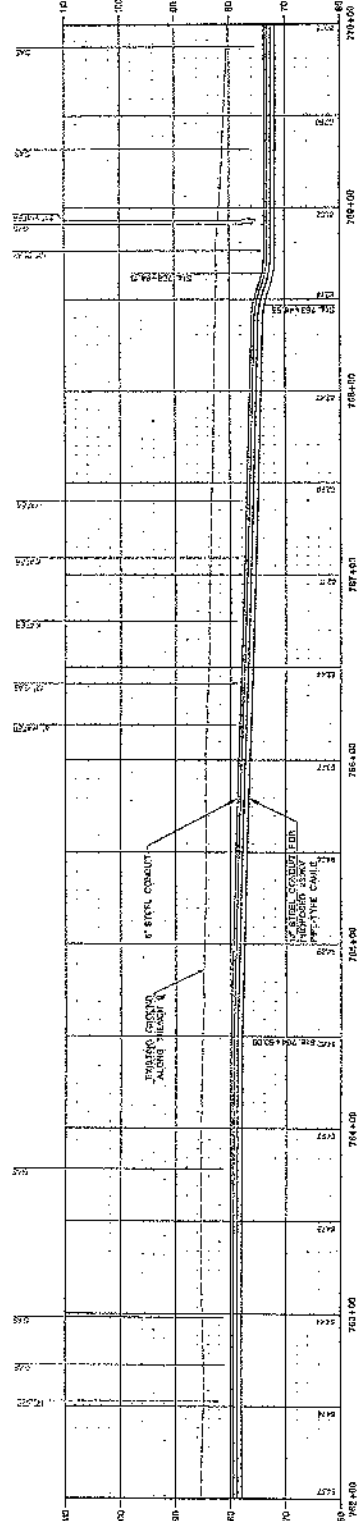

PROFILE  
 SCALE: 1"=20' HORIZONTAL  
 1"=4' VERTICAL



PROPOSED 20KV UPFE  
 OVERHEAD CABLE  
 ATHENS SWITCHING STATION (0-2337)  
 SADDLE BROOK SWITCHING STATION  
 PLAN

**PSE&C**  
 PUBLIC SERVICE ELECTRIC AND GAS COMPANY  
 ELECTRIC DELIVERY DEPARTMENT BELLEVILLE, NEWARK, NJ

DATE: 01/20/14  
 SCALE: 1"=40'  
 DRAWN BY: JSC  
 CHECKED BY: JSC  
 APPROVED BY: JSC

TU-24-C-30038-0 SHEET 10

GENERAL NOTES:  
 1. USE PRINTED LATEST NUMBER ONLY.  
 2. DO NOT SCALE - BUT DIMENSIONS SHALL BE  
 TAKEN FROM THE LIST OF DIMENSIONS OR FROM THE  
 DRAWING.  
 3. THIS DRAWING IS SUBJECT TO ALL ORDINANCES,  
 REGULATIONS AND RULES OF THE BOARD OF  
 PUBLIC UTILITIES COMMISSIONERS.

ANA R. PERAZZA  
 N.J. Professional Engineer  
 Lic. No. 3400000100



Introduced on: March 25, 2014  
 Adopted on: March 25, 2014  
 Official Resolution#: R20140228



CURVE DATA	
STATION	770+00
LENGTH	100.00
PI	770+00
PC	770+00
PB	770+00
PT	770+00
STATION	770+00
LENGTH	100.00
PI	770+00
PC	770+00
PB	770+00
PT	770+00

NOTE:  
 1. CLIPTON AVE. ROAD SHALL BE MAILED AND  
 PAVED TO THE CENTERLINE FROM  
 PAVEMENT TO THE MAIL AVENUE

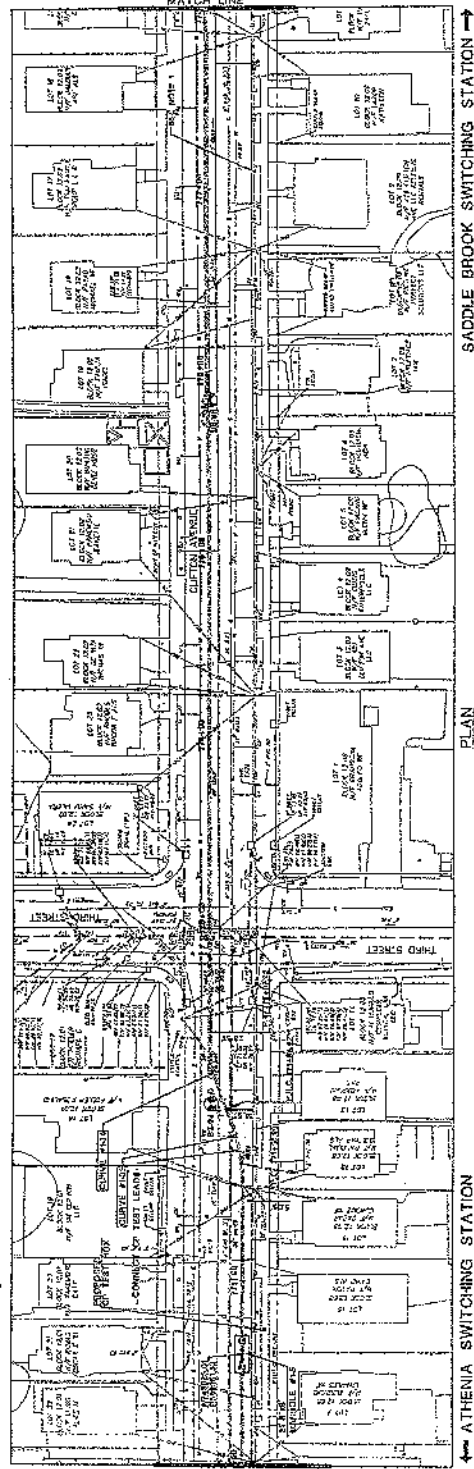

PLAN  
 SCALE 1"=80'

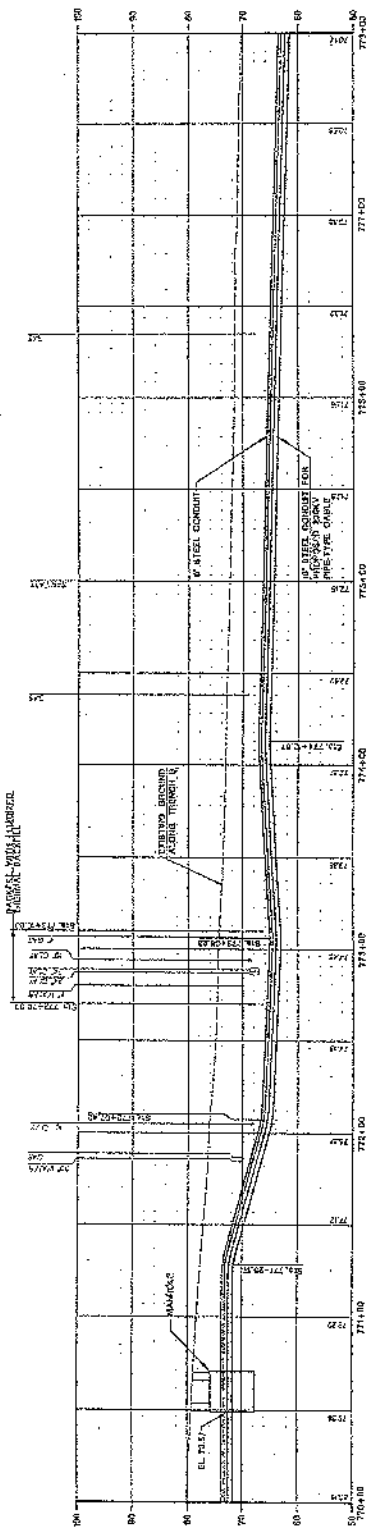

PROFILE  
 SCALE 1"=10' HORIZONTAL  
 1"=1' VERTICAL



PROPOSED 230KV R/HFF  
 ATHERNIA SWITCHING STATION -  
 SADDLE BROOK SWITCHING STATION (F-2337)  
 PLAN

**PSE&C**  
 PUBLIC SERVICE ELECTRIC AND GAS COMPANY  
 ELECTRIC DELIVERY COMPANY-ASSET RELIABILITY, INCORPORATED

DESIGNED BY: STAFF  
 DRAWN BY: STAFF  
 CHECKED BY: STAFF  
 APPROVED BY: STAFF

TU-24-C-30038-0 SHEET 11

GENERAL NOTES  
 USE PRINTS OF LATEST REVISION ONLY.  
 FOR ANY COPY - USE DIMENSIONS ONLY.  
 FOR LIST OF REVISIONS DRAWING SEE  
 THIS DRAWING'S ATTACHED  
 THIS DRAWING IS SHEET NO. 11 OF 11 SHEETS.  
 ANA R. PERAZA

*Ana R. Peraza*  
 Lic. No. 2400040140

**AECOM**  
 100 WATERGATE ROAD, ROCKAWAY, NJ 07866  
 ENGINEERING DIVISION

NO.	DATE	REVISION

Introduced on: March 25, 2014  
 Adopted on: March 25, 2014  
 Official Resolution#: R20140228











# Passaic County Board of Chosen Freeholders

OFFICE OF THE  
PASSAIC COUNTY FREEHOLDERS

Director Pasquale "Pat" Lepore  
Deputy Director Theodore O. Best, Jr.  
John W. Bartlett  
Ronda Casson Cotroneo  
Terry Duffy  
Bruce James  
Hector C. Lora

401 Grand Street  
Paterson, New Jersey 07505

Tel: 973-881-4402  
Fax: 973-742-3746

Anthony J. De Nova III

Administrator

William J. Pascrell, III, Esq.

County Counsel

Louis E. Imhof, III, RMC

Clerk Of The Board



## Public Meeting (Board Meeting)

Date: Mar 25, 2014 - 5:30 PM

Location: County Administration  
220  
401 Grand Street  
Paterson, NJ 07505

Agenda: RESOLUTION TO AWARD CONTRACT TO MONARCH ELECTRIC FOR ELECTRICAL SUPPLIES AND EQUIPMENT PURCHASED FOR PASSAIC COUNTY BUILDINGS, ALL AS NOTED IN THE RESOLUTION

THIS RESOLUTION WAS REQUESTED BY:

REVIEWED BY:

Anthony J. De Nova III  
COUNTY ADMINISTRATOR

APPROVED AS TO FORM AND LEGALITY:

William J. Pascrell, III, Esq.  
COUNTY COUNSEL

Public Works

COMMITTEE NAME

<b>Official Resolution#</b>	<b>R20140229</b>						
Meeting Date	03/25/2014						
Introduced Date	03/25/2014						
Adopted Date	03/25/2014						
Agenda Item	I-30						
CAF #	4-01-20-112-001-207						
Purchase Req. #	R4-01750; R4-01821; R4-01952; R4-02051						
Result	Adopted						
<b>FREEHOLDER</b>	<b>PRES.</b>	<b>ABS.</b>	<b>MOVE</b>	<b>SEC</b>	<b>AYE</b>	<b>NAY</b>	<b>ABST.</b>
Lepore	✓				✓		
Best Jr	✓		✓		✓		
Bartlett	✓			✓	✓		
Cotroneo	✓				✓		
Duffy	✓				✓		
James	✓				✓		
Lora	✓				✓		

PRES.= present ABS.= absent  
MOVE= moved SEC= seconded  
AYE= yes NAY= no ABST.= abstain

Res-Pg: 1.30-2

**RESOLUTION TO AWARD CONTRACT TO MONARCH  
ELECTRIC FOR ELECTRICAL SUPPLIES AND EQUIPMENT  
PURCHASED FOR PASSAIC COUNTY BUILDINGS**

**WHEREAS** the Passaic County Superintendent of Buildings & Grounds recently reported that he had solicited needed electrical supplies for Passaic County buildings from Monarch Electric of West Caldwell, NJ in the amount of \$883.21; and

**WHEREAS** after the purchase of these supplies it was discovered that said Monarch Electric had received contracts for the year that brought the purchase of these supplies over the monetary threshold established under the New Jersey Pay to Play Law (N.J.S.A. 19:44A-20.3 et seq.); and

**WHEREAS** the said Superintendent is requesting Board action to ensure that it can pay said Monarch Electric for the supplies and equipment that have already been received and utilized; and

**WHEREAS** the said Board by Resolution R-06-97 dated February 14, 2006 established a policy of only awarding contracts in excess of the monetary threshold set forth under the Pay to Play Law only under a fair and open process; and

**WHEREAS** the Board is desirous of making an exception to that policy in this case in order to have this vendor paid for the supplies and equipment purchased by the Passaic County Buildings & Grounds Department; and

**WHEREAS** the Committee for Public Works and Buildings & Grounds reviewed this matter at its March 10, 2014 meeting and is recommending approval by the entire Board; and

**WHEREAS** a certification is attached hereto that indicates the availability of funds for said expenditure.

Chosen Freeholders of the County of Passaic that it hereby authorizes an award of contract to Monarch Electric of West Caldwell, New Jersey in the amount of \$883.21 to pay for electrical supplies and equipment purchased for various County buildings in conformity with the attached request; and

**BE IT FURTHER RESOLVED** that this contract is being awarded as an exception to the policy of the Board as set forth in its Resolution R-06-97 dated February 14, 2006 because of the special circumstances of this situation and the policy of the Board as set forth in this Resolution shall remain in full force and effect; and

**BE IT FURTHER RESOLVED** that the Director and Clerk of the said Board are hereby authorized to execute any necessary agreement on behalf of the County of Passaic.

March 25, 2014

CERTIFICATION OF AVAILABLE FUNDS

THIS IS TO CERTIFY THAT FUNDS ARE AVAILABLE AS FOLLOWS:

AMOUNT: \$833.21

APPROPRIATION: 4-01-20-112-001-207

PURPOSE: To award a contract to Monarch Electric for Electrical Supplies and Equipment purchased for Passaic County buildings.

  
Michael Katz, County Treasurer

DATED: February 25, 2014

**DATE:** March 14, 2014

**TO:** Michael Glovin, County Counsel

**FROM:** Jack Nigro, Superintendent  
Buildings & Grounds



**SUBJECT: RESOLUTION FOR FUNDS**

*Please prepare a resolution for Monarch Electric, in the amount of \$883.21 for electrical materials for use in various County Buildings as discussed at the Public Works Meeting on March 10, 2014.*

*Note: Resolution is needed because Monarch is over the aggregate.*

Thank you.

Attachment(s)

**FAXED**

### COUNTY OF PASSAIC RESOLUTION REQUEST FORM

1. NAME OF REQUESTER: *Jack Nigro*  
Telephone #: 973/881-4425

DESCRIPTION OF RESOLUTION

Request Resolution for Monarch Electric for electrical materials -- they are over the aggregate.

2. CERTIFICATION INFORMATION:

BUDGET ACCOUNT #4-01-20-112-001-207

PLEASE NOTE THAT RESOLUTIONS FOR ALL CONTRACT AWARDS AND OTHER EXPENDITURES REQUIRE A REQUISITION. RESOLUTION REQUESTS FOR EXPENDITURES WILL NOT BE CONSIDERED WITHOUT A REQUISITION NUMBER

3. AMOUNT OF EXPENDITURE: \$883.21

REQUISITION #'s: R4-01750 - \$228.57, R4-01821 - \$167.06, R4-01952 - \$57.70, R4-02051 - \$429.88

4. COMMITTEE REVIEW:

DATE

- Administration & Finance \_\_\_\_\_
- Public Works / Buildings & Grounds \_\_\_\_\_
- Planning & Economic Development \_\_\_\_\_
- Health, Human Services & Community Affairs \_\_\_\_\_
- Law & Public Safety \_\_\_\_\_
- Energy \_\_\_\_\_
- Other Specify: \_\_\_\_\_

5. DISTRIBUTION LIST:

- Administration
  - Finance
  - Counsel
  - Clerk to Board
  - Procurement
- Specify: \_\_\_\_\_

CO OF PASSAIC, PUBLIC BLDGS  
(Q) 973-881-4425  
317 PENNSYLVANIA AVENUE  
PATERSON, NJ 07503

REQUISITION Res-Pg:1.30-7	
NO.	R4-01750

SHIP TO	COUNTY OF PASSAIC BLDGS&GRNDS DEPT 317 PENNSYLVANIA AVENUE PATERSON, NJ 07503
VENDOR	VENDOR #: 03547 MONARCH ELECTRIC COMPANY ONE DODGE DRIVE WEST CALDWELL, NJ 07006 <i>fax 973 808 0209</i>

ORDER DATE: 02/24/14  
DELIVERY DATE:  
STATE CONTRACT:  
F.O.B. TERMS:

QTY/UNIT	DESCRIPTION	ACCOUNT NO.	UNIT PRICE	TOTAL COST
1.00/EA	12/2 ALUM. MC LITE - \$414.64/ M FT	4-01-20-112-001-207	207.3200	207.32
10.00/EA	CCHOTP218 2-1/2D SW BOX W/EAR	4-01-20-112-001-207	1.6669	16.67
10.00/EA	MULB 11227 1G SW RING PC	4-01-20-112-001-207	0.4584	4.58
	AS PER QUOTE 1052922-00			
	NOTE: FOR 30 KING ROAD			
			TOTAL	228.57

*2/24/14* **D**

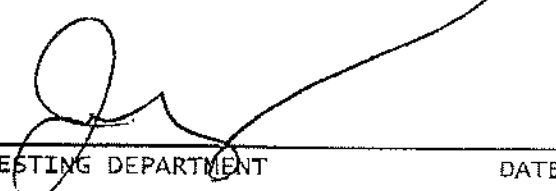
  
\_\_\_\_\_  
REQUESTING DEPARTMENT DATE

Introduced on: March 25, 2014  
Adopted on: March 25, 2014  
Official Resolution#: R20140229

Mar. 14. 2014 1:42PM AS:Passaic County  
 CU OF PASSAIC, PUBLIC BLDGS  
 (Q) 973-881-4425  
 317 PENNSYLVANIA AVENUE  
 PATERSON, NJ 07503

No. 8621 P. 4	
REQUISITION	Res-Pg:1.30-8
NO.	R4-01821

SHIP TO	COUNTY OF PASSAIC BLDGS & GROUNDS DEPT 317 PENNSYLVANIA AVENUE PATERSON, NJ 07503
VENDOR	VENDOR #: 03547 MONARCH ELECTRIC COMPANY ONE DODGE DRIVE WEST CALDWELL, NJ 07006

ORDER DATE: 02/25/14  
 DELIVERY DATE:  
 STATE CONTRACT:  
 F.O.B. TERMS:

QTY/UNIT	DESCRIPTION	ACCOUNT NO.	UNIT PRICE	TOTAL COST
10.00/EA	ARL LV1 LOW VOLT MTG BRACKER	4-01-20-112-001-207	1.2074	12.07
40.00/EA	1 1/2 INCH EMT CONDUIT	4-01-20-112-001-207	1.3922	55.69
4.00/EA	MILB 666-SC1 NEMA-1 SCR CVR BO	4-01-20-112-001-207	8.9900	35.96
4.00/EA	1-1/2 X90 EMT ELBOW	4-01-20-112-001-207	4.6113	18.45
8.00/EA	BRDGPORT 234-DC2 1-1/2 S/S EMT	4-01-20-112-001-207	1.7370	13.90
4.00/EA	BRDGPORT 244-DC 1-1/2 S/S EMT	4-01-20-112-001-207	1.5660	6.26
8.00/EA	BRDGPORT 325 1-1/2 105D PLSTC	4-01-20-112-001-207	0.2629	2.10
8.00/EA	BRDGPORT 905-S 1-1/2 1H COND S	4-01-20-112-001-207	0.5764	4.61
1.00/EA	SUPER ANCHORS 10-12	4-01-20-112-001-207	8.4200	8.42
10.00/EA	BRDGPORT 804-DC2 1/2 90D2SCR F AS PER QUOTE 1112703-00	4-01-20-112-001-207	0.9598	9.60
	NOTE: FOR 30 KING RD., TOTOWA			
			TOTAL	167.06

Introduced on: March 25, 2014  
 Adopted on: March 25, 2014  
 Official Resolution#: R20140229

REQUESTING DEPARTMENT

DATE



CO OF PASSAIC, PUBLIC BLDGS  
 (Q) 973-881-4425  
 317 PENNSYLVANIA AVENUE  
 PATERSON, NJ 07503

REQUISITION Res-Pg: 1.30-9	
NO.	R4-01952

SHIP TO	COUNTY OF PASSAIC BLDGS&GRNDS DEPT 317 PENNSYLVANIA AVENUE PATERSON, NJ 07503
VENDOR	VENDOR #: 03547 MONARCH ELECTRIC COMPANY ONE DODGE DRIVE WEST CALDWELL, NJ 07006

ORDER DATE: 02/28/14  
 DELIVERY DATE:  
 STATE CONTRACT:  
 F.O.B. TERMS:

QTY/UNIT	DESCRIPTION	ACCOUNT NO.	UNIT PRICE	TOTAL COST
1.00/EA	LEV 2620 LKG FLUSH RCPT	4-01-20-112-001-207	12.0400	12.04
1.00/EA	INT-MAT WP1100WC 1G VERT/HOR W	4-01-20-112-001-207	8.4500	8.45
1.00/EA	CCHO TP7078 1G WP BOX W/3 3/4	4-01-20-112-001-207	8.3700	8.37
1.00/EA	LEV 2621 LKG PLUG L6-30P	4-01-20-112-001-207	9.2700	9.27
1.00/EA	LEV C2623 LKG CONN L6-030R	4-01-20-112-001-207	19.5700	19.57
	AS PER QUOTE 1057187-00			
	NOTE: FOR DPW POMPTON LAKES, NJ			
			TOTAL	57.70

Introduced on: March 25, 2014  
 Adopted on: March 25, 2014  
 Official Resolution#: R20140229

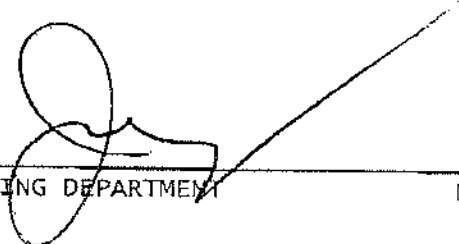
  
 \_\_\_\_\_  
 REQUESTING DEPARTMENT DATE

CO OF PASSAIC, PUBLIC BLDGS  
(Q) 973-881-4425  
317 PENNSYLVANIA AVENUE  
PATERSON, NJ 07503

REQUISITION NO. <b>Res-Pg:1.30-10</b>	
NO.	R4-02051

SHIP TO	COUNTY OF PASSAIC BLDGS & GROUNDS DEPT 317 PENNSYLVANIA AVENUE PATERSON, NJ 07503
VENDOR	VENDOR #: 03547 MONARCH ELECTRIC COMPANY ONE DODGE DRIVE WEST CALDWELL, NJ 07006

ORDER DATE: 03/04/14  
DELIVERY DATE:  
STATE CONTRACT:  
F.O.B. TERMS:

QTY/UNIT	DESCRIPTION	ACCOUNT NO.	UNIT PRICE	TOTAL COST
1.00/EA	C-CS012/3 50 CORD 02725 250FT @ \$1010.38/M FOR ROAD DEPT./307 PENNSYLVANIA AVE. AS PER QUOTE 1052617-00	4-01-20-112-001-207	252.6000	252.60
250.00/FT	C-CSJ012/3 12/3 SJO CORD 01380 FOR DPW POMPTON AS PER QUOTE 1050480-00	4-01-20-112-001-207	0.7091	177.28
			TOTAL	429.88

Introduced on: March 25, 2014  
Adopted on: March 25, 2014  
Official Resolution#: R20140229

REQUESTING DEPARTMENT

DATE

# Passaic County Board of Chosen Freeholders

OFFICE OF THE  
PASSAIC COUNTY FREEHOLDERS

Director Pasquale "Pat" Lepore  
Deputy Director Theodore O. Best, Jr.  
John W. Bartlett  
Ronda Casson Cotroneo  
Terry Duffy  
Bruce James  
Hector C. Lora

401 Grand Street  
Paterson, New Jersey 07505

Tel: 973-881-4402  
Fax: 973-742-3746

Anthony J. De Nova III

Administrator

William J. Pascrell, III, Esq.

County Counsel

Louis E. Imhof, III, RMC

Clerk Of The Board



## Public Meeting (Board Meeting)

Date: Mar 25, 2014 - 5:30 PM

Location: County Administration  
220  
401 Grand Street  
Paterson, NJ 07505

Agenda: RESOLUTION FOR CHANGE ORDER #3 FOR SIMPLEX GRINNELL AS IT PERTAINS TO THE PASSAIC COUNTY JAIL NEW FIRE DETECTION/ALARM AND SUPPRESSION PROJECT, PHASE 1, IN PATERSON, NEW JERSEY, ALL AS NOTED IN THE RESOLUTION

THIS RESOLUTION WAS REQUESTED BY:

REVIEWED BY:

Anthony J. De Nova III  
COUNTY ADMINISTRATOR

APPROVED AS TO FORM AND LEGALITY:

William J. Pascrell, III, Esq.  
COUNTY COUNSEL

Public Works

COMMITTEE NAME

Official Resolution#	R20140230						
Meeting Date	03/25/2014						
Introduced Date	03/25/2014						
Adopted Date	03/25/2014						
Agenda Item	I-31						
CAF #	C-04-55-980-000-902						
Purchase Req. #	PO #10-05764						
Result	Adopted						
FREEHOLDER	PRES.	ABS.	MOVE	SEC	AYE	NAY	ABST.
Lepore	✓				✓		
Best Jr	✓		✓		✓		
Bartlett	✓			✓	✓		
Cotroneo	✓				✓		
Duffy	✓				✓		
James	✓				✓		
Lora	✓				✓		

PRES.= present ABS.= absent  
MOVE= moved SEC= seconded  
AYE= yes NAY= no ABST.= abstain

Dated: March 26, 2014

Res. Pg: 1.31-2

**RESOLUTION FOR CHANGE ORDER #3 FOR SIMPLEX  
GRINNELL AS IT PERTAINS TO THE PASSAIC COUNTY  
JAIL NEW FIRE DETECTION/ALARM AND SUPPRESSION  
PROJECT, PHASE 1, IN PATERSON, NEW JERSEY**

**WHEREAS** a contract was awarded to Simplex Grinnell for the project known as the Passaic County Jail New Fire Detection/Alarm and Suppression Project Phase 1 in Paterson, NJ; and

**WHEREAS** it is now necessary that a change order be made reflecting an increase in the contract amount as noted in the attached correspondence from the Passaic County Engineer; and

**WHEREAS** this matter was discussed and reviewed by the Freeholder Committee for Public Works and Buildings & Grounds at a meeting on March 10, 2014 who recommended that it be approved by the entire Board; and

**WHEREAS** a certification is attached to reflect the availability of funds;

**NOW THEREFORE BE IT RESOLVED** by the Board of Chosen Freeholders of the County of Passaic that the following proposed Change Order No. 3 in connection with the above-mentioned project and recommended for approval by the Office of the Passaic County Engineer by letter dated March 13, 2014 and attached hereto, be and the same is hereby approved.

CHANGE ORDER NO. 3

1. DESCRIPTION AND VALUE OF CHANGE

See March 13, 2014 letter attached hereto

Addition                      \$ 8,329.00

REASON FOR CHANGE

Introduced on: March 25, 2014  
Adopted on: March 25, 2014  
Official Resolution#: R20140230

See March 13, 2014 letter attached hereto

2. STATEMENT OF CONTRACT AMOUNT

Res-Pg:l.31-3

Original Contract Amount		\$ 1,894,400.00
Previous Additions		\$ 15,630.73
Total		\$ 1,910,030.73
Previous Deductions		\$ 21,714.00
Net Prior to This Change		\$ 1,888,316.73
Amount of This Change	Add	\$ 8,329.00
Contract Amount to Date		\$ 1,896,645.73

March 25, 2014

CERTIFICATION OF AVAILABLE FUNDS

THIS IS TO CERTIFY THAT FUNDS ARE AVAILABLE AS FOLLOWS:

AMOUNT: \$8,329.00

APPROPRIATION: C-04-55-980-000-902

PURPOSE: To approve Change Order #3 to contract with Simplex Grinnell as it pertains to the Passaic County Jail New Fire Detection/Alarm and Suppression Project, Phase 1.

  
Michael Katz, County Treasurer

DATED: February 25, 2014

## COUNTY OF PASSAIC RESOLUTION REQUEST FORM

1. NAME OF REQUESTER & Tel # Engineering

DESCRIPTION OF RESOLUTION (PLEASE BE SPECIFIC AS POSSIBLE)

Resolution Approving Change Order # 3, an addition in the amount of \$8,329.00, issued to Simplex Grinell for the Passaic County Fire Alarm and Sprinkler Phase I.

CERTIFICATION INFORMATION:

ATTACH A COPY OF THE REQUISITION FROM EDMONDS

ATTACH A COPY OF A "DETAIL BUDGET ACCOUNT STATUS INCLUDING REQUISITION ITEMS" PAGE FROM EDMONDS

PLEASE NOTE THAT RESOLUTIONS FOR ALL CONTRACT AWARDS AND OTHER EXPENDITURES REQUIRE A REQUISITION. RESOLUTION REQUESTS FOR EXPENDITURES WILL NOT BE CONSIDERED WITHOUT A REQUISITION NUMBER

3. AMOUNT OF EXPENDITURE \$8,329.00

BUDGET ACCOUNT: C-04-55-980-000-902

PURCHASE ORDER # 10-05764

4. COMMITTEE REVIEW: DATE
- |  |                |
|--|----------------|
| <input type="checkbox"/> Administration & Finance                      | _____          |
| <input checked="" type="checkbox"/> Public Works / Buildings & Grounds | <u>3-10-14</u> |
| <input type="checkbox"/> Planning & Economic Development               | _____          |
| <input type="checkbox"/> Health, Human Services & Community Affairs    | _____          |
| <input type="checkbox"/> Law & Public Safety                           | _____          |
| <input type="checkbox"/> Energy  | _____          |
| <input type="checkbox"/> Other Specify: _____                          | _____          |

5. DISTRIBUTION LIST:

Administration  
 Finance  
 Counsel  
 Clerk to Board  
 Procurement  
 Other(s) Specify \_\_\_\_\_



# County of Passaic

Administration Building  
401 Grand Street • Paterson, New Jersey 07505

OFFICE OF THE COUNTY ENGINEER  
ROOM 524

March 13, 2014

Steven J. Edmond, P.E.  
County Engineer

TEL: (973) 881-4456  
FAX: (973) 742-3936  
TDD: (973) 279-9786

Board of Chosen Freeholders  
Administration Building  
401 Grand Street  
Paterson, New Jersey 07505

Re: County Of Passaic  
PC Jail New Fire Detection / Alarm and Suppression Phase 1  
Change Order #3 – Simplex-Grinnell.

Members of the Board:

This Office is in receipt of Change Order #3 in the amount of \$8,329.00 addition to the above referenced project.

This Change Order represents additional costs as indicated:

1. PC Jail Marshall Street additional smoke detectors, annunciator and pull Station in various areas were not included in the original scope of work or indicated on the contract drawings. Work on some of these required to be completed on a weekend due to the use of these areas during the weekdays.
2. PC Jail Marshall Street Basement -Fire Alarm Equipment was damaged and replaced due to steam leak in the Marshall St Basement
3. PC Jail SID Office / Conference Room- added Speaker Strobe / Notification Devices which was not included in the original scope of work.

This Change Order was reviewed and discussed at the Public Works Committee meeting of March 10, 2014 and recommended for approval to the full Board.

Based upon the above, this Office recommends that the Board of Chosen Freeholders adopt a Resolution approving said Change Order #3 in the amount of \$8,329.00 subject to the availability of funds.

Very truly yours,

Steven J. Edmond, P.E.  
County Engineer

/AET  
Attachment

cc: County Administrator  
County Counsel

Introduced on: Director of Finance  
Adopted on: March 25, 2014  
Official Resolution#: R20140230



COUNTY OF PASSAIC

DEPARTMENT OF PUBLIC WORKS  
 ENGINEERING DIVISION  
 401 GRAND STREET  
 PATERSON, NEW JERSEY 07505

CHANGE ORDER No. 3 (Add)  
 PROJECT No.

DATE: March 6, 2014

PROJECT TITLE: PASSAIC COUNTY JAIL- NEW FIRE DETECTION / ALARM AND SUPPRESION PHASE 1  
 LOCATION: 11 MARSHALL STREET PATERSON, NEW JERSEY 07501  
 DATE OF CONTRACT: MARCH 18TH 2010  
 OWNER: PASSAIC COUNTY BOARD OF CHOSEN FREEHOLDERS  
 CONTRACTOR: SIMPLEXGRINNELL

It is hereby mutually agreed that when this Change Order has been signed by the contracting parties the following described changes in work required by the contract shall be executed by the Contractor without changing the terms of the contract except as herein stipulated and agreed:

1. DESCRIPTION AND VALUE OF CHANGE

<u>ADDITIONS:</u> <u>ITEM No. DESCRIPTION</u>	<u>QUANTITY/ UNIT</u>	<u>UNIT PRICE</u>	<u>AMOUNT</u>
1 Marshall Street 3rd Floor Attorney Booths - 3 Additional Smoke Detectors for new video conference spaces	3	693 \$	2,079.00
2 Marshall Street Basement Steam Issue- Fire Alarm Equip was damaged and replaced-1 smoke Detector & 1 CO detector	2	693 \$	2,079.00
3 Marshall Street Added Officers Cage 1 Annunciator, 1 Smoke Detector & 1 Pull Station	3	947 \$	2,841.00
4 Marshall Street & SID Area Added 2 Speaker Strobe / notification Devices	2	665 \$	1,330.00
<b>TOTAL</b>			<b>\$ 8,329.00</b>
 <u>EXTRAS</u>			
<b>TOTAL EXTRAS</b>			<b>\$ -</b>
<b>TOTAL ADDITIONAL</b>			<b>\$ 8,329.00</b>

1. DESCRIPTION AND VALUE OF CHANGE (Con't)

ADD TO THE AMOUNT OF CONTRACT.....	\$ 8,329.00
ORIGINAL DATE FOR COMPLETION.....	April 30, 2011
CURRENT DATE FOR COMPLETION (BASED ON CO # 3).....	August 23, 2011
ADD TO OR DEDUCT FROM - THE PRESENT CONTRACT TIME.....	0 Calendar Days
NEW DATE FOR COMPLETION IS.....	August 23, 2011

2. REASON FOR CHANGE

Items 1-4

- 1- Marshall Street 3rd Floor Attorneys / Video Conference area-Added Additional Smoke Detectors, smoke detectors in the area were not included in the original scope of work and was required to be completed on a weekend due to the use of these areas during the weekdays
- 2- Marshall Street Basement -Fire Alarm Equipment was damaged and replaced due to steam leak in the Marshall St Basement
- 3-Marshall Street Officers Cage- Added Annunciator, Smoke Detector and Pull Station which was not included in the contract drawings submitted to SimplexGrinnell by RJA and were therefore, not

Introduced in the scope of work  
 Adopted by the Board of Chosen Freeholders on March 18, 2014  
 Official Resolution#: R20140230  
 included in the original scope of work

COUNTY OF PASSAIC

DEPARTMENT OF PUBLIC WORKS  
ENGINEERING DIVISION  
401 GRAND STREET  
PATERSON, NEW JERSEY 07505

CHANGE ORDER No.  
PROJECT No.

3 (Adds)

DATE:

March 6, 2014

PROJECT TITLE:PASSAIC COUNTY JAIL- NEW FIRE DETECTION / ALARM AND SUPPRESSION PHASE 1  
LOCATION: 11 MARSHALL STREET PATERSON, NEW JERSEY 07501  
DATE OF CONTRACT: MARCH 18TH 2010  
OWNER: PASSAIC COUNTY BOARD OF CHOSEN FREEHOLDERS  
CONTRACTOR: SIMPLEXGRINNELL

3. STATEMENT OF CONTRACT AMOUNT

ORIGINAL CONTRACT AMOUNT.....	\$ 1,894,400.00
PREVIOUS ADDITIONS.....	\$ 15,630.73
SUBTOTAL.....	\$ 1,910,030.73
PREVIOUS DEDUCTIONS.....	\$ (21,714.00)
NET PRIOR TO THIS CHANGE.....	\$ 1,888,316.73
AMOUNT OF THIS CHANGE.....ADD.....	\$ 8,329.00
CONTRACT AMOUNT TO DATE.....	\$ 1,896,645.73

CONTRACTOR'S PROPOSAL FOR THE ABOVE DESCRIBED CHANGES:

I/We hereby agree to the modifications of the contract as described above and agree to furnish all materials, equipment, and labor to perform all work in connection therewith in accordance with the requirements for similar work in the existing contract except as otherwise stipulated therein for the above consideration.

I/We hereby release the County of Passaic, the Board of Chosen Freeholders, their agents, officers and employees from any claims and liability of whatsoever nature for anything done or furnished or in any manner growing out of the performance of the work.

CONTRACTOR

SIMPLEXGRINNELL

Date: 3/19/2013

You are hereby authorized to supply all labor, equipment, and material for the above change as provided under the terms of your contract; all to be in accordance with the plans and specifications and modifications thereof. Your Contract is increased or decreased by the amount given above which is agreed upon.

Reviewed By and Prepared By: \_\_\_\_\_ Date \_\_\_\_\_  
(County Architect)

Reviewed By and Recommended for Processing By: \_\_\_\_\_ Date \_\_\_\_\_

Recommend for Approval By: \_\_\_\_\_ Date \_\_\_\_\_  
(County Engineer)

ACCEPTED BY: BOARD OF CHOSEN FREEHOLDERS OF PASSAIC COUNTY

SIGNATURE \_\_\_\_\_ DATE: \_\_\_\_\_  
Pat Lepore, Freeholder - Director

# Passaic County Board of Chosen Freeholders

OFFICE OF THE  
PASSAIC COUNTY FREEHOLDERS

Director Pasquale "Pat" Lepore  
Deputy Director Theodore O. Best, Jr.  
John W. Bartlett  
Ronda Casson Cotroneo  
Terry Duffy  
Bruce James  
Hector C. Lora

401 Grand Street  
Paterson, New Jersey 07505

Tel: 973-881-4402  
Fax: 973-742-3746

Anthony J. De Nova III

Administrator

William J. Pascrell, III, Esq.

County Counsel

Louis E. Imhof, III, RMC

Clerk Of The Board



## Public Meeting (Board Meeting)

Date: Mar 25, 2014 - 5:30 PM

Location: County Administration  
220  
401 Grand Street  
Paterson, NJ 07505

Agenda: RESOLUTION APPROVING PLANS AND SPECIFICATIONS AND AUTHORIZING THE ADVERTISEMENT AND RECEIPT OF BIDS FOR THE PROJECT KNOWN AS THE PREAKNESS MINERALS PROJECT IN THE BOROUGH OF HALEDON AND TOWNSHIP OF WAYNE, NEW JERSEY, ALL AS NOTED IN THE RESOLUTION

THIS RESOLUTION WAS REQUESTED BY:

REVIEWED BY:

Anthony J. De Nova III  
COUNTY ADMINISTRATOR

APPROVED AS TO FORM AND LEGALITY:

William J. Pascrell, III, Esq.  
COUNTY COUNSEL

Public Works

COMMITTEE NAME

Official Resolution#		R20140231					
Meeting Date		03/25/2014					
Introduced Date		03/25/2014					
Adopted Date		03/25/2014					
Agenda Item		I-32					
CAF #							
Purchase Req. #							
Result		Adopted					
FREEHOLDER	PRES.	ABS.	MOVE	SEC	AYE	NAY	ABST.
Lepore	✓				✓		
Best Jr	✓		✓		✓		
Bartlett	✓			✓	✓		
Cotroneo	✓				✓		
Duffy	✓				✓		
James	✓				✓		
Lora	✓				✓		

PRES.= present ABS.= absent  
MOVE= moved SEC= seconded  
AYE= yes NAY= no ABST.= abstain

Dated: March 26, 2014

Res. Pg: 1.32-2

**RESOLUTION APPROVING PLANS AND SPECIFICATIONS  
AND AUTHORIZING THE ADVERTISEMENT AND RECEIPT  
OF BIDS FOR THE PROJECT KNOWN AS THE PREAKNESS  
MINERALS PROJECT IN THE BOROUGH OF HALEDON AND  
TOWNSHIP OF WAYNE, NEW JERSEY**

**WHEREAS** the Passaic County Engineer's Office has received the Plans and Specifications for the Project known as the Preakness Minerals Project, Block 29.01, Lot 1 in the Borough of Haledon, NJ and Block 1901, Lot 26 in the Township of Wayne, NJ; and

**WHEREAS** the Passaic County Engineer has reviewed the Plans and Specifications and finds them to be in conformance with Passaic County Engineering Standards; and

**WHEREAS** by letter dated March 17, 2014 the Office of the Passaic County Engineer has recommended that the Board of Chosen Freeholders approve said Plans and Specifications and authorize the Director of Purchasing to receive bids; and

**WHEREAS** this matter has been reviewed by the Freeholder members of the Committee for Public Works & Buildings & Grounds at a meeting on March 10, 2014 who are recommending approval by the entire Board;

**NOW THEREFORE BE IT RESOLVED** by the Board of Chosen Freeholders of the County of Passaic that it hereby approves the Plans and Specifications for the aforementioned project and authorizes the Director of Purchasing to advertise and receive bids for this project.

March 25, 2014



# County of Passaic

Administration Building  
401 Grand Street • Paterson, New Jersey 07505

OFFICE OF THE COUNTY ENGINEER  
ROOM 524

Steven J. Edmond, P.E.  
County Engineer

March 17, 2014

TEL: (973) 881-4456  
FAX: (973) 742-3936  
TDD: (973) 279-9786

Board of Chosen Freeholders  
Administration Building  
401 Grand Street  
Paterson, New Jersey 07505

Re: Preakness Minerals  
Block 29.01, Lot 1, Borough of Haledon  
Block 1901, Lot 26, Township of Wayne  
APPROVAL OF PLANS AND SPECIFICATIONS  
AUTHORIZATION TO BID

Members of the Board:

This Office has prepared the specifications and plans for the leasing of 26.9 acres and the extraction of Preakness Basalt on County owned property east of Kattak Parkway (Reinhardt Road) in Wayne and north of Valley View Road in Haledon.

This project was discussed at the Public Works Committee meeting of March 10, 2014 and recommended for approval to the full Board.

Based upon the above, I recommend that the Board of Chosen Freeholders adopt a Resolution approving the plans and specifications and authorizing the Department of Purchasing to advertise and receive bids for the Preakness Minerals project.

Very truly yours,

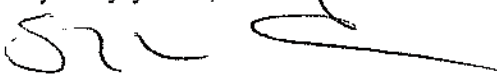

Steven J. Edmond, P.E.  
County Engineer

SJE:ibm

cc: County Administrator  
County Counsel  
Department of Purchasing  
Public Works Chair

Introduced on: March 25, 2014  
Adopted on: March 25, 2014  
Official Resolution#: R20140231

# Passaic County Board of Chosen Freeholders

OFFICE OF THE  
PASSAIC COUNTY FREEHOLDERS

Director Pasquale "Pat" Lepore  
Deputy Director Theodore O. Best, Jr.  
John W. Bartlett  
Ronda Casson Cotroneo  
Terry Duffy  
Bruce James  
Hector C. Lora

401 Grand Street  
Paterson, New Jersey 07505

Tel: 973-881-4402  
Fax: 973-742-3746

Anthony J. De Nova III

Administrator

William J. Pascrell, III, Esq.

County Counsel

Louis E. Imhof, III, RMC

Clerk Of The Board



## Public Meeting (Board Meeting)

Date: Mar 25, 2014 - 5:30 PM

Location: County Administration  
220  
401 Grand Street  
Paterson, NJ 07505

Agenda: RESOLUTION APPROVING PLANS AND SPECIFICATIONS AND AUTHORIZING THE ADVERTISEMENT AND RECEIPT OF BIDS FOR THE PROJECT KNOWN AS THE WEST MILFORD SALT STORAGE PROJECT IN THE TOWNSHIP OF WEST MILFORD, NEW JERSEY, ALL AS NOTED IN THE RESOLUTION

THIS RESOLUTION WAS REQUESTED BY:

REVIEWED BY:

Anthony J. De Nova III  
COUNTY ADMINISTRATOR

APPROVED AS TO FORM AND LEGALITY:

William J. Pascrell, III, Esq.  
COUNTY COUNSEL

Public Works

COMMITTEE NAME

<b>Official Resolution#</b>		<b>R20140232</b>					
Meeting Date		03/25/2014					
Introduced Date		03/25/2014					
Adopted Date		03/25/2014					
Agenda Item		I-33					
CAF #							
Purchase Req. #							
Result		Adopted					
<b>FREEHOLDER</b>	<b>PRES.</b>	<b>ABS.</b>	<b>MOVE</b>	<b>SEC</b>	<b>AYE</b>	<b>NAY</b>	<b>ABST.</b>
Lepore	✓				✓		
Best Jr	✓		✓		✓		
Bartlett	✓			✓	✓		
Cotroneo	✓				✓		
Duffy	✓				✓		
James	✓				✓		
Lora	✓				✓		

PRES.= present ABS.= absent  
MOVE= moved SEC= seconded  
AYE= yes NAY= no ABST.= abstain

Dated: March 26, 2014

Res. Pg: 1.33-2

**RESOLUTION APPROVING PLANS AND SPECIFICATIONS  
AND AUTHORIZING THE ADVERTISEMENT AND RECEIPT  
OF BIDS FOR THE PROJECT KNOWN AS THE WEST  
MILFORD SALT STORAGE PROJECT IN THE TOWNSHIP OF  
WEST MILFORD, NEW JERSEY**

**WHEREAS** the Passaic County Engineer's Office has received the Plans and Specifications for the Project known as the West Milford Salt Storage Project in the Township of West Milford, NJ; and

**WHEREAS** the Passaic County Engineer has reviewed the Plans and Specifications and finds them to be in conformance with Passaic County Engineering Standards; and

**WHEREAS** by letter dated March 12, 2014 the Office of the Passaic County Engineer has recommended that the Board of Chosen Freeholders approve said Plans and Specifications and authorize the Director of Purchasing to receive bids; and

**WHEREAS** this matter has been reviewed by the Freeholder members of the Committee for Public Works & Buildings & Grounds at a meeting on March 10, 2014 who are recommending approval by the entire Board;

**NOW THEREFORE BE IT RESOLVED** by the Board of Chosen Freeholders of the County of Passaic that it hereby approves the Plans and Specifications for the aforementioned project and authorizes the Director of Purchasing to advertise and receive bids for this project.

March 25, 2014



# County of Passaic

Administration Building  
401 Grand Street • Paterson, New Jersey 07505

OFFICE OF THE COUNTY ENGINEER  
ROOM 524

Steven J. Edmond, P.E.  
County Engineer

TEL: (973) 881-4456  
FAX: (973) 742-3936  
TDD: (973) 279-9786

March 12, 2014

Board of Chosen Freeholders  
Passaic County Administration Building  
401 Grand Street  
Paterson, New Jersey 07505

PROJECT: West Milford Salt Storage Building  
Township of West Milford, Passaic County  
**APPROVAL OF PLANS AND SPECIFICATIONS  
AUTHORIZATION TO BID**

Dear Members of the Board:

West Milford's design Consultant, Ferriero Engineering, Inc. of Chester, NJ, has designed and prepared the proposed West Milford Salt Storage Project in the Township of West Milford.

My office has reviewed the Plans and Specifications and find them in conformance with Passaic County and other Engineering Standards.

The above-mention Project was discussed and recommended for approval at the Public Works Committee Meeting of March 10, 2014.

Therefore, I recommend that the Board of Chosen Freeholders ADOPT the necessary RESOLUTION, approving the Plans and Specifications, and authorize the Department of Procurement to advertise and receive bids for this Project.

Very truly yours,

Steven J. Edmond, P.E.  
County Engineer

/jcp

cc: Chair, Public Works and Buildings & Grounds Committee  
County Administrator  
County Counsel  
Director of Finance

Introduced on: ~~Director of Purchasing~~  
Adopted by: Jonathan March 26, 2014 Salt Shed BCF\_Authorize to Bid\_2014\_03\_12.doc  
Official Resolution#: R20140232



# Passaic County Board of Chosen Freeholders

OFFICE OF THE  
PASSAIC COUNTY FREEHOLDERS

Director Pasquale "Pat" Lepore  
Deputy Director Theodore O. Best, Jr.  
John W. Bartlett  
Ronda Casson Cotroneo  
Terry Duffy  
Bruce James  
Hector C. Lora

401 Grand Street  
Paterson, New Jersey 07505

Tel: 973-881-4402  
Fax: 973-742-3746

Anthony J. De Nova III

Administrator

William J. Pascrell, III, Esq.

County Counsel

Louis E. Imhof, III, RMC

Clerk Of The Board



## Public Meeting (Board Meeting)

Date: Mar 25, 2014 - 5:30 PM

Location: County Administration  
220  
401 Grand Street  
Paterson, NJ 07505

Agenda: RESOLUTION FOR CHANGE ORDER #6 FOR DRILL CONSTRUCTION CO., INC. AS IT PERTAINS TO THE PASSAIC COUNTY COURT HOUSE COMPLEX ENVELOPE PROJECT AT 71 HAMILTON STREET IN PATERSON, NEW JERSEY, ALL AS NOTED IN THE RESOLUTION

THIS RESOLUTION WAS REQUESTED BY:

REVIEWED BY:

Anthony J. De Nova III  
COUNTY ADMINISTRATOR

APPROVED AS TO FORM AND LEGALITY:

William J. Pascrell, III, Esq.  
COUNTY COUNSEL

Public Works

COMMITTEE NAME

Official Resolution#		R20140233					
Meeting Date		03/25/2014					
Introduced Date		03/25/2014					
Adopted Date		03/25/2014					
Agenda Item		I-34					
CAF #		C-04-55-991-002-901					
Purchase Req. #		PO #12-08323					
Result		Adopted					
FREEHOLDER	PRES.	ABS.	MOVE	SEC	AYE	NAY	ABST.
Lepore	✓				✓		
Best Jr	✓		✓		✓		
Bartlett	✓			✓	✓		
Cotroneo	✓				✓		
Duffy	✓				✓		
James	✓				✓		
Lora	✓				✓		

PRES.= present ABS.= absent  
MOVE= moved SEC= seconded  
AYE= yes NAY= no ABST.= abstain

Dated: March 26, 2014

Pg:1.34-2

**RESOLUTION FOR CHANGE ORDER #6 FOR DRILL  
CONSTRUCTION CO., INC. AS IT PERTAINS TO THE  
PASSAIC COUNTY COURT HOUSE COMPLEX ENVELOPE  
PROJECT AT 71 HAMILTON STREET IN PATERSON, NEW  
JERSEY**

**WHEREAS** a contract was awarded to Drill Construction Co., Inc. for the project known as the Passaic County Court House Complex Envelope Project at 71 Hamilton Street in Paterson, NJ; and

**WHEREAS** it is now necessary that a change order be made reflecting an increase in the contract amount due to revised portico shoring as noted in the attached correspondence from the Passaic County Superintendent of Buildings & Grounds; and

**WHEREAS** this matter was discussed and reviewed by the Freeholder Committee for Public Works and Buildings & Grounds at a meeting on March 10, 2014 who recommended that it be approved by the entire Board; and

**WHEREAS** a certification is attached to reflect the availability of funds;

**NOW THEREFORE BE IT RESOLVED** by the Board of Chosen Freeholders of the County of Passaic that the following proposed Change Order No. 6 in connection with the above-mentioned project and recommended for approval by the Office of the Passaic County Superintendent of Buildings & Grounds by memo dated March 20, 2014 and attached hereto, be and the same is hereby approved.

CHANGE ORDER NO. 6

1. DESCRIPTION AND VALUE OF CHANGE

See March 20, 2014 letter attached hereto

Introduced on: March 25, 2014  
Adopted on: March 25, 2014  
Official Resolution#: R20140233

Addition

\$ 17,164.00

## REASON FOR CHANGE

See March 20, 2014 letter attached hereto

## 2. STATEMENT OF CONTRACT AMOUNT

Original Contract Amount		\$ 1,570,500.00
Previous Additions		\$ 293,624.00
Total		\$ 1,864,124.00
Previous Deductions		\$ 81,660.00
Net Prior to This Change		\$ 1,782,464.00
Amount of This Change	Add	\$ 17,164.00
Contract Amount to Date		\$ 1,799,628.00

March 25, 2014

CERTIFICATION OF AVAILABLE FUNDS

THIS IS TO CERTIFY THAT FUNDS ARE AVAILABLE AS FOLLOWS:

AMOUNT: \$17,164.00

APPROPRIATION: C-04-55-991-002-901

PURPOSE: To approve Change Order #6 to contract with Drill Construction Company, Inc. as it pertains to the Passaic County Courthouse Complex Envelope Project.

  
Michael Katz, County Treasurer

DATED: February 25, 2014



# County of Passaic

Administration Building

317 Pennsylvania Avenue • Paterson, New Jersey 07503

Jack Nigro  
County Superintendent of  
Buildings and Grounds

TEL: (973) 881-4425  
CELLPHONE: (973) 592-2168  
PAGER: (973) 308-0157  
FAX: (973) 754-1988  
E-MAIL: [jackn@passaiccountynj.org](mailto:jackn@passaiccountynj.org)

March 20, 2014

Mr. Michael Glovin, Esq.  
Passaic County Counsel's Office  
401 Grand Street  
Paterson, New Jersey 07505

Re: Court House Complex Envelope Project – Change Order 6  
Revised Portico Shoring at 71 Hamilton Street

Dear Mr. Glovin:

Attached please find Change Order Number 6 for the above referenced Court House Complex Envelope Project. This change order reflects revised portico shoring at 71 Hamilton Street. Upon recalculating the structural integrity of the shoring, it was determined that the shoring must be re-designed and installed from the original plans.

Therefore, an additional amount of Seventeen Thousand One Hundred Sixty-four Dollars (\$17,164.00) is needed.

If you should have any questions, please feel free to contact me.

Very truly yours,

A handwritten signature in black ink, appearing to read "Jack Nigro", with a long horizontal flourish extending to the right.

Jack Nigro, Superintendent  
Buildings and Grounds

JN/esc

Introduced on: March 25, 2014  
Adopted on: March 25, 2014  
Official Resolution#: R20140233

COUNTY OF PASSAIC

DEPARTMENT OF PUBLIC WORKS  
ENGINEERING DIVISION  
401 GRAND STREET  
PATERSON, NEW JERSEY 07505

CHANGE ORDER # 6  
PROJECT NUMBER \_\_\_\_\_  
DATE March 3, 2014

PROJECT TITLE \_\_\_\_\_  
LOCATION \_\_\_\_\_

3. STATEMENT OF CONTRACT AMOUNT

ORIGINAL CONTRACT AMOUNT.....	\$ 1,570,500.00
PREVIOUS ADDITIONS.....	\$ 293,624.00
TOTAL.....	\$ 1,864,124.00
PREVIOUS DEDUCTIONS.....	\$ 81,660.00
NET PRIOR TO THIS CHANGE.....	\$ 1,782,464.00
AMOUNT OF THIS CHANGE.....ADD.....	\$ 17,164.00
CONTRACT AMOUNT TO DATE.....	\$ 1,799,628.00

CONTRACTOR'S PROPOSAL FOR THE ABOVE DESCRIBED CHANGES:

I/We hereby agree to the modifications of the contract as described above and agree to furnish all materials, equipment, and labor to perform all work in connection therewith in accordance with the requirements for similar work in the existing contract except as otherwise stipulated therein for the above consideration.

I/We hereby release the County of Passaic, the Board of Chosen Freeholders, their agents, officers and employees from any claims and liability of whatsoever nature for anything done or furnished or in any manner growing out of the performance of the work.

CONTRACTOR DRILL CONSTRUCTION CO, INC.  
SIGNATURE G. Dell, PRESIDENT DATE 3/5/14

You are hereby authorized to supply all labor, equipment, and material for the above change as provided under the terms of your contract; all to be in accordance with the plans and specifications and modifications thereof. Your Contract is increased or decreased by the amount given above which is agreed upon.

Reviewed By and Prepared By: [Signature] Date \_\_\_\_\_  
(County Inspector)

Reviewed By and Recommended For Processing By: [Signature] Date \_\_\_\_\_  
(Project Engineer)

Recommend for Approval By: \_\_\_\_\_ Date \_\_\_\_\_  
(County Engineer)

ACCEPTED BY: BOARD OF CHOSEN FREEHOLDERS OF PASSAIC COUNTY

SIGNATURE \_\_\_\_\_  
Freeholder Director

DATE \_\_\_\_\_  
Introduced on: March 25, 2014  
Adopted on: March 25, 2014  
Official Resolution#: R20140233

## COUNTY OF PASSAIC

DEPARTMENT OF PUBLIC WORKS  
ENGINEERING DIVISION  
401 GRAND STREET  
PATERSON, NEW JERSEY 07505

CHANGE ORDER # 6  
PROJECT NUMBER  
DATE March 2, 2013

PROJECT TITLE Court House Envelope Project

LOCATION Paterson, N.J.

DATE OF CONTRACT \_\_\_\_\_

OWNER PASSAIC COUNTY BOARD OF CHOSEN FREEHOLDERS

CONTRACTOR Drill Construction

It is hereby mutually agreed that when this Change Order has been signed by the contracting parties the following described changes in work required by contract shall be executed by the Contractor without changing the terms of the contract except as herein stipulated and agreed:

1. DESCRIPTION AND VALUE OF CHANGE

ITEM No.	DESCRIPTION	QUANTITY/UNIT	UNIT PRICE	AMOUNT
<u>ADDITIONS</u>				
	226 Revise Portico Shoring			\$ 17,164.00
TOTAL ADDITIONS				+ \$ 17,164.00
<u>SUPPLEMENTALS</u>				
TOTAL SUPPLEMENTALS				+ \$
TOTAL VALUE OF ADDITIONS AND SUPPLEMENTALS				\$ 17,164.00

COUNTY OF PASSAIC

DEPARTMENT OF PUBLIC WORKS  
ENGINEERING DIVISION  
401 GRAND STREET  
PATERSON, NEW JERSEY 07505

CHANGE ORDER # 6  
PROJECT NUMBER \_\_\_\_\_  
DATE March 3, 2014

PROJECT TITLE \_\_\_\_\_

LOCATION \_\_\_\_\_

1. DESCRIPTION AND VALUE OF CHANGE (Con't)

ADD TO THE AMOUNT OF CONTRACT.....\$ 17,164.00

ORIGINAL TIME FOR COMPLETION..... Calendar Days \_\_\_\_\_

ADD TO OR DEDUCT FROM - THE PRESENT CONTRACT TIME.. NO CHANGE

NEW DATE FOR COMPLETION IS.....

2. REASON FOR CHANGE

Adjustments as Per As-Built Quantities.



# Passaic County Board of Chosen Freeholders

OFFICE OF THE  
PASSAIC COUNTY FREEHOLDERS

Director Pasquale "Pat" Lepore  
Deputy Director Theodore O. Best, Jr.  
John W. Bartlett  
Ronda Casson Cotroneo  
Terry Duffy  
Bruce James  
Hector C. Lora

401 Grand Street  
Paterson, New Jersey 07505

Tel: 973-881-4402  
Fax: 973-742-3746

Anthony J. De Nova III

Administrator

William J. Pascrell, III, Esq.

County Counsel

Louis E. Imhof, III, RMC

Clerk Of The Board



## Public Meeting (Board Meeting)

Date: Mar 25, 2014 - 5:30 PM

Location: County Administration  
220  
401 Grand Street  
Paterson, NJ 07505

Agenda: RESOLUTION DECLARING THAT THE COUNTY OF PASSAIC WISHES TO GO ON RECORD AS URGING THE STATE OF NEW JERSEY LEGISLATURE TO PASS A SUPPLEMENTAL BUDGET APPROPRIATION FOR THE STATE FISCAL YEAR TO REPLACE THE LOSS OF \$5,790,000.00 IN TRANSPORTATION FUNDING, ALL AS NOTED IN THE RESOLUTION

THIS RESOLUTION WAS REQUESTED BY:

REVIEWED BY:

Anthony J. De Nova III  
COUNTY ADMINISTRATOR

APPROVED AS TO FORM AND LEGALITY:

William J. Pascrell, III, Esq.  
COUNTY COUNSEL

Public Works

COMMITTEE NAME

Official Resolution#	R20140234						
Meeting Date	03/25/2014						
Introduced Date	03/25/2014						
Adopted Date	03/25/2014						
Agenda Item	I-35						
CAF #							
Purchase Req. #							
Result	Adopted						
FREEHOLDER	PRES.	ABS.	MOVE	SEC	AYE	NAY	ABST.
Lepore	✓				✓		
Best Jr	✓		✓		✓		
Bartlett	✓			✓	✓		
Cotroneo	✓				✓		
Duffy	✓				✓		
James	✓				✓		
Lora	✓				✓		

PRES.= present ABS.= absent  
MOVE= moved SEC= seconded  
AYE= yes NAY= no ABST.= abstain

Dated: March 26, 2014

**RESOLUTION DECLARING THAT THE COUNTY OF PASSAIC WISHES TO GO ON RECORD AS URGING THE STATE OF NEW JERSEY LEGISLATURE TO PASS A SUPPLEMENTAL BUDGET APPROPRIATION FOR THE STATE FISCAL YEAR TO REPLACE THE LOSS OF \$5,790,000.00 IN TRANSPORTATION FUNDING**

**WHEREAS** the current re-authorization of New Jersey Transportation Trust Fund Authority Act eliminated the Federal Aid Urban System (FAUS) minimum allotment from the County aid distribution formula; and

**WHEREAS** as a result, ten New Jersey Counties, including Passaic County, will collectively lose over \$5,790,000.00 annually in transportation funding translating to a loss through the end of the State's fiscal year 2017 of \$23,160,000.00 at which time the State once again must re-authorize the Fund; and

**WHEREAS** moreover in 2012, the State Department of Transportation reduced local aid allocations by \$10,000,000.00 under the Commissioner's discretionary funding allocations; and

**WHEREAS** as a result of these massive funding cuts several County Governments, including Passaic County, may have to scale back, delay or eliminate needed road and bridge projects; and

**WHEREAS** the Board of Chosen Freeholders of the County of Passaic are desirous of having the New Jersey Legislature appropriate necessary funding to insure that counties who have lost funding continue to have the financial means to perform important road and bridge infrastructure projects in their respective jurisdictions.

**NOW THEREFORE BE IT RESOLVED** by the Board of Chosen Freeholders of the County of Passaic that it wishes to go on record as urging the Legislature of the State of New Jersey to pass a supplemental budget appropriation for the State fiscal year to replace the loss of \$5,790,000.00 in critical transportation funding for New Jersey's most urban and populated counties.

**BE IT FURTHER RESOLVED** that the Clerk to the Board be authorized to forward certified copies of this Resolution to the State Budget Committee members in both the New Jersey State Senate and General Assembly and to all members of the New Jersey State Legislature representing any portion of the County of Passaic.

March 25, 2014

# Passaic County Board of Chosen Freeholders

OFFICE OF THE  
PASSAIC COUNTY FREEHOLDERS

Director Pasquale "Pat" Lepore  
Deputy Director Theodore O. Best, Jr.  
John W. Bartlett  
Ronda Casson Cotroneo  
Terry Duffy  
Bruce James  
Hector C. Lora

401 Grand Street  
Paterson, New Jersey 07505

Tel: 973-881-4402  
Fax: 973-742-3746

Anthony J. De Nova III

Administrator

William J. Pascrell, III, Esq.

County Counsel

Louis E. Imhof, III, RMC

Clerk Of The Board



## Public Meeting (Board Meeting)

Date: Mar 25, 2014 - 5:30 PM

Location: County Administration  
220  
401 Grand Street  
Paterson, NJ 07505

Agenda: RESOLUTION AUTHORIZING AWARD OF CONTRACT TO GOLF CHANNEL SOLUTIONS FOR RECEIPT OF REVENUE FOR FOUR TEE TIMES AT THE PREAKNESS VALLEY GOLF COURSE ON A DAILY BASIS FOR A TWO-YEAR PERIOD IN RETURN FOR PROMOTION AND MARKETING SERVICES TO BE PROVIDED FOR THE COURSE, ALL AS NOTED IN THE RESOLUTION

THIS RESOLUTION WAS REQUESTED BY:

REVIEWED BY:

Anthony J. De Nova III  
COUNTY ADMINISTRATOR

APPROVED AS TO FORM AND LEGALITY:

William J. Pascrell, III, Esq.  
COUNTY COUNSEL

Public Works

COMMITTEE NAME

<b>Official Resolution#</b>		<b>R20140235</b>					
Meeting Date		03/25/2014					
Introduced Date		03/25/2014					
Adopted Date		03/25/2014					
Agenda Item		I-36					
CAF #							
Purchase Req. #							
Result		Adopted					
<b>FREEHOLDER</b>	<b>PRES.</b>	<b>ABS.</b>	<b>MOVE</b>	<b>SEC</b>	<b>AYE</b>	<b>NAY</b>	<b>ABST.</b>
Lepore	✓				✓		
Best Jr	✓		✓		✓		
Bartlett	✓			✓	✓		
Cotroneo	✓				✓		
Duffy	✓				✓		
James	✓				✓		
Lora	✓				✓		

PRES.= present ABS.= absent  
MOVE= moved SEC= seconded  
AYE= yes NAY= no ABST.= abstain

Dated: March 26, 2014

R20140235-2  
Pg. 1 of 2

**RESOLUTION AUTHORIZING AWARD OF CONTRACT TO GOLF CHANNEL SOLUTIONS FOR RECEIPT OF REVENUE FOR FOUR TEE TIMES AT THE PREAKNESS VALLEY GOLF COURSE ON A DAILY BASIS FOR A TWO-YEAR PERIOD IN RETURN FOR PROMOTION AND MARKETING SERVICES TO BE PROVIDED FOR THE COURSE**

**WHEREAS** over the last several months the Passaic County Parks Director/Golf Manager has been working with a company known as Golf Channel Solutions of Orlando, Florida or (GCS) also known as Golf Now, a subsidiary of the NBC/Universal Sports Group, whereby the Passaic County Parks Department allows said GCS to keep the revenue from one tee time per day for each of the two Courses (Blue and Red) in return for promoting the Passaic County-owned Preakness Valley Golf Course(s); and

**WHEREAS** said GCS has recently approached the Passaic County Administration about expanding its promotion efforts for the Preakness Valley Golf Course by, among other things, promoting the Course on its Golfnow.com website, helping the Course in developing its own customized and unique website, develop its own booking engine on that site and several items as set forth in the attached proposed agreement in return for two dedicated revenue tee times per day for each of the two courses for a total of four (4) for a two (2) year period (see copy of memo dated March 20, 2014 attached hereto and made a part hereof); and

**WHEREAS** while the value of the time tees per day is not clear, it may be in excess of the \$17,500 threshold set forth under the Pay to Play Law (N.J.S.A. 19:44A-20.3 et seq.); and

**WHEREAS** the said Board, by Resolution 06-97 dated February 14, 2006 established a policy of only awarding contracts

in excess of the monetary threshold set forth under the ~~Res Pg:1.36-3~~  
Play Law only under a fair and open process; and

**WHEREAS** the Board is desirous of making an exception to that policy in this case in order to take advantage of the unique service and opportunity offered by Golf Channel Solutions; and

**WHEREAS** the Freeholder Committee for Public Works and Buildings & Grounds at its March 10, 2014 meeting reviewed this matter and is recommending approval by the full Board.

**NOW THEREFORE BE IT RESOLVED** by the Board of Chosen Freeholders of the County of Passaic that it hereby authorizes a non-fair and non-open award of contract to Golf Channel Solutions (GCS) of Orlando, Florida by which the said vendor will be permitted to utilize all revenues for two tee times at both of the Preakness Valley Golf Course(s) (Red and Blue) for a two (2)-year period in return for providing the promotion services set forth in the attached agreement.

**BE IT FURTHER RESOLVED** that this contract is being awarded as an exception to the policy of the Board as set forth in its Resolution R-06-97 dated February 14, 2006 because of the special circumstances of this situation, and the policy of the Board as set forth in this resolution shall remain in full force and effect; and

**BE IT FURTHER RESOLVED** that the Director and Clerk of the said Board are hereby authorized to execute any necessary agreement on behalf of the County of Passaic.

March 25, 2013

TO: Michael Glovin, Esq.  
Law Department

FROM: Nick Roca, Director  
Preakness Valley Golf Courses

RE: GOLF NOW AGREEMENT

DATE: March 20, 2014

---

Please accept this as my full support of the proposed agreement between the Preakness Valley Golf Course and Golf Now, LLC. After a successful sampling of how Golf Now's reservation service works, there is no doubt that this agreement will benefit Preakness Valley Golf Course by exposing our course availability to a broader golfer population, fill tee times we have designated as poorly used by our regular membership and providing an instant marketing opportunity to advertise special golf opportunities.

Golf Now is a unique service affiliated and promoted by the PGA tour. Our brief sampling in 2013 of their service produced revenue at an approximate 5 to 1 ratio adding approximately \$25,000 to our bottom line on a limited basis and time frame. At these rates, our calculations lead us to believe that the revenue earned by Golf Now will not violate any of the thresholds set forth in the public bid regulations. I fully support the additional tee time allotted to Golf Now for their use and giving them the same access on our second course resulting in a total of 4 tee lines for the use of Golf Now within the time frames pre-set throughout the year.

In our opinion, this agreement with Golf Now lends to the overall effort by the county to upgrade and move forward our county golf service.

NR/cp



## GolfNow Software License/Marketing/Technology Agreement and Order Form

The following Agreement between GolfNow G1, LLC ("GOLFNOW") and \_\_\_\_\_ ("COURSE") shall be effective as of \_\_\_\_\_ (the "Effective Date") and shall govern GOLFNOW's provision of software, marketing, and technology services for the following of COURSE's golf courses: \_\_\_\_\_. This Agreement shall be governed by the Standard Terms and Conditions attached hereto as Appendix A (incorporated herein by this reference). The initial Term of this Agreement shall be for two (2) years and shall be non-cancellable. Upon expiration of the initial Term, this Agreement shall automatically renew for successive one (1) year terms unless terminated by either Party in writing at least thirty (30) days prior to any renewal term. COURSE's Total Payment to GOLFNOW shall be in the amount indicated below, in exchange for which GOLFNOW shall provide COURSE with access to the below-referenced services (the "Services") upon COURSE's request, and an annual license to the below-referenced software (the "Software").

**FORE Reservations Software Modules:** GOLFNOW shall provide COURSE with an annual license to each of the following FORE modules:

- FORE Reservations electronic tee sheet reservation system;
- FORE Sell point of sale software;
- FORE Marketing;
- FORE Cloud Backup.

**GolfNow Core Platform:**

- Promotion of COURSE and COURSE tee time inventory on Golfnow.com and GolfNow's network of partner websites;
- Marketing of COURSE across GOLFNOW assets (could include TV, web, print, radio, grassroots);
- Demand-based pricing support, Revenue at risk analysis, Tee sheet management services, Dedicated market management team, Real-time reporting; and
- GolfNow Central Technology: Web-based log in access, inclusive of online tools for managing tee time inventory and revenue management and auto adjust technology.

**COURSE Booking Engine and Facebook Booking Engine\*\*:** GOLFNOW shall develop COURSE's own golf course booking engine (to be hosted on COURSE website) and COURSE Facebook Booking Engine (if applicable). Course shall make Trade Times available for purchase on the Booking Engine(s). Among the features available for COURSE are: Customizable booking engine components, Multiple rate options, Promotional code technology.

**GolfNow Mail:** GOLFNOW shall develop COURSE Mail Customer Marketing Tool (to be integrated into COURSE GolfNow Central login). Among the features available for COURSE are: Multiple design and template options, Email marketing, customer profiles and segmentation.

**Website and Mobile Website Development and Hosting:** GOLFNOW shall develop COURSE's own customized and unique desktop website and mobile website (each to be hosted on COURSE-owned domains), utilizing one of several GOLFNOW templates designed to highlight specific COURSE features and programs. GOLFNOW and COURSE shall work cooperatively to identify appropriate COURSE features.

**TeeTimes.com:** GOLFNOW shall include COURSE on TeeTimes.com website and mobile application.

**Total Payment:** 4 Trade Times per day per facility

COURSE Signature: \_\_\_\_\_

Printed Name: \_\_\_\_\_

GOLFNOW Signature: \_\_\_\_\_

Printed Name: \_\_\_\_\_

**Trade Time:** one 18-hole foursome (with cart) made available for sale by GOLFNOW for its own benefit, the tee time of which shall be mutually agreed upon and between 30 minutes after COURSE opening until 4.5 hours prior to dusk. GOLFNOW shall have the ability to sell Trade Times for 1-4 players and the price is at the discretion of GOLFNOW. Trade Times shall be available for purchase on COURSE website, golfnow.com, and GOLFNOW's network of partner websites.

**\*\*Split Online Fee:** if COURSE elects to charge an online fee for rounds booked on its website, GOLFNOW shall retain .99¢/round and remit the remainder to COURSE.



**Appendix A  
Standard Terms and Conditions**

1. GOLFNOW Services. GOLFNOW shall provide GOLFNOW's Tee Time Marketing and Technology Services (the "Services") for the purpose of marketing, promoting and selling COURSE tee times and enhancing COURSE's technology. GOLFNOW shall provide access to COURSE tee times to any of its branded websites, partner or affiliated websites or any other distribution channel. COURSE shall honor all tee times reserved through GOLFNOW's distribution channels and shall treat all golfers originating from GOLFNOW with proper courtesy and respect. COURSE shall make every effort to maintain its inventory in the most up-to-date manner possible, with proper communication to GOLFNOW regarding changes in availability, course conditions, etc... The Parties shall work cooperatively to minimize double-bookings, cancellations and the like.
2. GOLFNOW Software. GOLFNOW grants COURSE a limited, non-exclusive, non-transferable license to utilize the FORE Reservations Software (the "Software") as set forth on the included Order Form. COURSE may use the Software for the purpose of managing and marketing COURSE's golf course properties and may not sell, sublicense, lend, or otherwise transfer the Software to others. Neither COURSE, nor any third party working with or on behalf of COURSE, may reverse engineer, decompile, disassemble, or customize the Software including but not limited to, creating any software interface with the Software for the purpose of selling or marketing of tee times through the Internet or any internet site, without the express knowledge and written agreement of GOLFNOW. COURSE understands and acknowledges that all third party vendors must have a written agreement with GOLFNOW in order to create any interface with the Software.
3. Fees and Pricing. COURSE's only payment to GOLFNOW shall be the "Total Payment" amount set forth on the Order Form attached hereto. COURSE shall have the right to approve the price and amount of all non-Trade Time inventory offered in the GOLFNOW network. GOLFNOW shall receive tee times and rates equal to or better than those offered by COURSE to any third-party distribution service. In the event that COURSE does not comply with the pricing requirements hereunder or otherwise fails to cooperate with the terms of this Agreement resulting in the Agreement being terminated by GOLFNOW, COURSE shall be required to pay GOLFNOW a fee of \$250/month for each month after termination through the end of the current Term.
4. Term and Termination. The initial Term of this Agreement shall be for two (2) years and shall be non-cancellable. Upon expiration of the initial Term, this Agreement shall automatically renew for successive one (1) year terms unless terminated by either Party in writing at least thirty (30) days prior to any renewal term. Either Party may immediately terminate this Agreement in the event that the other Party materially breaches the Agreement and fails to cure such breach within thirty (30) days' written notice. Upon termination of this Agreement, COURSE shall delete and return all Software and all copies and sign a statement certifying same.
5. Support and Training. GOLFNOW shall provide COURSE appropriate levels of training (including access to remote training and on-line resources). Additional in-person training may be provided for an additional fee. Telephone and email support shall be provided to COURSE during normal business hours through GOLFNOW's published phone numbers and email addresses.
6. Data Security. Industry standards have been set by the Payment Card Industry Data Security Standards ("PCI Standards") for protection of customer information. The Parties represent and warrant that they will comply with PCI Standards during the entire Term of this Agreement and thereafter with respect to customer data accumulated during the Term, and further agree to adhere to all other applicable standards, laws, rules, and regulations for protection of customer data to which they have access during the entire Term of this Agreement. GOLFNOW agrees that it will use systems, tools and security and take commercially reasonable steps to ensure COURSE customer data hosted by GOLFNOW is not accessed, redistributed, duplicated, or modified.
7. Limited Warranties and Remedies. Both Parties represent and warrant that: (a) they have the authority to enter into this Agreement and that their signatories are duly authorized and empowered to sign this Agreement on their behalf; (b) they will comply with all applicable laws, ordinances, statutes, regulations and rules, and that they have the power to settle fully and completely all claims, causes of action, demands, charges and liabilities arising out of or relating to the Agreement. GOLFNOW will provide the Services and the Software in a professional and workmanlike manner and free from any unreasonable defects, and GOLFNOW will use all reasonable means to fix any defect in the Software or Services that may arise. GOLFNOW will provide COURSE with training on how to use the Software and Services and provide support as needed by COURSE. GOLFNOW shall notify COURSE in advance of any Software or Service updates and will provide appropriate training and/or materials to COURSE concerning all updates. COURSE and its authorized users will use the Software and Services only in accordance with this Agreement. Aside from these warranties, THE GOLFNOW SOFTWARE AND SERVICES ARE PROVIDED WITHOUT WARRANTY OF ANY KIND, EITHER EXPRESS OR IMPLIED, INCLUDING BUT NOT LIMITED TO ANY IMPLIED WARRANTY OF MERCHANTABILITY OR FITNESS FOR A PARTICULAR PURPOSE OR USE. With respect to malfunctioning Software, GOLFNOW's entire liability and COURSE's exclusive remedy shall be either repair/replacement of the Software.
8. Limitation of Liability. EXCEPT FOR THIRD PARTY LIABILITIES, IN NO EVENT SHALL EITHER PARTY BE LIABLE FOR ANY SPECIAL, INCIDENTAL, INDIRECT, CONSEQUENTIAL, EXEMPLARY OR PUNITIVE DAMAGES (INCLUDING, WITHOUT LIMITATION, ANY DAMAGES BASED ON LOSS OF PROFITS, LOSS OF USE, BUSINESS INTERRUPTION OR LOSS OF DATA), EVEN IF SUCH PARTY HAS BEEN ADVISED OF THE POSSIBILITY OF SUCH DAMAGES. THE FOREGOING LIMITATIONS SHALL APPLY REGARDLESS OF THE CAUSE OR THE FORM OF ACTION (WHETHER BREACH OF CONTRACT, BREACH OF WARRANTY, NEGLIGENCE, STRICT LIABILITY OR OTHERWISE).

9. Ownership of Property and Data. All personally-identifiable customer information supplied to GOLFNOW by COURSE (e.g. through the GOLFNOW booking engine or through the Software) remains the sole property of COURSE, cannot be copied, sold or reused by GOLFNOW, and will be treated as confidential business information with at least the same degree of care as GOLFNOW's own confidential business information. All non-personally identifiable customer information supplied to GOLFNOW by COURSE (e.g., anonymous survey results, general usage data), as well as all customer data obtained independently by GOLFNOW (e.g., through an end-user booking a tee time at golfnow.com or other affiliated websites) shall be GOLFNOW's sole property, but may be shared with COURSE should the Parties agree and obtain end-user consent for such an arrangement. The following shall remain the sole and exclusive property of GOLFNOW: (a) the GOLFNOW Software and Services (including any of GOLFNOW's enhancements or upgrades thereto), and all other software and materials developed, conceived, originated, prepared, generated or furnished by GOLFNOW under this Agreement; and (b) all copyrights, trademarks, patents, trade secrets and any other intellectual property and proprietary rights in and to the foregoing. To the extent that GOLFNOW has provided COURSE with any hardware, all such hardware shall remain GOLFNOW's property and shall be returned by COURSE to GOLFNOW upon the earlier of termination of this Agreement due to breach or expiration of the Term.

10. Dispute Resolution. This Agreement shall be governed, interpreted and construed under the laws of the United States and the State of Florida without regard to any conflict of law principles. The Parties shall act in good faith and use commercially reasonable efforts to promptly resolve any claim, dispute, controversy or disagreement (each a "Dispute") between the Parties under or related to this Agreement. Any Dispute arising out of this Agreement which cannot be resolved by the Parties shall be governed exclusively by binding arbitration initiated and conducted in accordance with the Commercial Arbitration Rules of the American Arbitration Association, conducted in the Orlando, Florida metropolitan area. The arbitrator shall have the power to award reasonable attorney's fees and costs to the prevailing party in any arbitration, and either party shall have the right to take appropriate action to enforce any arbitration award in any court having jurisdiction over the applicable party.

11. Miscellaneous. This Agreement shall constitute the entire understanding of the Parties with respect to the subject matter hereof and supersedes any and all prior understandings and agreements, written or oral, relating thereto ~ between COURSE and GOLFNOW or FORE Reservations. Except as otherwise provided herein, GOLFNOW may amend the terms and conditions of this Agreement by giving COURSE at least 60 days prior written notice thereof and giving COURSE the option to terminate this Agreement within 30 days of receipt of such notice. This Agreement may be executed in one or more counterparts, with electronic exchange of signatures (pdf) sufficient to bind the Parties. The Agreement shall be binding upon GOLFNOW and COURSE and their respective successors and assigns; provided, however, that COURSE shall not assign this Agreement or any of its rights or obligations hereunder, without the prior written consent of GOLFNOW, which consent shall not be unreasonably withheld, conditioned, or delayed. Any subcontractors retained by GOLFNOW to perform certain obligations hereunder shall be bound by and their actions are governed by this Agreement as if GOLFNOW itself was performing such obligations.

Traffic Assignment Request for comScore Inc. Reporting

I, \_\_\_\_\_ (Name), \_\_\_\_\_ (Title) of \_\_\_\_\_ certify that \_\_\_\_\_ (COURSE)

- a) is the majority owner of the URLs listed below
- b) enjoys a legitimate business relationship with Golf Channel justifying the aggregation of this traffic, and
- c) requests assignment of the traffic to these URLs from COURSE to Golf Channel; in the comScore Inc. syndicated audience measurement reports.

In requesting this assignment, I understand that the COURSE will independently contribute traffic associated with the publisher from the assigned URLs in the syndicated audience reports for those entities where Golf Channel elects to include these URLs. This assigned traffic will contribute to Golf Channel's overall traffic, while remaining independently reportable. These URLs may not be assigned to any other company. In the event that comScore Inc. receives multiple requests for assignment of the same URL, comScore Inc. will review and honor the request most recently received.

I understand that this request is subject to review by comScore Inc. to determine that the assignment of traffic is consistent with comScore Inc. reporting rules. comScore Inc. retains the right in its sole discretion to refuse the requested assignment if such assignment would in fact be inconsistent with comScore Inc. reporting rules. If necessary, comScore Inc. may require additional documentation to verify ownership of the URLs before granting this request. For example, if COURSE is not the named registrant of the URLs listed below, COURSE must provide documentation demonstrating that the registrant of those URLs is (1) owned or (2) employed by COURSE.

I understand that acceptance of this letter by comScore Inc. imposes no legal liability whatsoever on comScore Inc. for damages, whether actual, incidental or consequential, relating to the maintenance or reporting of the attached URLs. I understand that the COURSE is fully responsible for timely notification to comScore Inc. of any updates to the list below, including, but not limited to, changes in ownership of any of those URLs.

COURSE shall indemnify and hold harmless comScore Inc. from and against any claims, liabilities, costs and expenses of any kind (including reasonable attorney's fees and expenses) arising out of any allegation of improper assignment of the URLs pursuant to this letter.

[List of URLs here]

\_\_\_\_\_  
\_\_\_\_\_  
\_\_\_\_\_

\_\_\_\_\_  
Signature

\_\_\_\_\_  
Name

\_\_\_\_\_  
Title

\_\_\_\_\_  
COURSE

\_\_\_\_\_  
Date

# Passaic County Board of Chosen Freeholders

OFFICE OF THE  
PASSAIC COUNTY FREEHOLDERS

Director Pasquale "Pat" Lepore  
Deputy Director Theodore O. Best, Jr.  
John W. Bartlett  
Ronda Casson Cotroneo  
Terry Duffy  
Bruce James  
Hector C. Lora

401 Grand Street  
Paterson, New Jersey 07505

Tel: 973-881-4402  
Fax: 973-742-3746

Anthony J. De Nova III

Administrator

William J. Pascrell, III, Esq.

County Counsel

Louis E. Imhof, III, RMC

Clerk Of The Board



## Public Meeting (Board Meeting)

Date: Mar 25, 2014 - 5:30 PM

Location: County Administration  
220  
401 Grand Street  
Paterson, NJ 07505

Agenda: RESOLUTION FOR CHANGE ORDER #5 TO DRILL CONSTRUCTION CO., INC. AS IT PERTAINS TO THE PASSAIC COUNTY COURT HOUSE COMPLEX ENVELOPE PROJECT AT 71 & 77 HAMILTON STREET IN PATERSON, ALL AS NOTED IN THE RESOLUTION

THIS RESOLUTION WAS REQUESTED BY:

REVIEWED BY:

Anthony J. De Nova III  
COUNTY ADMINISTRATOR

APPROVED AS TO FORM AND LEGALITY:

William J. Pascrell, III, Esq.  
COUNTY COUNSEL

Public Works

COMMITTEE NAME

<b>Official Resolution#</b>	<b>R20140236</b>						
Meeting Date	03/25/2014						
Introduced Date	03/25/2014						
Adopted Date	03/25/2014						
Agenda Item	I-37						
CAF #							
Purchase Req. #							
Result	Adopted						
<b>FREEHOLDER</b>	<b>PRES.</b>	<b>ABS.</b>	<b>MOVE</b>	<b>SEC</b>	<b>AYE</b>	<b>NAY</b>	<b>ABST.</b>
Lepore	✓				✓		
Best Jr	✓		✓		✓		
Bartlett	✓			✓	✓		
Cotroneo	✓				✓		
Duffy	✓				✓		
James	✓				✓		
Lora	✓				✓		

PRES.= present ABS.= absent  
MOVE= moved SEC= seconded  
AYE= yes NAY= no ABST.= abstain

Dated: March 26, 2014

**RESOLUTION FOR CHANGE ORDER #5 TO DRILL  
CONSTRUCTION CO., INC. AS IT PERTAINS TO THE  
PASSAIC COUNTY COURT HOUSE COMPLEX ENVELOPE  
PROJECT AT 71 & 77 HAMILTON STREET IN PATERSON,  
NJ**

**WHEREAS** a contract was awarded to Drill Construction Co., Inc. for the project known as the Passaic County Court House Complex Envelope Project at 71 Hamilton Street in Paterson, NJ; and

**WHEREAS** it is now necessary that a change order be made reflecting decreases due to the omission of PVC drainpipes at 71 Hamilton Street and the omission of caulking around base at 77 Hamilton Street ; and

**WHEREAS** this matter was discussed and reviewed by members of the Freeholder Public Works and Buildings & Grounds Committee at the meeting of March 10, 2014 who recommended that it be approved by the entire Board; and

**NOW THEREFORE BE IT RESOLVED** by the Board of Chosen Freeholders of the County of Passaic that the following proposed Change Order No. 5 in connection with the above-mentioned project, and recommended for approval by the Passaic County Superintendent of Buildings & Grounds by memo dated March 20, 2014 and attached hereto, be and the same is hereby approved:

CHANGE ORDER NO. 5

DESCRIPTION AND VALUE OF CHANGE

See letter March 20, 2014 attached hereto

Deduction	\$ 3,657.00
-----------	-------------

## REASON FOR CHANGE

See letter March 20, 2014 attached hereto

## 1. STATEMENT OF CONTRACT AMOUNT

Original Contract Amount		\$1,570,500.00
Previous Additions		293,624.00
Total		1,864,124.00
Previous Deductions		78,003.00
Net Prior to This Change		1,786,121.00
Amount of This Change	Deduct	3,657.00
Contract Amount to Date		1,782,464.00

March 25, 2014



# County of Passaic

Administration Building

317 Pennsylvania Avenue • Paterson, New Jersey 07503

Jack Nigro  
County Superintendent of  
Buildings and Grounds

TEL: (973) 881-4425  
CELLPHONE: (973) 592-2168  
PAGER: (973) 308-0157  
FAX: (973) 754-1988  
E-MAIL: jackn@passaiccountynj.org

March 20, 2014

Mr. Michael Glovin, Esq.  
Passaic County Counsel's Office  
401 Grand Street  
Paterson, New Jersey 07505

Re: Court House Complex Envelope Project – Change Order No. 5  
Omit PVC Drainage 71 Hamilton Street  
Omit Caulking Around Base at 77 Hamilton Street

Dear Mr. Glovin:

Attached please find Change Order Number 5 for the above referenced Court House Complex Envelope Project. This change order reflects omitting PVC drainpipes at 71 Hamilton Street and omitting caulking around base at 77 Hamilton Street. This Change Order was reviewed and was decided that the drainpipes at the portico were not needed and also the caulk sealant around the base of the Plaza was in good condition and also was not needed.

Therefore a deduction from the original contract is in order in the amount of Three Thousand Six Hundred Fifty-seven Dollars (\$ 3,657.00).

If you should have any questions, please feel free to contact me.

Very truly yours,

A handwritten signature in black ink, appearing to read "Jack Nigro", is written over a horizontal line.

Jack Nigro, Superintendent  
Buildings and Grounds

JN/esc

Introduced on: March 25, 2014  
Adopted on: March 25, 2014  
Official Resolution#: R20140236

COUNTY OF PASSAIC

DEPARTMENT OF PUBLIC WORKS  
 ENGINEERING DIVISION  
 401 GRAND STREET  
 PATTERSON, NEW JERSEY 07505

CHANGE ORDER # 5  
 PROJECT NUMBER \_\_\_\_\_  
 DATE March 3, 2014

PROJECT TITLE Envelope & Architectural Repairs  
 LOCATION Passaic County Courthouse Complex, Paterson, NJ

3. STATEMENT OF CONTRACT AMOUNT

ORIGINAL CONTRACT AMOUNT.....	\$ 1,570,500.00
PREVIOUS ADDITIONS.....	\$ 293,624.00
TOTAL.....	\$ 1,864,124.00
PREVIOUS DEDUCTIONS.....	\$ 70,003.00
NET PRIOR TO THIS CHANGE.....	\$ 1,786,121.00
AMOUNT OF THIS CHANGE.....	\$ 3,657.00
CONTRACT AMOUNT TO DATE.....	\$ 1,782,464.00

CONTRACTOR'S PROPOSAL FOR THE ABOVE DESCRIBED CHANGES:

I/We hereby agree to the modifications of the contract as described above and agree to furnish all materials, equipment, and labor to perform all work in connection therewith in accordance with the requirements for similar work in the existing contract except as otherwise stipulated therein for the above consideration.

I/We hereby release the County of Passaic, the Board of Chosen Freeholders, their agents, officers and employees from any claims and liability of whatsoever nature for anything done or furnished or in any manner growing out of the performance of the work.

CONTRACTOR Drill Construction Co., Inc.

SIGNATURE *Philip S. Drill* DATE 3/6/2014  
 PHILIP S. DRILL, Chairman of the Board

You are hereby authorized to supply all labor, equipment, and material for the above change as provided under the terms of your contract; all to be in accordance with the plans and specifications and modifications thereof. Your Contract is increased or decreased by the amount given above which is agreed upon.

Reviewed By and Prepared By: *[Signature]* Date \_\_\_\_\_  
 (County Inspector)

Reviewed By and Recommended for Processing By: *[Signature]* Date \_\_\_\_\_  
 (Project Engineer)

Recommend for Approval By: *[Signature]* Date \_\_\_\_\_  
 (County Engineer)

ACCEPTED BY: \_\_\_\_\_ BOARD OF CHOSEN FREEHOLDERS OF PASSAIC COUNTY

SIGNATURE \_\_\_\_\_  
 Freeholder Director

DATE \_\_\_\_\_



COUNTY OF PASSAIC

DEPARTMENT OF PUBLIC WORKS  
 ENGINEERING DIVISION  
 401 GRAND STREET  
 PATERSON, NEW JERSEY 07505

CHANGE ORDER # 5  
 PROJECT NUMBER \_\_\_\_\_  
 DATE 3/3/14

PROJECT TITLE Court House Envelope Project

LOCATION Paterson, N.J.

DATE OF CONTRACT \_\_\_\_\_

OWNER PASSAIC COUNTY BOARD OF CHOSEN FREEHOLDERS

CONTRACTOR Drill Construction

It is hereby mutually agreed that when this Change Order has been signed by the contracting parties the following described changes in work required by contract shall be executed by the Contractor without changing the terms of the contract except as herein stipulated and agreed:

1. DESCRIPTION AND VALUE OF CHANGE

ITEM No.	DESCRIPTION	QUANTITY/UNIT	UNIT PRICE	AMOUNT
DEDUCTIONS				
221	Omit PVC Drain Pipes @ Portico			500.00
222	Omit Caulk @ Administration Plaza			3,157.00
TOTAL DEDUCTIONS				3,657.00

COUNTY OF PASSAIC

DEPARTMENT OF PUBLIC WORKS  
ENGINEERING DIVISION  
401 GRAND STREET  
PATERSON, NEW JERSEY 07505

CHANGE ORDER # 5  
PROJECT NUMBER \_\_\_\_\_  
DATE March 3, 2014

PROJECT TITLE Court House Envelope Project

LOCATION \_\_\_\_\_

1. DESCRIPTION AND VALUE OF CHANGE (Con't)

DEDUCT FROM THE AMOUNT OF CONTRACT.....\$ 3,657.00  
ORIGINAL TIME FOR COMPLETION.....  
ADD TO OR DEDUCT FROM - THE PRESENT CONTRACT TIME..  
NEW DATE FOR COMPLETION IS.....

2. REASON FOR CHANGE

Adjustments as per As-Built Quantities.

# Passaic County Board of Chosen Freeholders

OFFICE OF THE  
PASSAIC COUNTY FREEHOLDERS

Director Pasquale "Pat" Lepore  
Deputy Director Theodore O. Best, Jr.  
John W. Bartlett  
Ronda Casson Cotroneo  
Terry Duffy  
Bruce James  
Hector C. Lora

401 Grand Street  
Paterson, New Jersey 07505  
Tel: 973-881-4402  
Fax: 973-742-3746

Anthony J. De Nova III  
*Administrator*  
William J. Pascrell, III, Esq.  
*County Counsel*  
Louis E. Imhof, III, RMC  
*Clerk Of The Board*



## Public Meeting (Board Meeting)

Date: Mar 25, 2014 - 5:30 PM

Location: County Administration  
220  
401 Grand Street  
Paterson, NJ 07505

Agenda: RESOLUTION AUTHORIZING THE PASSAIC COUNTY PROSECUTOR'S OFFICE TO APPLY FOR STATE FUNDING UNDER THE VICTIMS OF CRIME ACT GRANT NO. V-16-13 FOR A PROJECT IDENTIFIED AS "COUNTY OFFICE OF VICTIMS WITNESS ADVOCACY", ALL AS NOTED IN THE RESOLUTION

THIS RESOLUTION WAS REQUESTED BY:  
PROSECUTOR'S OFFICE

REVIEWED BY:

Anthony J. De Nova III  
COUNTY ADMINISTRATOR

APPROVED AS TO FORM AND LEGALITY:

William J. Pascrell, III, Esq.  
COUNTY COUNSEL

Law and Public Safety

COMMITTEE NAME

<b>Official Resolution#</b>	<b>R20140237</b>						
Meeting Date	03/25/2014						
Introduced Date	03/25/2014						
Adopted Date	03/25/2014						
Agenda Item	I-38						
CAF #	4-01-30-203-001-M01						
Purchase Req. #	TBD						
Result	Adopted						
<b>FREEHOLDER</b>	<b>PRES.</b>	<b>ABS.</b>	<b>MOVE</b>	<b>SEC</b>	<b>AYE</b>	<b>NAY</b>	<b>ABST.</b>
Lepore	✓				✓		
Best Jr	✓		✓		✓		
Bartlett	✓			✓	✓		
Cotroneo	✓				✓		
Duffy	✓				✓		
James	✓				✓		
Lora	✓				✓		

PRES.= present ABS.= absent  
MOVE= moved SEC= seconded  
AYE= yes NAY= no ABST.= abstain

Dated: March 26, 2014

**RESOLUTION AUTHORIZING THE PASSAIC COUNTY  
PROSECUTOR'S OFFICE TO APPLY FOR STATE FUNDING  
UNDER THE VICTIMS OF CRIME ACT GRANT NO. V-16-13  
FOR A PROJECT IDENTIFIED AS "COUNTY OFFICE OF  
VICTIMS WITNESS ADVOCACY"**

**WHEREAS** the State Attorney General has been designated by the Governor to implement the grant programs under the Victims of Crime Act (VOCA), Grant No. V-16-13; and

**WHEREAS** the Passaic County Prosecutor's office wishes to apply for funding for a project named "County Office of Victim Witness Advocacy" for the period of April 1, 2014 through March 31, 2015; and

**WHEREAS** approximately \$ 224,305.00 in VOCA funding is anticipated for the within project, and a \$ 56,076.00 County match is required, for a total project cost of \$ 280,381.00, all as outlined in the attached letter dated from the Office of the Attorney General dated March 4, 2014; and

**WHEREAS** the Freeholder Law and Public Safety Committee has considered this matter at its March 18, 2014 meeting and recommended this resolution to the full Board for adoption; and

**WHEREAS** a certification is attached indicating that funds are available for the required County Match of \$56,076.00;

**NOW THEREFORE IT BE RESOLVED** by the Board of Chosen Freeholders of the County of Passaic that:

- 1) As a matter of policy Passaic County wishes to participate to the fullest extent possible with the Department of Law and Public Safety, Division of Criminal Justice, State Office of Victim-Witness Advocacy.
- 2) The Attorney General will receive funds on behalf of all prospective subgrantees.
- 3) The Division of Criminal Justice shall be responsible for reviewing all applications and making recommendations to the Attorney General for selection of subgrant award recipients.
- 4) The Division of Criminal Justice is authorized to initiate allocations to each subgrantee.
- 5) The Director of the Board and all necessary parties are authorized to sign and execute the application and forms necessary to receive funding under this grant.

Dated: March 25, 2014

CERTIFICATION OF AVAILABLE FUNDS

THIS IS TO CERTIFY THAT FUNDS ARE AVAILABLE AS FOLLOWS:

AMOUNT: \$56,076.00

APPROPRIATION: 4-01-30-203-001-M01

PURPOSE: To provide County match funds for the Passaic County Prosecutor's Office to apply for State Funding under the Victims of Crime Act (VOCA) for a project identified as "County Office of Victims Witness Advocacy."

  
Michael Katz, County Treasurer

DATED: February 25, 2014



*State of New Jersey*  
OFFICE OF THE ATTORNEY GENERAL  
DEPARTMENT OF LAW AND PUBLIC SAFETY  
DIVISION OF CRIMINAL JUSTICE  
PO Box 085  
TRENTON, NJ 08625-0085  
TELEPHONE: (609) 984-6500

CHRIS CHRISTIE  
*Governor*

KIM GUADAGNO  
*Lieutenant Governor*

JOHN J. HOFFMAN  
*Acting Attorney General*

ELIE HONIG  
*Director*

March 4, 2014

Honorable Camelia M. Valdes, Prosecutor  
Passaic County Prosecutor's Office  
401 Grand Street  
Paterson, New Jersey 07505

Re: Victims of Crime Act (VOCA) Grant Program  
Project Title: County Office of Victim Witness Advocacy  
Subgrant Number: V-16-13

Dear Prosecutor Valdes:

The Division of Criminal Justice is accepting applications for the Victims of Crime Act (VOCA) Grant Program to support funding for the Passaic County Office of Victim Witness Advocacy.

Your federal grant will be in the amount of \$224,305. Matching funds in the amount of \$56,076 are required. The total amount of the grant project will be \$280,381.

The current grant is scheduled to end on March 31, 2014. It is projected that your continuation award will run from April 1, 2014 to March 31, 2015. Approval for expenditures for the grant cannot be authorized until a fully executed subgrant award/contract is completed. All required reports for your previous grant must be current and on file with the State Office of Victim Witness Advocacy (SOVWA) prior to the start of your continuation grant.

An application package has been e-mailed to Joan Nixon, Victim Witness Coordinator. The completed application, including the required Freeholder Resolution and grant certifications, should be submitted to the SOVWA by April 4, 2014.



For further assistance in preparing your application or if you have any questions, please contact Isaac Junius, Program Analyst at (609) 984-1039.

Very truly yours,

Alyson M. Gush, Chief  
State Office of Victim Witness Advocacy

c: Joan Nixon , Victim Witness Coordinator  
Todd Stanley, Chief Financial Officer  
Isaac Junius, DCJ Program Analyst  
Marilyn Easley, SOVWA



# Passaic County Board of Chosen Freeholders

OFFICE OF THE  
PASSAIC COUNTY FREEHOLDERS

Director Pasquale "Pat" Lepore  
Deputy Director Theodore O. Best, Jr.  
John W. Bartlett  
Ronda Casson Cotroneo  
Terry Duffy  
Bruce James  
Hector C. Lora

401 Grand Street  
Paterson, New Jersey 07505

Tel: 973-881-4402  
Fax: 973-742-3746

Anthony J. De Nova III

Administrator

William J. Pascrell, III, Esq.

County Counsel

Louis E. Imhof, III, RMC

Clerk Of The Board



## Public Meeting (Board Meeting)

Date: Mar 25, 2014 - 5:30 PM

Location: County Administration  
220  
401 Grand Street  
Paterson, NJ 07505

Agenda: RESOLUTION AUTHORIZING PURCHASE OF VARIOUS ITEMS BY THE PASSAIC COUNTY PROSECUTOR'S OFFICE, ALL AS NOTED IN THE RESOLUTION

THIS RESOLUTION WAS REQUESTED BY:  
PROSECUTOR'S OFFICE

REVIEWED BY:

  
Anthony J. De Nova III  
COUNTY ADMINISTRATOR

APPROVED AS TO FORM AND LEGALITY:

  
William J. Pascrell, III, Esq.  
COUNTY COUNSEL

Law and Public Safety  
COMMITTEE NAME

<b>Official Resolution#</b>	<b>R20140238</b>						
Meeting Date	03/25/2014						
Introduced Date	03/25/2014						
Adopted Date	03/25/2014						
Agenda Item	I-39						
CAF #	T-23-56-850-000-801						
Purchase Req. #	r4-02422						
Result	Adopted						
<b>FREEHOLDER</b>	<b>PRES.</b>	<b>ABS.</b>	<b>MOVE</b>	<b>SEC</b>	<b>AYE</b>	<b>NAY</b>	<b>ABST.</b>
Lepore	✓				✓		
Best Jr	✓		✓		✓		
Bartlett	✓			✓	✓		
Cotroneo	✓				✓		
Duffy	✓				✓		
James	✓				✓		
Lora	✓				✓		

PRES.= present ABS.= absent  
MOVE= moved SEC= seconded  
AYE= yes NAY= no ABST.= abstain

Dated: March 26, 2014

**RESOLUTION AUTHORIZING PURCHASE OF VARIOUS ITEMS BY  
THE PASSAIC COUNTY PROSECUTOR'S OFFICE**

**WHEREAS** the Passaic County Prosecutor's Office (the "PCPO") has requested the purchase of various goods and services from qualified vendors for use in furtherance of its law enforcement and/or administrative objectives and/or those of various law enforcement agencies within the County; and

**WHEREAS** said goods and services are being procured either through State Contract, Cooperative Purchasing Agreements and/or Federal GSA Schedules or other methods permitted by the Local Public Contracts Law, N.J.S.A. 40A:11-1, et seq., as specified below; and

**WHEREAS** said purchases are to be funded either directly from the County budget or from forfeited funds obtained by the PCPO and/or administered by the PCPO on behalf of the Passaic County Sheriff's Department and/or local law enforcement agencies in accordance with applicable law; and

**WHEREAS** the Board of Chosen Freeholders is desirous of approving said purchases in accordance with the terms of the applicable contracts and authorizing the Purchasing Agent to issue the appropriate Purchase Orders; and

**WHEREAS** the Freeholder Law and Public Safety Committee has considered this matter and recommended this resolution to the full Board for adoption; and

**WHEREAS** a certification is attached indicating that funds are available for the within contemplated expenditures; and

**NOW THEREFORE BE IT RESOLVED** by the Board of Chosen Freeholders of the County of Passaic that it hereby authorizes the purchase of the following goods and/or services in accordance with the terms of the applicable State Contract, Cooperative Purchasing Agreements, Federal GSA Schedules or other authorized contracts:

Description:	Purchase of computer software
Using Agency:	Passaic County Prosecutor's Office
Purchase Price:	\$12,210.00
Vendor:	SHI
Authority:	NJ State Contract
Contract #:	77560
Account:	Prosecutor's Local Forfeiture Account
Account #:	T-23-56-850-000-801
Requisition #:	R4-02422

**BE IT FURTHER RESOLVED** that the Purchasing Agent and all other necessary officers and employees be and hereby are authorized and directed to take such further actions and sign such documents as are necessary to effectuate the purpose of this resolution, including but not limited to issuance of appropriate Purchase Order.

Dated: March 25, 2014

CERTIFICATION OF AVAILABLE FUNDS

THIS IS TO CERTIFY THAT FUNDS ARE AVAILABLE AS FOLLOWS:

AMOUNT: \$12,210.00

APPROPRIATION: T-23-56-850-000-801

PURPOSE: To authorize the purchase of computer software from SHI by the Passaic County Prosecutor's Office.

  
Michael Katz, County Treasurer

DATED: February 25, 2014

**COUNTY OF PASSAIC**  
 CO OF PASSAIC, (Q)973-837-7675  
 PROSECUTOR'S OFFICE-T.STANLEY  
 401 GRAND STREET - 7TH FLOOR  
 PATERSON, NJ 07505

REQUISITION	<b>Res Pg:1.39-5</b>
NO.	R4-02422

S H I P  T O	SGT. JOE RIZZO PROSECUTOR'S OFFICE 30 KING ROAD TOTOWA, NJ 07512
V E N D O R	VENDOR #: 08638  SHI 290 DAVIDSON AVENUE SOMERSET, NJ 08873

ORDER DATE: 03/13/14  
 DELIVERY DATE:  
 STATE CONTRACT: 77560  
 F.O.B. TERMS:

QTY/UNIT	DESCRIPTION	ACCOUNT NO.	UNIT PRICE	TOTAL COST
100.00/EA	BlueZone Emulator - Per Seat License Rocket Software, Inc. Part#: BLU-EMUL-LP-300	T-23-56-850-000-801	101.7500	10,175.00
100.00/EA	BlueZone Emulator - Per Seat Maintenance - Rocket Software, Inc. Part#: BLU-EMUL-MS-300  as per quotation # 7664926 created February 20, 2014  Promis Gavel SSL Conversion  Prosecutor Local Forfeiture Account  RESO 2014-0112 2-25-2014	T-23-56-850-000-801	20.3500	2,035.00
			TOTAL	12,210.00

Introduced on: March 25, 2014  
 Adopted on: March 25, 2014  
 Official Resolution#: R20140238

\_\_\_\_\_  
 REQUESTING DEPARTMENT

\_\_\_\_\_  
 DATE

CERTIFICATION OF AVAILABLE FUNDS

THIS IS TO CERTIFY THAT FUNDS ARE AVAILABLE AS FOLLOWS:

AMOUNT: \$622,344.68

APPROPRIATION: \$ 21,631.38 – G-01-41-846-012-223  
\$ 18,963.20 – G-01-41-846-012-223  
\$199,295.00 – G-01-41-846-013-223  
\$345,650.00 – G-01-41-846-011-223  
\$ 2,593.50 – G-01-41-846-011-223  
\$ 34,211.60 – G-01-41-846-011-223

PURPOSE: To authorize the purchase of various items by the Passaic County Office of Emergency Management.

  
Michael Katz, County Treasurer

DATED: February 25, 2014

**COUNTY OF PASSAIC**  
 CO OF PASSAIC, EMERGENCY MNGT  
 (Q) 973-904-3631  
 300 OLDHAM ROAD  
 WAYNE, NJ 07470-2209

REQUISITION <b>Res-Pg:1.40-7</b>	
NO.	R4-02433

SHIP TO	Det. Chris Whiting 30 King Road Totowa, N.J. 07512
VENDOR	VENDOR #: 07479 CDW GOVERNMENT, INC. 230 N. MILWAUKEE AVENUE VERNON HILLS, IL 60061

ORDER DATE: 03/14/14  
 DELIVERY DATE:  
 STATE CONTRACT:  
 F.O.B. TERMS:

QTY/UNIT	DESCRIPTION	ACCOUNT NO.	UNIT PRICE	TOTAL COST
2.00	VMWARE VSPH W/OPS MGMT ENT+P Catalog #: 3137914	G-01-41-846-012-223	3,603.5200	7,207.04
2.00	VMWARE VSPHERE 5 STD 1P Catalog #: 2471492	G-01-41-846-012-223	840.0000	1,680.00
2.00	VMWARE VSPH W/OPS MGMT ENT+3Y BSNS Catalog #: 3137926	G-01-41-846-012-223	2,246.3800	4,492.76
2.00	VMWARE VSPHERE 5 STD 1P 3Y BSN Catalog #: 2471873	G-01-41-846-012-223	688.2900	1,376.58
1.00	VMWARE VCENTER SRV 5 STD Catalog #: 2471461	G-01-41-846-012-223	4,225.0000	4,225.00
1.00	VMWARE VCTR SRV 5 STD VSPH5 3Y BSNS CATALOG # 2471703	G-01-41-846-012-223	2,650.0000	2,650.00
	AS PRE QUOTE # FCZL854 CONTRACT: MRESC CO-OP #65MCECCPS  FY-12 UASI HOMELAND SECURITY GRANT			
			TOTAL	21,631.38

Introduced on: March 25, 2014  
 Adopted on: March 25, 2014  
 Official Resolution#: R20140239

REQUESTING DEPARTMENT

DATE

**COUNTY OF PASSAIC**  
 CO OF PASSAIC, EMERGENCY MNGT  
 (Q) 973-904-3631  
 300 OLDHAM ROAD  
 WAYNE, NJ 07470-2209

REQUISITION	
NO.	R4-02425

SHIP TO	DET. CHRIS WHITING 30 KING ROAD TOTOWA, N.J. 07512
VENDOR	VENDOR #: 07479 CDW GOVERNMENT, INC. 230 N. MILWAUKEE AVENUE VERNON HILLS, IL 60061

ORDER DATE: 03/13/14  
 DELIVERY DATE:  
 STATE CONTRACT: 70262  
 F.O.B. TERMS:

QTY/UNIT	DESCRIPTION	ACCOUNT NO.	UNIT PRICE	TOTAL COST
1.00	HP SB DL380 GEN8 E7-4830V2 SRV 2X10 CORE INTEL E7-4890V2.2GHZ 20MB CACHE 105W PROCESSORS, 4HP MEMORY BOARDS 64GB 8GBX8 1RX4 PC3-14900R-13 KIT, 10 BAY DRIVE CAGE, NETWORK CARD 1GB 4 PORTS, TWO 1200 W POWER SUPPLIES, HP ILO 4U RK MNTG BB GEN KIT, 3 YEAR LABOR 3/3/3 Catalog #: 3269250	G-01-41-846-012-223	10,950.0000	10,950.00
2.00	HP ENET 10GB 2-PORT 530SFP ADA Catalog #: 2743158	G-01-41-846-012-223	510.0000	1,020.00
2.00	HP 146GB 6G SAS 15K SFF Catalog #: 2743158	G-01-41-846-012-223	235.0000	470.00
4.00	HP BLC 10GB SR SFP +OPT Catalog #: 1633034	G-01-41-846-012-223	580.0000	2,320.00
1.00	HPE 5YR 24X7X4 DMR DL58X CATALOG # 1265014	G-01-41-846-012-223	4,203.2000	4,203.20
	AS PRE QUOTE # FCVV031 STATE CONTRACT # 70262 wsca  FY-12 UASI HOMELAND SECURITY GRANT			
			TOTAL	18,963.20

Introduced on: March 25, 2014  
 Adopted on: March 25, 2014  
 Official Resolution#: R20140239

REQUESTING DEPARTMENT

DATE



COUNTY OF PASSAIC  
 CO OF PASSAIC, EMERGENCY MNGT  
 (Q) 973-904-3631  
 300 OLDHAM ROAD  
 WAYNE, NJ 07470-2209

REQUISITION	
Res-Pg:1.40-9	
NO.	R4-02238

S H I P  T O	DET. CHRIS WHITING 30 KING ROAD TOTOWA, N.J. 07512
	VENDOR #: 07479
V E N D O R	CDW GOVERNMENT, INC. 230 N. MILWAUKEE AVENUE VERNON HILLS, IL 60061

ORDER DATE: 03/11/14  
 DELIVERY DATE:  
 STATE CONTRACT:  
 F.O.B. TERMS:

QTY/UNIT	DESCRIPTION	ACCOUNT NO.	UNIT PRICE	TOTAL COST
1.00	SOURCEFIRE SF 8140 ADV MW PROT CATALOG # SUB-3D8140-AMP-1-0-A	G-01-41-846-013-223	9,750.0000	9,750.00
8.00	SOURCEFIRE FIRESIGHT LIC F/VIRT BND CATALOG # S-VDC-64BIT-VMWARE-BNDL-0-P	G-01-41-846-013-223	1,300.0000	10,400.00
1.00	SOURCEFIRE 3D7125 NEXT GEN FW 1U CATALOG # 3D7125-NGFW-CO4-SFP	G-01-41-846-013-223	18,200.0000	18,200.00
5.00	SOURCEFIRE PLAT SUP SF 3D7125 CATALOG # S-3D7125-NGFW-CO4-SFP-P	G-01-41-846-013-223	6,990.0000	34,950.00
5.00	SOURCEFIRE SF 3D7125 MW PROT CATALOG # SUB-3D7125-AMP-1-0-A	G-01-41-846-013-223	3,375.0000	16,875.00
4.00	SOURCEFIRE 4PT FIB SR10GBPS NT Catalog # NM-SR4-FW-0	G-01-41-846-013-223	10,950.0000	43,800.00
20.00	SOURCEFIRE SUPPORT 4 PORT FIBER SR CATALOG # S-NM-SR4-FW-0-P	G-01-41-846-013-223	2,900.0000	58,000.00
2.00	SOURCEFIRE DEF CTR 64 BIT VMWARE BUN CATALOG # VDC-64BIT-VMWARE-BNDL-0	G-01-41-846-013-223	3,660.0000	7,320.00
	As pre Quote # FBVB209 MRESC CO-OP # 65MCESCCPS  FY-13 UASI Homeland Security Grant			
			TOTAL	199,295.00

Introduced on: March 25, 2014  
 Adopted on: March 25, 2014  
 Official Resolution#: R20140239

REQUESTING DEPARTMENT \_\_\_\_\_ DATE \_\_\_\_\_

**COUNTY OF PASSAIC**  
 CO OF PASSAIC, EMERGENCY MNGT  
 (Q) 973-904-3631  
 300 OLDHAM ROAD  
 WAYNE, NJ 07470-2209

REQUISITION	
NO.	R4-02236

S H I P  T O  V E N D O R	Det. Chris Whiting 30 King Road Totowa, N.J. 07512
	VENDOR #: 07479
	CDW GOVERNMENT, INC. 230 N. MILWAUKEE AVENUE VERNON HILLS, IL 60061

ORDER DATE: 03/11/14  
 DELIVERY DATE:  
 STATE CONTRACT:  
 F.O.B. TERMS:

QTY/UNIT	DESCRIPTION	ACCOUNT NO.	UNIT PRICE	TOTAL COST
2.00	Sourcefire SF 3D8140 FW 1U 3 SLOT Catalog # 3D8140-NGFW-000-CHAS	G-01-41-846-011-223	52,650.0000	105,300.00
10.00	Sourcefire Support-3d8140 3 slots CATALOG # S-3D8140-NGFW-000-CHAS-P	G-01-41-846-011-223	15,000.0000	150,000.00
9.00	Sourcefire SF 8140 ADV MW PROT CATALOG # SUB-3D8140-AMP-1-0-A	G-01-41-846-011-223	9,750.0000	87,750.00
2.00	Sourcefire Firesight Lic F/VIRT BND Catalog # SVDC-64BIT-VMWARE-BNDL-0-P  As Pre Quote # FBVB209  MRESC CO-OP # 65MCESCCPS  FY-11 UASI Homeland Security Grant	G-01-41-846-011-223	1,300.0000	2,600.00
			TOTAL	345,650.00

Introduced on: March 25, 2014  
 Adopted on: March 25, 2014  
 Official Resolution#: R20140239

REQUESTING DEPARTMENT

DATE

**COUNTY OF PASSAIC**  
 CO OF PASSAIC, EMERGENCY MNGT  
 (Q) 973-904-3631  
 300 OLDHAM ROAD  
 WAYNE, NJ 07470-2209

REQUISITION	
Res Pg: 1.40-11	
NO.	R4-02328

S H I P  T O	Det. Chris Whiting 30 King Road Totawa, N.J. 07512
	V E N D O R

ORDER DATE: 03/13/14  
 DELIVERY DATE:  
 STATE CONTRACT:  
 F.O.B. TERMS:

QTY/UNIT	DESCRIPTION	ACCOUNT NO.	UNIT PRICE	TOTAL COST
2.00	10 BASE-SR X2 MODULE CATALOG # X2-10GB-SR  AS PRE QUOTE 3/12/2014 GSA CONTRACT # GS-35F-0220R  FY-11 HOMELAND SECURITY GRANT	G-01-41-846-011-223	1,296.7500	2,593.50
			TOTAL	2,593.50

Introduced on: March 25, 2014  
 Adopted on: March 25, 2014  
 Official Resolution#: R20140239

\_\_\_\_\_  
 REQUESTING DEPARTMENT

\_\_\_\_\_  
 DATE

**COUNTY OF PASSAIC**  
 CO OF PASSAIC, EMERGENCY MNGT  
 (Q) 973-904-3631  
 300 OLDHAM ROAD  
 WAYNE, NJ 07470-2209

REQUISITION	
NO.	R4-02326

S H I P  T O  V E N D O R	Det. Chris Whiting 30 King Road Totowa, New Jersey 07512
	VENDOR #: 10819 TEQUIPMENT, INC. 7 NORDEN LANE HUNINGTON STATION, NY 11746

ORDER DATE: 03/13/14  
 DELIVERY DATE:  
 STATE CONTRACT: T0114  
 F.O.B. TERMS:

QTY/UNIT	DESCRIPTION	ACCOUNT NO.	UNIT PRICE	TOTAL COST
1.00	SMART BOARD 885/MEETING PRO Catalog #: SB885-SMP	G-01-41-846-011-223	5,499.0000	5,499.00
1.00	UX80 RETROFIT KIT FOR EXISTING SB885 INSTALLATION Catalog #: UX80-SB885	G-01-41-846-011-223	1,999.0000	1,999.00
1.00	EXTENDED CABLE KIT Catalog #: CBLKITE	G-01-41-846-011-223	319.2000	319.20
1.00	BRIDGIT SERVER MAX 500 USERS Catalog #: BSS-MAX	G-01-41-846-011-223	7,999.0000	7,999.00
1.00	SMART PODIUM 500 SERIES Catalog #: SP524-MP	G-01-41-846-011-223	3,999.0000	3,999.00
1.00	CONNECTION KIT/INTEGRATED UNIT Catalog #: CBLKITE	G-01-41-846-011-223	159.2000	159.20
1.00	ULTIMATE 111 CLASSROOM SYSTEM PAL - 4 CEILING SPEAKERS Catalog #: 1000-0706	G-01-41-846-011-223	1,795.0000	1,795.00
1.00	SAFE COMMANDER HEAD KIT Catalog #: 3000-0455	G-01-41-846-011-223	6,250.0000	6,250.00
3.00	PTZ CAMERA KIT Catalog #: KIT-1000-0815	G-01-41-846-011-223	1,491.0000	4,473.00
1.00	EXTENDED CABLE KIT Catalog #: CBLKITE	G-01-41-846-011-223	319.2000	319.20
1.00	INSTALLATION OF 800I UX80 PROJECTOR SYSTEM WITH ADDITIONAL ITEMS AS LISTED Catalog #: INST-TEQ-800IX2	G-01-41-846-011-223	850.0000	850.00

Introduced on: March 26, 2014  
 Adopted on: March 26, 2014  
 Official Resolution#: R20140239

REQUESTING DEPARTMENT

DATE

COUNTY OF PASSAIC  
 CO OF PASSAIC, EMERGENCY MNGT  
 (Q) 973-904-3631  
 300 OLDHAM ROAD  
 WAYNE, NJ 07470-2209

REQUISITION	
Res Pg: 1.40-13	
NO.	R4-02326

Page # 2

QTY/UNIT	DESCRIPTION	ACCOUNT NO.	UNIT PRICE	TOTAL COST
1.00	INSTALLATION OF CUSTOMIZED ITEMS CATALOG # INST-BC-CUSTOM  AS PRE QUOTE # 82407 STATE CONTRACT # 10114  FY-11 UASI HOMELAND SECURITY GRANT	G-01-41-846-011-223	550.0000	550.00
			TOTAL	34,211.60
<p>Introduced on: March 25, 2014          Adopted on: March 25, 2014          Official Resolution#: R20140239</p>				

# Passaic County Board of Chosen Freeholders

OFFICE OF THE  
PASSAIC COUNTY FREEHOLDERS

Director Pasquale "Pat" Lepore  
Deputy Director Theodore O. Best, Jr.  
John W. Bartlett  
Ronda Casson Cotroneo  
Terry Duffy  
Bruce James  
Hector C. Lora

401 Grand Street  
Paterson, New Jersey 07505

Tel: 973-881-4402  
Fax: 973-742-3746

Anthony J. De Nova III

Administrator

William J. Pascrell, III, Esq.

County Counsel

Louis E. Imhof, III, RMC

Clerk Of The Board



## Public Meeting (Board Meeting)

Date: Mar 25, 2014 - 5:30 PM

Location: County Administration  
220  
401 Grand Street  
Paterson, NJ 07505

Agenda: RESOLUTION AUTHORIZING PURCHASE OF VARIOUS ITEMS BY THE PASSAIC COUNTY OFFICE OF EMERGENCY MANAGEMENT, ALL AS NOTED IN THE RESOLUTION

THIS RESOLUTION WAS REQUESTED BY:  
OFFICE OF EMERGENCY MANAGEMENT

REVIEWED BY:

Anthony J. De Nova III  
COUNTY ADMINISTRATOR

APPROVED AS TO FORM AND LEGALITY:

William J. Pascrell, III, Esq.  
COUNTY COUNSEL

Law and Public Safety

COMMITTEE NAME

<b>Official Resolution#</b>	<b>R20140239</b>						
Meeting Date	03/25/2014						
Introduced Date	03/25/2014						
Adopted Date	03/25/2014						
Agenda Item	I-40						
CAF #	G-01-41-011/012/013-						
Purchase Req. #	R4-02433;R4-02425;R4-02238;R4-02236;R4-02328;R4-02326						
Result	Adopted						
<b>FREEHOLDER</b>	<b>PRES.</b>	<b>ABS.</b>	<b>MOVE</b>	<b>SEC</b>	<b>AYE</b>	<b>NAY</b>	<b>ABST.</b>
Lepore	✓				✓		
Best Jr	✓		✓		✓		
Bartlett	✓			✓	✓		
Cotroneo	✓				✓		
Duffy	✓				✓		
James	✓				✓		
Lora	✓				✓		

PRES.= present ABS.= absent  
MOVE= moved SEC= seconded  
AYE= yes NAY= no ABST.= abstain

**RESOLUTION AUTHORIZING PURCHASE OF VARIOUS ITEMS  
BY THE PASSAIC COUNTY OFFICE OF EMERGENCY  
MANAGEMENT**

**WHEREAS** the Passaic County Office of Emergency Management has requested the purchase of various goods and services from qualified vendors for use in furtherance of Homeland Security and Preparedness efforts within the County; and

**WHEREAS** said goods and services are being procured either through State Contract, Cooperative Purchasing Agreements and/or Federal GSA Schedules or other methods permitted by the Local Public Contracts Law, N.J.S.A. 40A:11-1, et seq., as specified below; and

**WHEREAS** said purchases are to be funded directly from Homeland Security and Preparedness Grants. and

**WHEREAS** the Board of Chosen Freeholders is desirous of approving said purchases in accordance with the terms of the applicable contracts and authorizing the Purchasing Agent to issue the appropriate Purchase Orders; and

**WHEREAS** the Law and Public Safety Committee has considered this matter and recommended this resolution to the full Board for adoption; and

**WHEREAS** a certification is attached indicating that funds are available for the within contemplated expenditures; and

**NOW THEREFORE BE IT RESOLVED** by the Board of Chosen Freeholders of the County of Passaic that it hereby authorizes the purchase of the following goods and/or services in accordance with the terms of the applicable State Contract, Cooperative Purchasing Agreements, Federal GSA Schedules or other authorized contracts:

Description:	VM Ware Computer Equipment
Using Agency:	Passaic County Prosecutor's Office
Purchase Price:	\$21,631.38
Vendor:	CDW Government (#07479)
Authority:	MRESC CO-OP Contract
Contract #:	65MCESCCPS
Account:	Homeland Security & Preparedness Grant
Account #:	G-01-41-846-012-223
Requisition #:	R4-02433



Description: HP Computer Equipment  
 Using Agency: Passaic County Prosecutor's Office  
 Purchase Price: \$18,963.20  
 Vendor: CDW Government (#07479)  
 Authority: New Jersey State Contract  
 Contract #: 70262  
 Account: Homeland Security & Preparedness Grant  
 Account #: G-01-41-846-012-223  
 Requisition #: R4-02425

Description: Sourcefire Computer Equipment  
 Using Agency: Passaic County Prosecutor's Office  
 Purchase Price: \$199,295.00  
 Vendor: CDW Government (#07479)  
 Authority: MRESC CO-OP Contract  
 Contract #: 65MCESCCPS  
 Account: Homeland Security & Preparedness Grant  
 Account #: G-01-41-846-013-223  
 Requisition #: R4-02238

Description: Sourcefire Computer Equipment  
 Using Agency: Passaic County Prosecutor's Office  
 Purchase Price: \$345,650.00  
 Vendor: CDW Government (#07479)  
 Authority: MRESC CO-OP Contract  
 Contract #: 65MCESCCPS  
 Account: Homeland Security & Preparedness Grant  
 Account #: G-01-41-846-011-223  
 Requisition #: R4-02236

Description: 10 Base-SR Module Computer Equipment  
 Using Agency: Passaic County Prosecutor's Office  
 Purchase Price: \$2,593.50  
 Vendor: Millennium Communications (#01361)  
 Authority: GSA Contract  
 Contract #: #GS-35F-0220R  
 Account: Homeland Security & Preparedness Grant  
 Account #: G-01-41-846-011-223  
 Requisition #: R4-02328

Description: Smart Board  
 Using Agency: Passaic County Prosecutor's Office  
 Purchase Price: \$34,211.60  
 Vendor: Tequipment (#10819)  
 Authority: New Jersey State Contract  
 Contract #: T0114  
 Account: Homeland Security & Preparedness Grant  
 Account #: G-01-41-846-011-223  
 Requisition #: R4-02326

**BE IT FURTHER RESOLVED** that the Purchasing Agent and all other necessary officers and employees be and hereby are authorized and directed to take such further actions and sign such documents as are necessary to effectuate the purpose of this resolution, including but not limited to issuance of appropriate Purchase Orders.

Dated: March 25, 2014

# Passaic County Board of Chosen Freeholders

OFFICE OF THE  
PASSAIC COUNTY FREEHOLDERS

Director Pasquale "Pat" Lepore  
Deputy Director Theodore O. Best, Jr.  
John W. Bartlett  
Ronda Casson Cotroneo  
Terry Duffy  
Bruce James  
Hector C. Lora

401 Grand Street  
Paterson, New Jersey 07505

Tel: 973-881-4402  
Fax: 973-742-3746

Anthony J. De Nova III

Administrator

William J. Pascrell, III, Esq.

County Counsel

Louis E. Imhof, III, RMC

Clerk Of The Board



## Public Meeting (Board Meeting)

Date: Mar 25, 2014 - 5:30 PM

Location: County Administration  
220  
401 Grand Street  
Paterson, NJ 07505

Agenda: RESOLUTION AUTHORIZING THE EXECUTION OF A GRANTEE-SUBGRANTEE AGREEMENT BETWEEN THE COUNTY OF PASSAIC AND THE STATE OF NEW JERSEY OFFICE OF THE ATTORNEY GENERAL DEPARTMENT OF LAW AND PUBLIC SAFETY FOR THE PASSAIC COUNTY MULTI-JURISDICTIONAL HAZARD MITIGATION PLAN UPDATE, ALL AS NOTED IN THE RESOLUTION

THIS RESOLUTION WAS REQUESTED BY:

OFFICE OF EMERGENCY MANAGEMENT

REVIEWED BY:

Anthony J. De Nova III  
COUNTY ADMINISTRATOR

APPROVED AS TO FORM AND LEGALITY:

William J. Pascrell, III, Esq.  
COUNTY COUNSEL

Law and Public Safety

COMMITTEE NAME

Official Resolution#		R20140240						
Meeting Date		03/25/2014						
Introduced Date		03/25/2014						
Adopted Date		03/25/2014						
Agenda Item		I-41						
CAF #								
Purchase Req. #								
Result		Adopted						
FREEHOLDER	PRES.	ABS.	MOVE	SEC	AYE	NAY	ABST.	
Lepore	✓				✓			
Best Jr	✓		✓		✓			
Bartlett	✓			✓	✓			
Cotroneo	✓				✓			
Duffy	✓				✓			
James	✓				✓			
Lora	✓				✓			

PRES.= present ABS.= absent  
MOVE= moved SEC= seconded  
AYE= yes NAY= no ABST.= abstain

Dated: March 26, 2014

**RESOLUTION AUTHORIZING THE EXECUTION OF A  
GRANTEE-SUBGRANTEE AGREEMENT BETWEEN THE  
COUNTY OF PASSAIC AND THE STATE OF NEW JERSEY  
OFFICE OF THE ATTORNEY GENERAL DEPARTMENT OF  
LAW AND PUBLIC SAFETY FOR THE PASSAIC COUNTY  
MULTI-JURISDICTIONAL HAZARD MITIGATION PLAN  
UPDATE**

**WHEREAS** the Passaic County Office of Emergency Management has received notification from the State of New Jersey Office of the Attorney General Department of Law and Public Safety, Division of State Police, that the County's application for Federal assistance under the Hazard Mitigation Grant Program has been approved by the Federal Emergency Management Agency for the Passaic County Multi-jurisdictional Hazard Mitigation Plan Update (see letter dated February 9, 2014 attached); and

**WHEREAS** the County of Passaic is eligible to receive grant funds in the amount of \$250,000.00, of which \$187,500.00 is Federal cash funds, and the remaining \$62,500.00 is an in-kind services County match; and

**WHEREAS** the Freeholder Law and Public Safety Committee considered this matter at its March 18, 2014 meeting, and recommends it to the full Board for approval; and

**WHEREAS** the Board of Chosen Freeholders of the County of Passaic is desirous of formally accepting the funding award and authorizing the execution of a Grantee-Subgrantee Agreement as it

concerns the County's Multi-jurisdictional Hazard Mitigation Plan Update;

**NOW THEREFORE BE IT RESOLVED** by the Board of Chosen Freeholders of the County of Passaic that, pursuant to the terms and conditions set forth above, it hereby formally accepts the above-referenced grant award on behalf of the County of Passaic; and

**BE IT FURTHER RESOLVED** that all required Passaic County Officers and employees be authorized to execute the Grantee-Subgrantee Agreement as it concerns the Passaic County Hazard Mitigation Plan Update, in order to effectuate the terms of this resolution.

Dated: March 25, 2014



**State of New Jersey**  
 OFFICE OF THE ATTORNEY GENERAL  
 DEPARTMENT OF LAW AND PUBLIC SAFETY  
 DIVISION OF STATE POLICE  
 POST OFFICE BOX 7068  
 WEST TRENTON, NJ 08628-0068  
 (609) 882-2000

CHRIS CHRISTIE  
*Governor*

KIM GUADAGNO  
*Lt. Governor*

JOHN J. HOFFMAN  
*Acting Attorney General*

COLONEL JOSEPH R. FUENTES  
*Superintendent*

February 9, 2014

Mr. Robert A. Lyons, Director  
 Passaic County OEM  
 300 Oldham Road  
 Wayne, New Jersey 07470

**SUBJECT:** Approval and Funding  
 Passaic County Multi-jurisdictional Hazard Mitigation Plan Update  
 FEMA Project # HMGP-DR-4086-009

Dear Mr. Lyons:

On behalf of Governor Chris Christie, I am pleased to inform you that your application for Federal assistance under the Hazard Mitigation Grant Program was approved by the Federal Emergency Management Agency (FEMA) on December 18, 2013 for the above referenced project. The approved funding for eligible project activities is as follows:

Federal Share (75%)	\$187,500.00
Non-Federal Share (25%)	<u>62,500.00</u>
<b>TOTAL PROJECT AWARD</b>	<b>\$250,000.00</b>

A Sub-grantee Agreement briefing meeting is required for this grant award, prior to project implementation. At this meeting the following information will be explained to you and members of your staff:

- Project Performance Period (POP) (December 18, 2013 – December 17, 2016)
- Reporting Requirements
- Procurement Process
- Reimbursement Request Process

Please note that the POP under this award is for the Plan Update only and does not extend or supersede the expiration date of Passaic County's current Multi-jurisdictional Hazard Mitigation Plan, which is set to expire on August 12, 2015.

Introduced on: Mar  
 Adopted on: Mar  
 Official Resolution#: R2



"An Internationally Accredited Agency"

*New Jersey Is An Equal Opportunity Employer  
 Printed on Recycled Paper and Recyclable*



Chris Testa, the Mitigation Unit Manager, will be contacting you soon to schedule the Sub-grantee Agreement briefing meeting.

If you should have any questions, please contact Chris Testa at (609) 508-6557 or via email [lpptestc@gw.njsp.org](mailto:lpptestc@gw.njsp.org).

Sincerely,

**FOR COLONEL JOSEPH R. FUENTES  
SUPERINTENDENT**

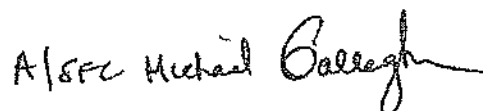

Michael Gallagher, A/SFC  
State Hazard Mitigation Officer  
NJ Office of Emergency Management

Enclosures:

- 1) State Approval Letter
- 2) Sub-grantee Agreement
- 3) Blank Quarterly Report
- 4) Blank Reimbursement Form
- 5) Blank Procurement Process Competitive Proposals Checklist

**GRANTEE-SUBGRANTEE AGREEMENT  
HAZARD MITIGATION GRANT PROGRAM (CDFA#97.039)  
FEMA-4086**

This Grant Agreement (the "Agreement") is made and entered into by, and between, the State of New Jersey, Office of Emergency Management, located at PO Box 7068, West Trenton, New Jersey 08628 (herein referred to as the "Grantee"); and, the County of Passaic Office of Emergency Management, located at 300 Oldham Road, Wayne, New Jersey 07470-2209 (herein referred to as the "Sub-grantee").

This agreement will be in effect for the period beginning December 18, 2013 and ending December, 172016.

1. Pursuant to the provisions of The Robert T. Stafford Disaster Relief and Emergency Assistance Act, Public Law 93-288, as amended ("The Stafford Act"), identifies the use of disaster relief funds under Section 404 (Hazard Mitigation Grant Program, "HMGP") for a variety of hazard mitigation activities, including hazard mitigation planning.
2. The New Jersey Office of Emergency Management has been designated as the Grantee to receive, administer, and disburse FEMA funds for cost-effective mitigation planning activities in areas of New Jersey.
3. The County of Passaic Office of Emergency Management is the Sub-grantee and has submitted an application, which is incorporated herein by reference, setting forth a list of activities (here referred to as "the Project"). The Sub-grantee agrees that the sub-grant award must result in a multi-jurisdictional multi-hazard mitigation plan update adopted by the jurisdiction and approved by FEMA that satisfies the requirements of 44 C.F.R. Part 201 prior to end of the period of performance.
4. The Sub-grantee shall participate in the development of, and shall coordinate and monitor the implementation of the local hazard mitigation plan measures.
5. The Sub-grantee has the legal authority to accept mitigation funds and shall provide all necessary financial and managerial resources to meet the terms and conditions of receiving federal and state mitigation funds. The financial management system must comply with 44 Code of Federal Regulations (CFR) Part 13 and OMB Circular A-87. The Sub-Grantee shall adhere to 44 CFR Part 14 - Administration of Grants: Audits of State and Local Governments.
6. The Sub-grantee shall use the funds solely for the approved scope of work in the Project. Only those costs, which are allowable as defined in 44 CFR Part 13, Part 206 and OMB Circular A-87, will be paid.
  - a. This Grant Agreement in the amount of ~~\$250,000.00~~ ("Funds") will serve as the contract between the Grantee and the Sub-grantee for the purpose of the approved Project. This grant amount represents the total Federal share of the total cost of the activities.
  - b.
 

Total estimated cost of the mitigation project is	\$250,000.00
Total Federal share is:	\$187,500.00
Local share:	\$ 62,500.00

Introduced on: March 25, 2014  
Adopted on: March 25, 2014  
Official Resolution#: R20140240



- c. The Sub-grantee agrees to provide the necessary local cost share as required by 44 CFR Part 13.24, and the funding will be available within the specified period of time for completion of the activities. Documentation of the use of the local cost share is required.
- d. Any revision, change or modification to the approved scope of work must be submitted to Grantee and be approved by FEMA prior to implementation. Any revision, change or modification that does not receive prior FEMA approval will violate the conditions of the grant.
- e. Payment of the Federal share of the grant amount will be disbursed per the reimbursement schedule. Unless modified by mutual agreement, reimbursement shall be made according to the following reimbursement schedule. Reimbursements shall be paid at 75% of total project cost attributed to each deliverable.

i. Upon project approval, signing of contract with consultant and procurement documentation (10%):	\$ 18,750.00
ii. Upon completion of Risk Analysis and Vulnerability (10%):	\$18,750.00
iii. Upon completion of preliminary plan including all municipal strategies (15%):	\$28,125.00
iv. Upon submission of Final Draft plan to State OEM (20%)	\$ 37,500.00
v. Upon FEMA approval (20%)	\$37,500.00
vi. Upon adoption by all participants and posting of the Final Approved Request plan on the website and require submission of two (2) hard copies and two (2) digital copies of the plan to the State OEM and distribution of the Plan to local participants (25%):	\$ 46,875.00

- 7. The Sub-grantee shall comply with all applicable state and local ordinances, laws, regulations, building codes and standards applicable to this Project.
- 8. The Sub-grantee understands that the period of performance for this grant is three years; and this timeframe does not in any way extend or affect the expiration date of the plan.
- 9. The Sub-grantee has read, understands, and shall comply with the State of New Jersey Single Audit Policy for Recipients of Federal Grants, State Grants and State Aid, 44 CFR Part 14 - Administration of Grants: Audits of State and Local Governments, and OMB Circular A-133.
- 10. The Sub-grantee shall submit to the Grantee quarterly progress reports (QPR), due the 15<sup>th</sup> day of the month following the end of the quarter on the following schedule:
  - a. For the period January through March      Due April 15
  - b. For the period April through June          Due July 15
  - c. For the period July through September      Due October 15
  - d. For the period October through December    Due January 15
  - e. Failure to provide the required reports will result in suspension of grants funds until the required reports are provided and approved by the Grantee.
  - f. The initial QPR shall include:

Introduced on: March 25, 2014 Copy of the published Request for Proposal for Planning Consulting Services (RFP);  
 Adopted on: March 25, 2014 Listing of where and/or how the RFP was published;  
 Official Resolution#: R20140240

- iii. List of all respondents;
  - iv. Evaluation criteria used in consultant selection;
  - v. Statement indication basis of consultant selection; and
  - vi. Copy of the executed contract with the consultant.
- g. The subsequent QPRs should reflect the status and completion date for the project and any problems or circumstances affecting the completion date, scope of work, project costs, or which could be expected to result in non-compliance with the approved grant conditions.

## 11. PROJECT DESCRIPTION

- a. The Sub-grantee shall update the County's multi-jurisdictional multi-hazard mitigation plan that will satisfy the requirements of 44 CFR Part 201 for the County of Passaic and all of its local jurisdictions.
- b. The Sub-grantee shall submit a draft mitigation plan at least three months prior to the plan expiration date (May 12, 2015) and a final mitigation plan prior to the plan expiration date (August 12, 2015).

## 12. PERIOD OF PERFORMANCE EXTENSION

Should the Sub-grantee require a period of performance extension, a request must be submitted to NJOEM at least 60 days prior to December 17, 2016. This request must include a justification for the extension, including: a summary of all work completed and remaining; a statement demonstrating that all work can be completed within the extension period; a revised budget form (if applicable); copies of contracts between the Sub-grantee and third parties for work to be performed; copies of the contract of sale; and any other material supporting the extension.

## 13. CONDITIONS OF APPROVAL

- a. The Sub-grantee shall use the "Template Scope of Work" (SOW) to be provided by the New Jersey Office of Emergency Management as an attachment to any forthcoming RFP for mitigation planning services. The Template SOW will be consistent with the federal standards found at § 201.6 Local Mitigation Plans, within Part 201 of Title 44: Emergency Management and Assistance and will contain a summary of appropriate data resources and existing evaluation tools available to be leveraged. If the planning services will be completed "in-house," – that is, by the Sub-grantee – the Template SOW will be utilized by the Sub-grantee as the SOW.
- b. The Sub-grantee shall require that the drafters of the mitigation plan, whether third parties or in-house, complete the following activities as per the Local Mitigation Planning Handbook, March 2013, available at [www.fema.gov/library/viewRecord.do?id=7209](http://www.fema.gov/library/viewRecord.do?id=7209):
  - i. Identification and engagement of a wide range of planning participants, including but not limited to the County Planning Board, County Engineer, County Planning Department, County Economic Development organizations, County Open Space Program Coordinators, and any other

relevant parties that fall into the following categories;

1. Community-based engagement, including consultation with municipal planning boards;
  2. Private sector engagement focused on regionally significant employers;
  3. Public sector engagement with relevant government agencies;
- ii. Analysis of and integration with county or municipal master plans (including vulnerability analysis/risk assessments), zoning, subdivision and other land use regulations (if appropriate), capital improvement plans or programs, public infrastructure plans, etc.;
  - iii. Multi-jurisdictional risk analysis that builds on existing and new data prepared for and contained within the State Hazard Mitigation Plan, with suggested regional and local solutions; and
  - iv. Identification of implementation strategies, including analysis of non-governmental funding sources available for project completion.

--- Signatures follow on next page ---

HAZARD MITIGATION GRANT PROGRAM (CFDA#97.039)  
GRANT AGREEMENT

IN WITNESS WHEREOF, the parties hereto have executed this State-Local Grant Agreement on the day and year set forth below:

SUB-GRANTEE - COUNTY OF PASSAIC  
OFFICE OF EMERGENCY MANAGEMENT

\_\_\_\_\_

\_\_\_\_\_ Date

\_\_\_\_\_

\_\_\_\_\_ Date

\_\_\_\_\_

\_\_\_\_\_ Date

GRANTEE

\_\_\_\_\_  
Marc-Philip Ferzan                      Date  
Governor's Authorized Representative  
State of New Jersey

\_\_\_\_\_

# Passaic County Board of Chosen Freeholders

OFFICE OF THE  
PASSAIC COUNTY FREEHOLDERS

Director Pasquale "Pat" Lepore  
Deputy Director Theodore O. Best, Jr.  
John W. Bartlett  
Ronda Casson Cotroneo  
Terry Duffy  
Bruce James  
Hector C. Lora

401 Grand Street  
Paterson, New Jersey 07505

Tel: 973-881-4402  
Fax: 973-742-3746

Anthony J. De Nova III

Administrator

William J. Pascrell, III, Esq.

County Counsel

Louis E. Imhof, III, RMC

Clerk Of The Board



## Public Meeting (Board Meeting)

Date: Mar 25, 2014 - 5:30 PM

Location: County Administration  
220  
401 Grand Street  
Paterson, NJ 07505

Agenda: RESOLUTION AUTHORIZING PURCHASE OF MAINTENANCE AND USAGE FOR ALL COPY MACHINES FOR CALENDAR YEAR 2014 THROUGH STATE CONTRACT FOR THE PASSAIC COUNTY SHERIFF'S OFFICE, ALL AS NOTED IN THE RESOLUTION

THIS RESOLUTION WAS REQUESTED BY:  
SHERIFF'S DEPT

REVIEWED BY:

  
Anthony J. De Nova III  
COUNTY ADMINISTRATOR

APPROVED AS TO FORM AND LEGALITY:

  
William J. Pascrell, III, Esq.  
COUNTY COUNSEL

Law and Public Safety  
COMMITTEE NAME

Official Resolution#	R20140241						
Meeting Date	03/25/2014						
Introduced Date	03/25/2014						
Adopted Date	03/25/2014						
Agenda Item	I-42						
CAF #	4-01-25-157-001-213						
Purchase Req. #	R4-00317						
Result	Adopted						
FREEHOLDER	PRES.	ABS.	MOVE	SEC	AYE	NAY	ABST.
Lepore	✓				✓		
Best Jr	✓		✓		✓		
Bartlett	✓			✓	✓		
Cotroneo	✓				✓		
Duffy	✓				✓		
James	✓				✓		
Lora	✓				✓		

PRES.= present ABS.= absent  
MOVE= moved SEC= seconded  
AYE= yes NAY= no ABST.= abstain

Dated: March 26, 2014

**RESOLUTION AUTHORIZING PURCHASE OF MAINTENANCE  
AND USAGE FOR ALL COPY MACHINES FOR CALENDAR  
YEAR 2014 THROUGH STATE CONTRACT FOR THE PASSAIC  
COUNTY SHERIFF'S OFFICE**

**WHEREAS** The Passaic County Sheriff's Office has requested the purchase of maintenance and usage for all copy machines from De Lage Landen Operational Services, LLC, in the sum of \$81,543.60 for calendar year 2014 through State Contract # 68058; and

**WHEREAS** the Passaic County Board of Chosen Freeholders is desirous of approving said purchase in accordance with the terms of the State Contract and authorizing the Purchasing Agent to issue the appropriate Purchase Order; and

**WHEREAS** the Freeholder Law and Public Safety Committee has considered this matter and recommended this resolution to the full Board for adoption; and

**WHEREAS** a certification is attached indicating that funds are available for the above contemplated expenditure from budgeted funds;

**NOW THEREFORE BE IT RESOLVED** by the Board of Chosen Freeholders of the County of Passaic that it hereby authorizes the purchase of the goods and/or services described above in accordance with the terms of the applicable State Contract; and

**BE IT FURTHER RESOLVED** that the Purchasing Agent and all other necessary officers and employees be and hereby are authorized and directed to take such further actions and sign such documents as are

necessary to effectuate the purpose of this resolution, including but not limited to issuance of an appropriate Purchase Order.

Dated: March 25, 2014

CERTIFICATION OF AVAILABLE FUNDS

THIS IS TO CERTIFY THAT FUNDS ARE AVAILABLE AS FOLLOWS:

AMOUNT: \$81,543.60

APPROPRIATION: 4-01-25-157-001-213

PURPOSE: To authorize the purchase of maintenance and usage for all copy machines from De Lage Landen Operational Services, LLC for Calendar Year 2014 for the Passaic County Sheriff's Office.

  
Michael Katz, County Treasurer

DATED: February 25, 2014



**COUNTY OF PASSAIC**  
 CO OF PASSAIC, (Q) 973-247-3310  
 SHERIFF'S DEPT. ATTN: CAROLINE  
 495 RIVER STREET- 2ND FLOOR  
 PATERSON, NJ 07524

REQUISITION	
<b>Res Pg: 1.42-5</b>	
NO.	R4-00317

S H I P  T O	
V E N D O R	VENDOR #: 09258 DE LAGE LANDEN OPERATIONAL SERVICES, LLC 1111 OLD EAGLE SCHOOL ROAD WAYNE, PA 19087

ORDER DATE: 01/16/14  
 DELIVERY DATE:  
 STATE CONTRACT: 68058  
 F.O.B. TERMS:

QTY/UNIT	DESCRIPTION	ACCOUNT NO.	UNIT PRICE	TOTAL COST
1.00	PARTIAL PAYMENT FIRST 2 MONTHS WILL INCREASE AS NEEDED. OBTAINING RESO FOR REMAINING BALANCE.	4-01-25-157-001-213	13,591.0000	13,591.00
			TOTAL	13,591.00

Introduced on: March 25, 2014  
 Adopted on: March 25, 2014  
 Official Resolution#: R20140241

\_\_\_\_\_  
 REQUESTING DEPARTMENT

\_\_\_\_\_  
 DATE

# Passaic County Board of Chosen Freeholders

OFFICE OF THE  
PASSAIC COUNTY FREEHOLDERS

Director Pasquale "Pat" Lepore  
Deputy Director Theodore O. Best, Jr.  
John W. Bartlett  
Ronda Casson Cotroneo  
Terry Duffy  
Bruce James  
Hector C. Lora

401 Grand Street  
Paterson, New Jersey 07505

Tel: 973-881-4402  
Fax: 973-742-3746

Anthony J. De Nova III

Administrator

William J. Pascrell, III, Esq.

County Counsel

Louis E. Imhof, III, RMC

Clerk Of The Board



## Public Meeting (Board Meeting)

Date: Mar 25, 2014 - 5:30 PM

Location: County Administration  
220  
401 Grand Street  
Paterson, NJ 07505

Agenda: RESOLUTION AUTHORIZING PURCHASE OF AUTOMOBILE PARTS FOR THE PASSAIC COUNTY SHERIFF'S VEHICLE FLEET THROUGH STATE CONTRACT, ALL AS NOTED IN THE RESOLUTION

THIS RESOLUTION WAS REQUESTED BY:  
SHERIFF'S DEPT

REVIEWED BY:

  
Anthony J. De Nova III  
COUNTY ADMINISTRATOR

APPROVED AS TO FORM AND LEGALITY:

  
William J. Pascrell, III, Esq.  
COUNTY COUNSEL

Law and Public Safety  
COMMITTEE NAME

<b>Official Resolution#</b>	<b>R20140242</b>						
Meeting Date	03/25/2014						
Introduced Date	03/25/2014						
Adopted Date	03/25/2014						
Agenda Item	I-43						
CAF #	4-01-25-157-001-249						
Purchase Req. #	R4-02144						
Result	Adopted						
<b>FREEHOLDER</b>	<b>PRES.</b>	<b>ABS.</b>	<b>MOVE</b>	<b>SEC</b>	<b>AYE</b>	<b>NAY</b>	<b>ABST.</b>
Lepore	✓				✓		
Best Jr	✓		✓		✓		
Bartlett	✓			✓	✓		
Cotroneo	✓				✓		
Duffy	✓				✓		
James	✓				✓		
Lora	✓				✓		

PRES.= present ABS.= absent  
MOVE= moved SEC= seconded  
AYE= yes NAY= no ABST.= abstain

Dated: March 26, 2014

**RESOLUTION AUTHORIZING PURCHASE OF AUTOMOBILE PARTS FOR  
THE PASSAIC COUNTY SHERIFF'S VEHICLE FLEET THROUGH STATE  
CONTRACT**

**WHEREAS** the Passaic County Office Sheriff's Office has requested the purchase of parts for the Sheriff's vehicle fleet, from Route 23 Automall, in the amount of \$10,000.00 through State Contract #79167; and

**WHEREAS** the Board of Chosen Freeholders is desirous of approving said purchase in accordance with the terms of the applicable State Contract and authorizing the Purchasing Agent to issue the appropriate Purchase Order; and

**WHEREAS** the Freeholder Law and Public Safety Committee has considered this matter and recommended this resolution to the full Board for adoption; and

**WHEREAS** a certification is attached indicating that funds are available for the within contemplated expenditure;

**NOW THEREFORE BE IT RESOLVED** by the Board of Chosen Freeholders of the County of Passaic that it hereby authorizes the purchase of the above referenced automobile parts for the Sheriff's vehicle fleet in accordance with the terms of the applicable State Contract referenced above; and

**BE IT FURTHER RESOLVED** that the Purchasing Agent and all other necessary officers and employees be and hereby are authorized and directed to take such further actions and sign such documents as are necessary to effectuate the purpose of this resolution, including but not limited to issuance of appropriate Purchase Order.

Dated: March 25, 2014

CERTIFICATION OF AVAILABLE FUNDS

THIS IS TO CERTIFY THAT FUNDS ARE AVAILABLE AS FOLLOWS:

AMOUNT: \$10,000.00

APPROPRIATION: 4-01-25-157-001-249

PURPOSE: To authorize the purchase of automobile parts from Route 23 Automall for the Passaic County Sheriff's vehicle fleet.

  
Michael Katz, County Treasurer

DATED: February 25, 2014

**COUNTY OF PASSAIC**  
 CO OF PASSAIC, (Q)973-247-3310  
 SHERIFF'S DEPT. ATTN: CAROLINE  
 495 RIVER STREET- 2ND FLOOR  
 PATERSON, NJ 07524

REQUISITION	Res Pg: 1.43-4
NO.	R4-02144

S H I P  T O	
V E N D O R	<p style="text-align: right;">VENDOR #: 04422</p> <p>ROUTE 23 AUTOMALL          1301 ROUTE 23 SOUTH          BUTLER, NJ 07405</p>

ORDER DATE: 03/07/14  
 DELIVERY DATE:  
 STATE CONTRACT: 79167  
 F.O.B. TERMS:

QTY/UNIT	DESCRIPTION	ACCOUNT NO.	UNIT PRICE	TOTAL COST
1.00	PARTIAL PAYMENT	4-01-25-157-001-249	10,000.0000	10,000.00
			TOTAL	10,000.00

Introduced on: March 25, 2014  
 Adopted on: March 25, 2014  
 Official Resolution#: R20140242

\_\_\_\_\_  
 REQUESTING DEPARTMENT DATE

# Passaic County Board of Chosen Freeholders

OFFICE OF THE  
PASSAIC COUNTY FREEHOLDERS

Director Pasquale "Pat" Lepore  
Deputy Director Theodore O. Best, Jr.  
John W. Bartlett  
Ronda Casson Cotroneo  
Terry Duffy  
Bruce James  
Hector C. Lora

401 Grand Street  
Paterson, New Jersey 07505

Tel: 973-881-4402  
Fax: 973-742-3746

Anthony J. De Nova III

Administrator

William J. Pascrell, III, Esq.

County Counsel

Louis E. Imhof, III, RMC

Clerk Of The Board



## Public Meeting (Board Meeting)

Date: Mar 25, 2014 - 5:30 PM

Location: County Administration  
220  
401 Grand Street  
Paterson, NJ 07505

Agenda: RESOLUTION AUTHORIZING PURCHASE OF PERSONAL HYGIENE ITEMS FOR THE PASSAIC COUNTY JAIL FROM CHARM TEX , ALL AS NOTED IN THE RESOLUTION

THIS RESOLUTION WAS REQUESTED BY:  
SHERIFF'S DEPT

REVIEWED BY:

  
Anthony J. De Nova III  
COUNTY ADMINISTRATOR

APPROVED AS TO FORM AND LEGALITY:

  
William J. Pascrell, III, Esq.  
COUNTY COUNSEL

Law and Public Safety  
COMMITTEE NAME

<b>Official Resolution#</b>	<b>R20140243</b>						
Meeting Date	03/25/2014						
Introduced Date	03/25/2014						
Adopted Date	03/25/2014						
Agenda Item	I-44						
CAF #	4-01-25-157-005-M01						
Purchase Req. #	R4-01649						
Result	Adopted						
<b>FREEHOLDER</b>	<b>PRES.</b>	<b>ABS.</b>	<b>MOVE</b>	<b>SEC</b>	<b>AYE</b>	<b>NAY</b>	<b>ABST.</b>
Lepore	✓				✓		
Best Jr	✓		✓		✓		
Bartlett	✓			✓	✓		
Cotroneo	✓				✓		
Duffy	✓				✓		
James	✓				✓		
Lora	✓				✓		

PRES.= present ABS.= absent  
MOVE= moved SEC= seconded  
AYE= yes NAY= no ABST.= abstain

Dated: March 26, 2014

**RESOLUTION AUTHORIZING PURCHASE OF PERSONAL HYGIENE  
ITEMS FOR THE PASSAIC COUNTY JAIL FROM CHARM TEX**

**WHEREAS** the Passaic County Office Sheriff's Office has requested the purchase of feminine personal hygiene items for the Passaic County Jail from Charm Tex, in the sum of \$4,342.50; and

**WHEREAS** the Board of Chosen Freeholders is desirous of approving said purchase and authorizing the Purchasing Agent to issue the appropriate Purchase Order; and

**WHEREAS** this purchase is not subject to the requirements of N.J.S.A. 19:44A-20.4(a) at this time since the amount of money involved in this purchase is less than the monetary value required under the new "Pay to Play" statute; and

**WHEREAS** the Freeholder Law and Public Safety Committee has considered this matter and recommended this resolution to the full Board for adoption; and

**WHEREAS** a certification is attached indicating that funds are available for the within contemplated expenditure;

**NOW THEREFORE BE IT RESOLVED** by the Board of Chosen Freeholders of the County of Passaic that it hereby authorizes the purchase of the above referenced items; and

**BE IT FURTHER RESOLVED** that the Purchasing Agent and all other necessary officers and employees be and hereby are authorized and directed to take such further actions and sign such documents as are necessary to effectuate the purpose of this resolution, including but not limited to issuance of appropriate Purchase Order.

Dated: March 25, 2014

CERTIFICATION OF AVAILABLE FUNDS

THIS IS TO CERTIFY THAT FUNDS ARE AVAILABLE AS FOLLOWS:

AMOUNT: \$4,342.50

APPROPRIATION: 4-01-25-157-005-M01

PURPOSE: To authorize the purchase of personal hygiene items for the Passaic County Jail from Charm Tex.

  
Michael Katz, County Treasurer

DATED: February 25, 2014



**COUNTY OF PASSAIC**  
 CO OF PASSAIC, (Q)973-247-3310  
 SHERIFF'S DEPT. ATTN: CAROLINE  
 495 RIVER STREET- 2ND FLOOR  
 PATERSON, NJ 07524

REQUISITION	
NO.	R4-01649

S H I P T O	COUNTY OF PASSAIC JAIL -OFFICER AVELLA 11 MARSHALL STREET PATERSON, NJ 07505
V E N D O R	VENDOR #: 06263
	CHARM TEX 1618 CONEY ISLAND AVENUE BROOKLYN, NY 11230

ORDER DATE: 02/20/14  
 DELIVERY DATE:  
 STATE CONTRACT:  
 F.O.B. TERMS:

QTY/UNIT	DESCRIPTION	ACCOUNT NO.	UNIT PRICE	TOTAL COST
1.00/CS	QUOTE 0072205 2-4-14 SANITARY NAPKINS BULK WINGED 864/CS	4-01-25-157-005-M01	4,342.5000	4,342.50
			TOTAL	4,342.50

Introduced on: March 25, 2014  
 Adopted on: March 25, 2014  
 Official Resolution#: R20140243

\_\_\_\_\_  
 REQUESTING DEPARTMENT DATE

# Passaic County Board of Chosen Freeholders

OFFICE OF THE  
PASSAIC COUNTY FREEHOLDERS

Director Pasquale "Pat" Lepore  
Deputy Director Theodore O. Best, Jr.  
John W. Bartlett  
Ronda Casson Cotroneo  
Terry Duffy  
Bruce James  
Hector C. Lora

401 Grand Street  
Paterson, New Jersey 07505  
Tel: 973-881-4402  
Fax: 973-742-3746

Anthony J. De Nova III  
*Administrator*  
William J. Pascrell, III, Esq.  
*County Counsel*  
Louis E. Imhof, III, RMC  
*Clerk Of The Board*



## Public Meeting (Board Meeting)

Date: Mar 25, 2014 - 5:30 PM

Location: County Administration  
220  
401 Grand Street  
Paterson, NJ 07505

Agenda: RESOLUTION AUTHORIZING A CONTRACT WITH RENOVO SOFTWARE OF EDINA, MN, TO PROVIDE COMPUTER SOFTWARE FOR THE OPERATION OF THE INMATE VIDEO VISITATION SYSTEM AT THE PASSAIC COUNTY JAIL, ALL AS NOTED IN THE RESOLUTION

THIS RESOLUTION WAS REQUESTED BY:  
SHERIFF'S DEPT

REVIEWED BY:

Anthony J. De Nova III  
COUNTY ADMINISTRATOR

APPROVED AS TO FORM AND LEGALITY:

William J. Pascrell, III, Esq.  
COUNTY COUNSEL

Law and Public Safety

COMMITTEE NAME

Official Resolution#	R20140244						
Meeting Date	03/25/2014						
Introduced Date	03/25/2014						
Adopted Date	03/25/2014						
Agenda Item	I-45						
CAF #							
Purchase Req. #							
Result	Adopted						
FREEHOLDER	PRES.	ABS.	MOVE	SEC	AYE	NAY	ABST.
Lepore	✓				✓		
Best Jr	✓		✓		✓		
Bartlett	✓			✓	✓		
Cotroneo	✓				✓		
Duffy	✓				✓		
James	✓				✓		
Lora	✓				✓		

PRES.= present ABS.= absent  
MOVE= moved SEC= seconded  
AYE= yes NAY= no ABST.= abstain

Dated: March 26, 2014

**RESOLUTION AUTHORIZING A CONTRACT WITH RENOVO SOFTWARE OF EDINA, MN, TO PROVIDE COMPUTER SOFTWARE FOR THE OPERATION OF THE INMATE VIDEO VISITATION SYSTEM AT THE PASSAIC COUNTY JAIL**

**WHEREAS** as a result of a proposal in May of 2012

Simple/Grinnel LP of Rockaway, New Jersey, was awarded a contract to put together and construct an Inmate Video Visitation System (System) for the Pasic County Jail; and

**WHEREAS** that proposal suggested that the said System would be designed to utilize computer software provided by Renovo Software of Edina, MN, with the understanding when the System was ready to be operated the Jail and Renovo would enter into an agreement for use of the software based upon a revenue sharing arrangement; and

**WHEREAS** the Passaic County Sheriff's Department is now reporting that the System can be operated, and that said Renovo Software is offering to install its software for the Jail's use for three (3) years, with two (2) one (1) year options to renew, in return for 55% of gross revenues received from the said System's use; and

**WHEREAS** the Passaic County Sheriff's Department is recommending that the Board of Chosen Freeholders of Passaic County approve an agreement by and between Renovo Software and the Department for use of this software; and

**WHEREAS** the proposed award of this agreement would be an exception under the New Jersey Local Public Contract Law inasmuch as the software being provided for this Inmate Video

Visitation System is both specialized and proprietary (N.J.S.A. 40A:11-5(d); and

**WHEREAS** it is anticipated that the revenue received for this System may be over the monetary threshold set forth under the Pay to Paly Law (N.J.S.A. 19:44A-20.3); and

**WHEREAS** the said Board, by Resolution 06-97 dated February 14, 2006 established a policy of only awarding contracts in excess of the monetary threshold set forth under the Pay to Play Law only under a fair and open process; and

**WHEREAS** the Passaic County Sheriff's Department is requesting that the said Board make an exception in this case because of the need for this specialized and proprietary computer software; and

**WHEREAS** the Freeholder Committee for Law and Public Safety at its March 18, 2014 meeting received this matter and is recommending that it be approved by the full Board;

**NOW THEREFORE BE IT RESOLVED** by the Board of Chosen Freeholders of Passaic County that it hereby authorizes a non-fair and non-open contract by and between the Passaic County Sheriff's Department and Renovo Software of Edina, MN for use of its software in operating the recently installed Inmate Video Visitation System at the Passaic County Jail for a three (3) year period with two (2) one (1) year options to renew predicated upon a 55%-45% split of gross revenues received from the System's use; and

**BE IT FURTHER RESOLVED** that this contract is being awarded as an exception to the policy of the Board as set forth in its resolution R-06-97 dated February 14, 2006 because of the special circumstances of this situation and the policy of the Board as set forth in that resolution shall remain in full force and effect;

**BE IT FURTHER RESOLVED** that in this case the Passaic County Sheriff or his designee be authorized to execute the necessary contract on behalf of the Department.

Dated: March 25, 2014

## Renovo Software Internet Visitation and VisPay Solution

3/14/13

To Whom It May Concern,

This letter is to confirm that VisAnywhere and VisPay software, designated to expand functionality for Passaic County Jail's Video Visitation System, is a sole source product, manufactured, sold and distributed exclusively by Renovo Software Inc. Renovo Software is the publisher of the application software and revenue generation software. No other company can provide the functionality to interface with Passaic County's current video visitation system. This product must be acquired directly by institutions from Passaic County. There are other no agents or dealers authorized to represent this product.

There are no other products available to purchase that would serve Passaic County Jail's purpose for acquiring the functionality to conduct internet video visits. Renovo has specifically designed VisAnywhere and VisPay for the corrections industry and has specially trained staff to provide support on the System's Server, Software Application and Codec's.

If you desire additional information, don't hesitate to contact me at (952) 229 - 8462 at any time or visit our website at [www.renovosoftware.com](http://www.renovosoftware.com) Thank you for your interest in our products.

Sincerely,

*Nathan Peterson*  
Customer Account Manager  
[Npeterson@renovosoftware.com](mailto:Npeterson@renovosoftware.com)  
952-229-8462



## VisPay Agreement

This VisPay Agreement (hereinafter, the "Agreement") is effective this 7<sup>th</sup> day of March, 2014, by and between Renovo Software, Inc. located at 5666 Lincoln Drive, Suite 206, Edina, MN 55436 (hereinafter "RENOVO") and Passaic County Jail located at 11 Marshall Street, Paterson, NJ 07501 (hereinafter "Customer") (collectively, the "Parties"). The Parties agree that this Agreement shall govern the mutual rights and obligations of the parties with respect to RENOVO's VisPay Module

I. PREFACE. RENOVO has developed and owns the VisPay module for the corrections industry ("VisPay"). VisPay provides a method for payment of visitation fees and inmate messaging fees. Customer desires that RENOVO install, and maintain VisPay for Customer. RENOVO and Customer desire that VisPay be the sole and exclusive method for payment of revenue generation associated with inmate visits (internet video visits and extra onsite visits) and/or inmate messaging ("VisMail") at Customer's facilities (the "Facilities"). The services for which VisPay shall be provided are as designated on Exhibit A hereto. In consideration for agreeing to allow VisPay to be the exclusive payment method for all revenue generating visits and/or inmate messaging for use by inmates at the Facilities, RENOVO agrees to pay Customer the fees set forth in Section III below.

### II. VisPay INSTALLATION AND OPERATION.

A. Within a reasonable period of time after execution of this Agreement, RENOVO shall install VisPay so that it is operable at Customer's Facilities.

B. CUSTOMER shall be solely responsible for all charges related to providing internet access and the necessary bandwidth from the Facilities to the World Wide Web and RENOVO shall not be liable for any damages incurred by Customer as a result of Customer's failure to provide adequate internet access and the necessary bandwidth from the Facilities to the World Wide Web.

### III. COMPENSATION

A. In consideration for granting RENOVO the exclusive right to derive revenue from all revenue generating visits and/or revenue generating inmate messaging (VisMail) at the Facilities, RENOVO will pay Customer Fifty (55%) percent of the "gross payments collected" through VisPay for revenue generating visits and revenue generating inmate messaging at the Facilities. "Gross Payments Collected," as used herein, means RENOVO's total revenue from all billed visits less a 5% transaction fee. Notwithstanding anything to

the contrary herein, taxes, fees and other charges collected on behalf of Local, State, Federal or other governmental agencies are not considered to be revenue for the purpose of this definition. Payments to Customer shall be due monthly for the preceding month within forty-five (45) days following the collection of records from the preceding month. All payments to Customer shall be final and binding upon Customer unless written objection thereto is received by RENOVO within sixty (60) days of RENOVO's mailing of the payment to Customer.

B. Exhibit A to this Agreement sets forth the VisPay services to be provided by RENOVO.

C. In the event of a change, repeal, enactment or amendment of any statute or regulation by any governmental authority that increases RENOVO's costs to perform under this Agreement or reduces RENOVO's allowable rates that may be charged to VisPay users, RENOVO shall be entitled to adjust the rates and terms of payment as set forth in Article III (A) above, to recover the increase in operating costs or to compensate for losses in revenues due to decreases in the rates chargeable to VisPay users, said adjustment to take effect no earlier than fifteen (15) days after receipt by Customer of written notice of said adjustment. Any rate increase for reasons other than those stated herein shall be subject to Customer's written approval.

IV. TERM. This Agreement is effective as of the date set forth above, and shall remain in force and effect for **Three (3)** years from the date of installation of RENOVO's VisPay (the "Initial Term") unless the Agreement is earlier terminated in accordance with the termination provisions herein. The CUSTOMER will have **two, 1 year** extension options at the end of the initial term.

### V. TERMINATION

A. In the event a party believes the other is in material breach of this Agreement, that party shall give the breaching party written notice specifying the nature of the breach and an intention to terminate the Agreement if the breach is not cured in accordance with this provision. This written notice shall include, but is not limited to, a statement of the

facts relating to the breach and the action required to cure the breach. The breaching party shall have thirty (30) business days from the receipt of such notice to cure the breach unless the breach is incapable of being cured within the thirty (30) business day period, in which case the Agreement may not be terminated if efforts to cure the breach are initiated within the thirty (30) business day period and diligently pursued to completion. Notwithstanding anything to the contrary herein, if the breach is not cured within ninety (90) days after the receipt of written notice of the breach, the non-breaching party may terminate the Agreement effective immediately upon notice of termination to the breaching party, and may pursue any available legal or equitable remedies for the breach.

B. For the purposes of this Article IV, the term "cause" shall not include nonperformance due to Force Majeure Conditions, or any other causes beyond the non-performing party's control. Force Majeure Conditions include but are not limited to the following: Acts of God, acts of civil or military authority, government regulations, embargoes, epidemics, war, terrorist acts, riots, insurrections, fires, explosions, earthquakes, nuclear accidents, floods, strikes, power blackouts, volcanic action, other major environmental disturbances, unusually severe weather conditions, acts or omissions of third parties, including suppliers and common carriers (collectively referred to as "Force Majeure Conditions").

## VI. LIABILITY

A. NOTWITHSTANDING ANYTHING TO THE CONTRARY IN THIS AGREEMENT, RENOVO SHALL NOT BE LIABLE FOR ANY LOSS OR DAMAGE ARISING DIRECTLY OR INDIRECTLY FROM THE USE OF OR INABILITY TO USE RENOVO'S VISPAY, VISANYWHERE OR VISMAL. RENOVO SHALL NOT BE RESPONSIBLE FOR ANY INDIRECT, CONSEQUENTIAL, SPECIAL, INCIDENTAL OR PUNITIVE DAMAGES, OR FOR LOSS OF PROFITS OR REVENUE, WHETHER OR NOT ADVISED OF THE POSSIBILITY OF SUCH DAMAGES.

B. Customer agrees to indemnify and hold RENOVO, its officers, directors, employees, agents, and subcontractors harmless from any and all claims, losses or liability of any nature whatsoever, including claims interposed by way of defense or counterclaim (and including attorney's fees) arising out of or related to (1) any negligent or intentional acts or omissions by Customer, its officials, agents or employees; (2) any claims arising out of any mis-use of VisPay, VisAnywhere or VisMail software; and (3) any breach of this Agreement by Customer.

## VII. MISCELLANEOUS

A. Authority. Each party to this Agreement warrants and represents that it has the unrestricted right and requisite authority to execute, deliver and perform under this Agreement and to authorize the installation and operation of the VisPay and related equipment in the Facilities. Each party further warrants and represents that the execution of this Agreement has been duly authorized and that the signatory below has the legal authority to enter a binding contract on behalf of the party, and that all actions, resolutions and/or express authorizations required to be obtained prior to entering this Agreement have been taken, passed and/or obtained.

B. Governing Law. The terms of this Agreement shall be interpreted, construed and enforced pursuant to the laws of the State of New Jersey, and the Parties irrevocably consent to the jurisdiction of the federal and state courts presiding in New Jersey.

C. Successors. This Agreement shall be binding upon and inure to the benefit of the Parties hereto and their respective heirs, executors, administrators, legal representatives, successors, and assigns when permitted by this Agreement.

D. Severability. In case any one or more of the provisions contained in this Agreement shall for any reason be held to be invalid, illegal, or unenforceable in any respect, such invalidity, illegality, or unenforceability shall not affect any other provisions thereof and this Agreement shall be construed as if such invalid, illegal, or unenforceable provision had never been contained herein.

E. Entire Agreement. This Agreement, including **EXHIBIT A** contains the entire agreement by and between the Parties and replaces any prior or existing agreements, oral or written, between the Parties concerning the subject matter herein.

F. Modifications. This Agreement cannot be varied, modified or amended orally and can only be varied, modified or amended by a written instrument signed by a representative of each party who has legal authority to enter such Agreement.

G. Assignments. RENOVO reserves the right to assign its rights and obligations under this Agreement without the prior consent of Customer. Any sale or transfer of the business, property or operations of the Facilities shall include an assumption by the buyer of all the terms and conditions of this Agreement. Customer may assign this Agreement only with the written consent of RENOVO, which consent shall not be unreasonably withheld.



H. No Waiver. No waiver by either party of any event of default under this Agreement shall operate as a waiver of any subsequent default.

Warden Tolerico  
11 Marshal Street  
Paterson, NJ 07501

I. Dispute Resolution. Any claim or controversy arising out of or relating to the Agreement shall, upon a party's written request, initially be submitted to a senior manager from each party, who will meet in person and confer in good faith to resolve the dispute within fifteen (15) business days following such notice. In the event the Parties cannot resolve the dispute, the Parties may pursue any available legal or equitable remedy consistent with this Agreement.

K. No Joint Venture. Neither this Agreement nor the disclosure or receipt of Proprietary Information constitutes or implies any promise or intention to enter into a partnership, agency, employment, or joint venture relationship, or to make any investment in any entity, to purchase any products or services by any entity, or to offer any additional information, products, or services to any entity. The relationship hereby established between the Parties is that of independent contractors.

J. Notices. All notices required to be in writing herein shall be delivered by each party to the other party by certified mail at the addresses for each party set forth below. Either party may change the designated address and/or recipient upon written notice to the other party in accordance with this provision.

L. Interpretation. Section headings in this Agreement are for reference only and shall not be construed as modifying any provisions herein.

If to RENOVO:

Renovo Software Inc.  
Attn: Controller  
5666 Lincoln Drive, Suite #206  
Edina, MN 55436

M. Counterparts. This Agreement may be executed in any number of counterparts, each of which shall be an original, and all of which shall together constitute one agreement.

If to Customer:

Passaic County Jail  
Attn:

N. Customer must, and hereby agrees to stay current on annual upgrades and support contracts in order for VisPay to be properly supported and functional.

**IN WITNESS WHEREOF**, the Parties have executed this Agreement the date first above written.

CUSTOMER

RENOVO SOFTWARE, INC.

By: \_\_\_\_\_

By: \_\_\_\_\_

Name:  
Title:

Name:  
Title:

Witness:

Witness:

By: \_\_\_\_\_  
Name:

By: \_\_\_\_\_  
Name:

# Passaic County Board of Chosen Freeholders

OFFICE OF THE  
PASSAIC COUNTY FREEHOLDERS

Director Pasquale "Pat" Lepore  
Deputy Director Theodore O. Best, Jr.  
John W. Bartlett  
Ronda Casson Cotroneo  
Terry Duffy  
Bruce James  
Hector C. Lora

401 Grand Street  
Paterson, New Jersey 07505

Tel: 973-881-4402  
Fax: 973-742-3746

Anthony J. De Nova III

Administrator

William J. Pascrell, III, Esq.

County Counsel

Louis E. Imhof, III, RMC

Clerk Of The Board



## Public Meeting (Board Meeting)

Date: Mar 25, 2014 - 5:30 PM

Location: County Administration  
220  
401 Grand Street  
Paterson, NJ 07505

Agenda: RESOLUTION AUTHORIZING AN APPLICATION TO THE NORTH JERSEY TRANSPORTATION PLANNING AUTHORITY (NJPTA), FOR FY-2014, FOR TRANSPORTATION CLEAN AIR MEASURES (TCAM) PROGRAM, IN THE AMOUNT OF \$585,000.00, WITH A 20% LOCAL MATCHING FUNDS, TO CONSTRUCT BICYCLE AND PEDESTRIAN FACILITIES ASSOCIATED WITH MORRIS CANAL GREENWAY PROJECT IN THE CITIES OF PATERSON AND CLIFTON, ALL AS NOTED IN THE RESOLUTION

THIS RESOLUTION WAS REQUESTED BY:

REVIEWED BY:

Anthony J. De Nova III  
COUNTY ADMINISTRATOR

APPROVED AS TO FORM AND LEGALITY:

William J. Pascrell, III, Esq.  
COUNTY COUNSEL

Planning and Economic Development

COMMITTEE NAME

Official Resolution#	R20140245						
Meeting Date	03/25/2014						
Introduced Date	03/25/2014						
Adopted Date	03/25/2014						
Agenda Item	I-46						
CAF #							
Purchase Req. #							
Result	Adopted						
FREEHOLDER	PRES.	ABS.	MOVE	SEC	AYE	NAY	ABST.
Lepore	✓				✓		
Best Jr	✓		✓		✓		
Bartlett	✓			✓	✓		
Cotroneo	✓				✓		
Duffy	✓				✓		
James	✓				✓		
Lora	✓				✓		

PRES.= present ABS.= absent  
MOVE= moved SEC= seconded  
AYE= yes NAY= no ABST.= abstain

Dated: March 26, 2014

**RESOLUTION AUTHORIZING AN APPLICATION TO THE NORTH JERSEY TRANSPORTATION PLANNING AUTHORITY (NJPTA), FOR FY-2014, FOR TRANSPORTATION CLEAN AIR MEASURES (TCAM) PROGRAM, IN THE AMOUNT OF \$585,000.00, WITH A 20% LOCAL MATCHING FUNDS, TO CONSTRUCT BICYCLE AND PEDESTRIAN FACILITIES ASSOCIATED WITH MORRIS CANAL GREENWAY PROJECT IN THE CITIES OF PATERSON AND CLIFTON**

**WHEREAS** on February 26, 2014, the Passaic County Planning Department received notice from the North Jersey Transportation Authority encouraging it to apply for the Transportation Clean Air Measures Program funds supported by Local Congestion Mitigation Air Quality Funds for the County's Morris Canal Greenway Project; and

**WHEREAS**, the Morris Canal Greenway Project has previously been identified in the NJTPA Strategy Evaluation process as one of the hallmark projects identified in the Transportation Element of the Passaic County Master Plan, which was funded through the NJTPA Subregional Studies Program; and

**WHEREAS**, this route was identified through the Morris Canal Greenway Feasibility Study funded through an NJAC grant and subsequently adopted as an element of the Passaic County Master Plan in June of 2011; and

**WHEREAS**, approximately six mile portion of the Morris Canal Greenway that passes through the Cities of Clifton and Paterson; and

**WHEREAS**, the engineering of the project will utilize the Passaic County Complete Streets Guidelines outlined as a goal in the NJTPA Regional Transportation Plan (Plan 2040);and

**WHEREAS** the project has already received \$532,566.40 in

Transportation Community and System Preservation Program as well as \$133,141.60 in matching funds from the Passaic County Open Space and Farmland Preservation Trust Fund:

**WHEREAS**, the County Planning Department's proposal, FY-2014 TCAM INITIATIVES, indicates that grant funds will be sought for Passaic County Project entitled: Transportation Clean Air Measures (TCAM) Program, as follows:

Federal Highway Administration Program (FHAP) (TCSP):	\$532,566.40
County Match from the Open Space and Farmland Preservation Trust Fund:	\$133,141.60
<b>Total</b>	<b>\$665,708.00.</b>

(See attached); and

**WHEREAS**, there is a required County match in the amount of \$133,141,60, from the County Open Space and Farmland Preservation Trust Fund, if and when the grant is received; and

**WHEREAS**, this matter was approved by the Freeholder Planning and Economic Development Committee by pull recommended to the full Board for approval;

**NOW THEREFORE BE IT RESOLVED** by the Board of Chosen Freeholders of the County of Passaic that it hereby authorizes an application for \$532,566.40.00 in grant funds, with a county match of \$133,141.60, to the NJTPA/TCSP, for the project entitled: Transportation Clean Air Measures (TCAM) Program as set forth above; and

**BE IT FURTHER RESOLVED** that the Freeholder Director and Clerk to the Board are hereby authorized to execute the necessary documents and agreements on behalf of the County of Passaic.

Dated: March 25, 2014

Introduced on: March 25, 2014  
Adopted on: March 25, 2014  
Official Resolution#: R20140245

## COUNTY OF PASSAIC RESOLUTION REQUEST FORM

1. NAME OF REQUESTER & Tel #: Michael Lysicatos 973.569.4047 \_\_\_\_\_

2. DESCRIPTION OF RESOLUTION (PLEASE BE AS SPECIFIC AS POSSIBLE)

Application to the North Jersey Transportation Planning Authority's 2014 Transportation Clean Air Measures (TCAM) Program for \$585,000.00, with a 20% local match from the Open Space Trust Fund, to construct bicycle and pedestrian facilities associated with the Morris Canal Greenway project in the Cities of Paterson and Clifton.

3. CERTIFICATION INFORMATION:

AMOUNT OF EXPENDITURE: \_\_\_\_\_

BUDGET ACCOUNT #: \_\_\_\_\_

ATTACH A COPY OF A "DETAIL BUDGET ACCOUNT STATUS INCLUDING REQUISITION ITEMS" PAGE FROM EDMONDS

PLEASE NOTE THAT RESOLUTIONS FOR ALL CONTRACT AWARDS AND OTHER EXPENDITURES REQUIRE A CERTIFICATION OF FUNDS IN ORDER TO BE PLACED ON THE AGENDA. IT IS THE RESPONSIBILITY OF THE REQUESTING DEPARTMENT TO IDENTIFY THE APPLICABLE BUDGET LINE TO THE FINANCE DEPARTMENT. FAILURE TO DO SO WILL RESULT IN DELAYS IN PROCESSING THE RESOLUTION REQUEST.

4. COMMITTEE REVIEW:

DATE

\_\_\_ Administration & Finance

\_\_\_\_\_

\_\_\_ Public Works / Buildings & Grounds

\_\_\_\_\_

X Planning & Economic Development

March 18, 2014

\_\_\_ Health, Human Services & Community Affairs

\_\_\_\_\_

\_\_\_ Law & Public Safety

\_\_\_\_\_

\_\_\_ Energy & Sustainability

\_\_\_\_\_

\_\_\_ Other(s) Specify: \_\_\_\_\_

\_\_\_\_\_

4. DISTRIBUTION LIST:

X Administration

X Finance

X Counsel

\_\_\_ Clerk to Board

\_\_\_ Other(s) Specify: \_\_\_\_\_

Introduced on: March 25, 2014  
Adopted on: March 25, 2014  
Official Resolution#: R20140245

*Defining the Vision. Shaping the Future.*



One Newark Center, 17th floor, Newark, NJ 07102  
(973) 639-8400 • fax (973) 639-1953 • [www.njtpa.org](http://www.njtpa.org)

*Matthew Holt, Chairman  
Mary K. Murphy, Executive Director*

February 26, 2014

Mr. M. Lysicatos  
Supervising Planner  
Passaic County Planning Board  
930 Riverview Drive, Suite 250  
Totowa, NJ 07512

Dear Mr. Lysicatos,

The NJTPA has received the Passaic County's thumbnail sketch, Morris Canal Greenway (Clifton & Paterson), in application for its Transportation Clean Air Measures (TCAM) program supported by local Congestion Mitigation Air Quality (CMAQ) funds. The NJTPA has completed its review of all thumbnails.

The NJTPA is very supportive of Passaic County's exciting proposal and invites you to complete a full proposal for application to the program. The solicitation package is included. Full proposals are **due at 5:00 p.m. Thursday March 20, 2014**. Proposals should be submitted to my attention and can be electronic or hard copy.

Thank you very much for submitting such an innovative proposal. The NJTPA looks forward to seeing the full proposal as this effort advances. Please do not hesitate to contact me if you have any questions or concerns.

Sincerely,

Liz DeRuchie  
Principal Planner  
NJTPA  
[liz@nitpa.org](mailto:liz@nitpa.org)  
973-639-8446

Copy: Zenobia Fields  
Brian Fineman

**FY 2014 TCAM INITIATIVES**  
**County of Passaic – Thumbnail Sketch**

**Project Sponsor(s):** County of Passaic, Cities of Clifton and Paterson, FHWA  
**Project Name:** Morris Canal Greenway (Cities of Clifton / Paterson)  
**Project Rank:** N/A  
**Estimated \$ Requested:** \$585,000.00 (20% Local Match Included)

**Identify Project:** The approximately six mile portion of the Morris Canal Greenway that passes through the Cities of Clifton and Paterson. This route was identified through the Morris Canal Greenway Feasibility Study funded through an NJAC grant and subsequently adopted as an element of the Passaic County Master Plan in June of 2011. The Morris Canal Greenway project has previously been identified in the NJTPA Strategy Evaluation process and is one of the hallmark projects identified in the Transportation Element of the Passaic County Master Plan which was funded through the NJTPA Subregional Studies Program. The engineering of the project will utilize the Passaic County Complete Streets Guidelines outlined as a goal in the NJTPA Regional Transportation Plan (Plan 2040). The project has already received \$532,566.40 in funding through the Federal Highway Administration's Transportation Community and System Preservation Program as well as \$133,141.60 in matching funds from the Passaic County Open Space and Farmland Preservation Trust Fund.

**Description:** The County of Passaic proposes implementing bicycle and pedestrian improvements along the Morris Canal Greenway in the cities of Paterson and Clifton. Such improvements will draw public attention to the Greenway and ensure the safety of pedestrians, bicyclists, and other recreational users. Improvements include striping of bike lanes and sharrows/share-the-road markings; installing regulatory and wayfinding signs, which will all bear the Morris Canal Greenway logo; and upgrading curbs, sidewalks, and handicap ramps where necessary, for the purpose of ADA compliance. The attached map outlines the extents of the project.

**CMAQ Link:** The project provides continuous connection to approximately 114 bus stops along 18 NJ Transit bus routes, including the Allwood Road park-and-ride, within the most urbanized communities of the County. The construction of continuous bicycle facilities & pedestrian



access will allow for more non-motorized transportation and ultimately improve air quality. The project also falls within a CO Maintenance, 8-Hour Ozone and a PM2.5 Nonattainment area

- Estimated Results:** It is anticipated that the proposed improvements will significantly increase non-motorized travel and mass transit ridership along the greenway alignment in peak hours and during weekends, providing safe access to regional bus services in the surrounding communities. Coordinating improvements with the Passaic County Complete Streets Guidelines will also promote traffic calming along busy County roadways, thus reducing speeds and vehicle emissions. Secondary benefits include increased access to recreational activity through biking and walking and access to facilities along the proposed greenway, such as the Clifton Morris Canal Park and the Great Falls National Historical Park.
- Schedule:** 0 – 6 Months: Finalize design and receive federal authorization  
6 – 12 Months: Complete all final construction bid documents and select a firm to construct the project  
12 – 18 Months: Construction
- Who:** The engineering design work is already underway and is being completed by a subcontractor as part of the FHWA TCSP grant. The final approvals will be granted by the County in coordination with the City of Clifton, City of Paterson and the NJDOT Local Aid office. The County will undertake all preparation of bid documents and construction management.
- Where:** The attached map depicts the extents of the project, connecting bus lines and surrounding neighborhoods.
- Partners:** The County of Passaic is already partnering with the City of Clifton, City of Passaic, Federal Highway Administration, Meadowlink TMA, NJ Bike and Walk Coalition. The project partners also include the myriad of partners who were identified through and contributed to the Morris Canal Feasibility Study.
- Products:** The final product will be 6.18 miles of pedestrian and bicycle improvements that will result in a continuous sidewalk and bicycle facilities accessing regional bus service and connecting numerous communities, recreational opportunities, employment opportunities in the most urbanized portion of Passaic County.

**Contact Person:**

Michael Lysicatos  
Phone - 973.569.4047/Fax - 973.812.3450  
[mlysicatos@passaiccountynj.org](mailto:mlysicatos@passaiccountynj.org)

RIFLE

RIFLE CAMP PARK

46

Montclair State University

VALLEY RD (CR 621)

GROVE ST (CR 623)

ST (CR 509)

Introduced on: March 25, 2014  
Adopted on: March 25, 2014  
Official Resolution#: R20140245

CERTIFICATION OF AVAILABLE FUNDS

THIS IS TO CERTIFY THAT FUNDS ARE AVAILABLE AS FOLLOWS:

AMOUNT: \$25,261.92

APPROPRIATION: C-04-55-820-000-901

PURPOSE: To authorize the purchase of Replacement Furniture from JFD Office Interiors for use at the Preakness Valley Golf Course Club House.

  
Michael Katz, County Treasurer

DATED: February 25, 2014



# County of Passaic

Administration Building  
401 Grand Street • Paterson, New Jersey 07505

OFFICE OF THE COUNTY ENGINEER  
ROOM 524

Steven J. Edmond, P.E.  
County Engineer

TEL: (973) 881-4456  
FAX: (973) 742-3936  
TDD: (973) 279-9786

March 21, 2014

Board of Chosen Freeholders  
Passaic County Administration Building  
401 Grand Street  
Paterson, New Jersey 07505

PROJECT: Replacement Furniture  
Preakness Valley Golf Course Clubhouse  
Wayne, NJ  
State Contract #A81642 JFD Office Interiors  
**G-2004 FURNITURE: OFFICE, LOUNGE**

Dear Members of the Board:

The County of Passaic is desirous to renovate the Preakness Valley Golf Course Clubhouse. Part of the renovation includes replacing existing outdated furniture with new furniture including workstations. Under State Contract G-2004, the County has received a proposal from JFD Office Interiors, New York to provide these services in the amount of \$25,261.92.

This matter was discussed at the Public Works Committee meeting of March 24, 2014 and an award of contract to JFD Office Interiors of Long Island City, New York is recommended to the full Board.

Based upon the above, this Office recommends that the Board of Chosen Freeholders adopt a Resolution awarding the quote for new furniture including workstations for the County Golf Course Club House in the amount of \$25,261.92 to JFD Office Interiors and authorize County Counsel and the Director of Purchasing to prepare and execute the necessary Agreements subject to the availability of funds.

Very truly yours,

Steven J. Edmond, P.E.  
County Engineer

/AET

cc: Chair, Public Works and Buildings & Grounds Committee  
County Administrator  
County Counsel  
Director of Finance

Introduced on: \passaic.local\departments\Engineering\Users\andrew\_t\My Documents\BCF\_Award\_2014\_03\_21.docx  
Adopted on: March 25, 2014  
Official Resolution#: R20140246



11-12 44th Drive  
 Long Island City, NY 11101  
 P.718.729.5222 F.718.729.7477

DATE	PROPOSAL#
03/04/14	9729B

PROJECT#: 030-000010

CUSTOMER:

PASSAIC COUNTY  
 401 GRAND STREET RM# 524  
 PATTERSON NJ 07505  
 PH# 973 881 4424973 742

INSTALL AT:

PASSAIC COUNTY  
 401 GRAND STREET  
 PATTERSON NJ 07505

FAX NUMBER#                      CUSTOMER P.O.#                      SALESPERSON                      TERMS                      SHIP VIA

E. VELASQUEZ-FURN NET 30

#	QTY	PRODUCT	DESCRIPTION	SELL EACH	SELL EXTEND
			PLEASE ADDRESS PO AS FOLLOWS:		
		*	TRENDWAY		
		*	C/O JFD SALES		
		*	P.O.C. BOX 9016		
		*	13467 QUINCY STREET		
		*	HOLLAND MI 49422		
		*	T-NUMER G2004		
		*	NJ STATE CONTRACT # A81642		
1	2	CBFLAT36	CAPTURE BENCH HGT, 12 LAT, 20"D X 36"W	776.52	1,553.04
		.MM	MOD2 APPLIED PULL		
		.1	GR1L HIGHEST GRADE THERMOFUSED LAMINATE		
		.1B	UNIT GR1L WOOD GRAIN THERMOFUSED LAMINATES		
		.XZE	BRAZILWOOD (EXTND LD TIME)		
		.1B	TOP GR1L WOOD GRAIN THERMOFUSED LAMINATES		
		.XZE	BRAZILWOOD (EXTND LD TIME)		
		.1B	GR1L WOODGRAIN VINYL EDGE COLORS		
		.XZE	BRAZILWOOD (EXTND LD TIME)		
		.1B	DRAWER GRD1 WOOD GRAIN THERMOFUSED LAMINATES		
		.XZE	BRAZILWOOD (EXTND LD TIME)		
		.T4	PREMIUM SMOOTH METALLIC TRIM COLORS		
		.PA	PLATINUM		
		.CLK	CAPTURE - SILVER LOCK		
		.T	KEY ALIKE (MUST ORDER CLCK)		
			TRENDWAY CORPORATION		
			Line Number: 1		
			List Price: 1438.00		
			Discount Off List: 46.00 %		
			Introduced on: March 25, 2014		
			Adopted on: March 25, 2014		
			Official Resolution#: R20140246		



11-12 44th Drive  
Long Island City, NY 11101  
P.718.729.5222 F.718.729.7477

DATE	PROPOSAL#
03/04/14	9729B

PROJECT#: 030-000010

<b>CUSTOMER:</b>
PASSAIC COUNTY 401 GRAND STREET RM# 524  PATTERSON NJ 07505 PH# 973 881 4424973 742

<b>INSTALL AT:</b>
PASSAIC COUNTY 401 GRAND STREET PATTERSON NJ 07505

FAX NUMBER#                      CUSTOMER P.O.#                      SALESPERSON                      TERMS                      SHIP VIA  
  
E. VELASQUEZ-FURN NET 30

#	QTY	PRODUCT	DESCRIPTION	SELL EACH	SELL EXTEND
2	1	CCK07 .T4 .PA .1	CORNER CONNECTOR KIT, 43H PREMIUM SMOOTH METALLIC TRIM COLORS PLATINUM TRIM IS MATCHED UNLESS GO WOOD TRENDWAY CORPORATION Line Number: 2 List Price: 165.00 Discount Off List: 49.00 %	84.15	84.15
3	1	CPD1 .PA	POWER DUPLEX RECEPTACLE, 6/PKG, CIRCUIT I PLATINUM TRENDWAY CORPORATION Line Number: 3 List Price: 141.00 Discount Off List: 49.00 %	71.91	71.91
4	1	EBFH	ELECTRICAL BASE FEED HARNESS 72"  TRENDWAY CORPORATION Line Number: 4 List Price: 166.00 Discount Off List: 49.00 %	84.66	84.66
5	1	EPEC07 .1 .PA	ENTRY PANEL END COVER, 43" HIGH PAINTED END COVER PLATINUM TRENDWAY CORPORATION Line Number: 5 List Price: 74.00 Discount Off List: 49.00 %	37.74	37.74

Introduced on:     March 25, 2014  
Adopted on:        March 25, 2014  
Official Resolution#: R20140246

PROPOSAL



11-12 44th Drive  
 Long Island City, NY 11101  
 P.718.729.5222 F.718.729.7477

DATE	PROPOSAL#
03/04/14	9729B

PROJECT#: 030-000010

<b>CUSTOMER:</b>
PASSAIC COUNTY 401 GRAND STREET RM# 524  PATTERSON NJ 07505 PH# 973 881 4424973 742

<b>INSTALL AT:</b>
PASSAIC COUNTY 401 GRAND STREET PATTERSON NJ 07505

FAX NUMBER#                      CUSTOMER P.O.#                      SALESPERSON                      TERMS                      SHIP VIA

E. VELASQUEZ-FURN NET 30

#	QTY	PRODUCT	DESCRIPTION	SELL EACH	SELL EXTEND
6	4	FR3607	SYSTEMS FRAME, 43H X 36W	170.34	681.36
		.T4	PREMIUM SMOOTH METALLIC TRIM COLORS		
		.PA	PLATINUM		
		.1	TRIM IS MATCHED UNLESS GO WOOD		
			TRENDWAY CORPORATION		
			Line Number: 6		
			List Price: 334.00		
			Discount Off List: 49.00 %		
7	4	LT3604SPCL	LAMINATE TILES SPCL, 36W X 24H	140.25	561.00
		.GR1L	GRADE 1 LAMINATES		
		.8	WILSONART WOOD GRAIN LAMINATES		
		.JOD	BRAZILWOOD		
		.WE	BRAZILWOOD		
			TRENDWAY CORPORATION		
			Line Number: 7		
			List Price: 275.00		
			Discount Off List: 49.00 %		
8	4	PDT3601B	POWER DATA TILE W/ BRACKET, 36W X 6H	111.69	446.76
		.T4	PREMIUM SMOOTH METALLIC TRIM COLORS		
		.PA	PLATINUM		
			TRENDWAY CORPORATION		
			Line Number: 8		
			List Price: 219.00		
			Discount Off List: 49.00 %		
9	1	PEC07	PANEL END COVER, 43" HIGH	30.60	30.60
		.1	PAINTED END COVER		
		.PA	PLATINUM		
			TRENDWAY CORPORATION		
			Line Number: 9		
			List Price: 60.00		
			CONTINUED...		

Introduced on: March 25, 2014  
 Adopted on: March 25, 2014  
 Official Resolution#: R20140246





11-12 44th Drive  
Long Island City, NY 11101  
P.718.729.5222 F.718.729.7477

DATE	PROPOSAL#
03/04/14	9729B

PROJECT#: 030-000010

<b>CUSTOMER:</b>
PASSAIC COUNTY 401 GRAND STREET RM# 524  PATTERSON NJ 07505 PH# 973 881 4424973 742

<b>INSTALL AT:</b>
PASSAIC COUNTY 401 GRAND STREET PATTERSON NJ 07505

FAX NUMBER#                      CUSTOMER P.O.#                      SALESPERSON                      TERMS                      SHIP VIA  
  
E. VELASQUEZ--FURN NET 30

#	QTY	PRODUCT	DESCRIPTION	SELL EACH	SELL EXTEND
			Discount Off List: 49.00 %		
10	3	PPB24	POWERPAC BLOCK, 24" WIDE	51.00	153.00
			TRENDWAY CORPORATION Line Number: 10 List Price: 100.00 Discount Off List: 49.00 %		
11	1	PPC20	CONTRADA POWERPAC CONNECTOR FOR BLK TO BLK BOND 20W	43.86	43.86
			TRENDWAY CORPORATION Line Number: 11 List Price: 86.00 Discount Off List: 49.00 %		
12	1	PPC84	CONTRADA POWERPAC CONNECTOR FOR BLK TO BLK BOND 84W	65.28	65.28
			TRENDWAY CORPORATION Line Number: 12 List Price: 128.00 Discount Off List: 49.00 %		
13	2	RCC48.2B	RECTANGULAR COUNTER CAP 48", 2"H BRACKETS	207.57	415.14
		.1	LAMINATE TOP/VINYL EDGE		
		.GR1L	GRADE 1 LAMINATES		
		.8	WILSONART WOOD GRAIN LAMINATES		
		.J0D	BRAZILWOOD		
		.Y	SAND		
		.T4	PREMIUM SMOOTH METALLIC TRIM COLORS		
			CONTINUED...		
Introduced on:		March 25, 2014			
Adopted on:		March 25, 2014			
Official Resolution#:		R20140246			

PROPOSAL

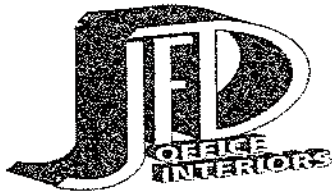

11-12 44th Drive  
 Long Island City, NY 11101  
 P.718.729.5222 F.718.729.7477

DATE	PROPOSAL#
03/04/14	9729B

PROJECT#: 030-000010

<b>CUSTOMER:</b>
PASSAIC COUNTY 401 GRAND STREET RM# 524  PATTERSON NJ 07505 PH# 973 881 4424973 742

<b>INSTALL AT:</b>
PASSAIC COUNTY 401 GRAND STREET PATTERSON NJ 07505

FAX NUMBER#                      CUSTOMER P.O.#                      SALESPERSON                      TERMS                      SHIP VIA

E. VELASQUEZ-FURN NET 30

#	QTY	PRODUCT	DESCRIPTION	SELL EACH	SELL EXTEND
		.PA	PLATINUM TRENDWAY CORPORATION Line Number: 13 List Price: 407.00 Discount Off List: 49.00 %		
14	1	SBR	CONTRADA SUPPORT BRACKET, RIGHT, CHARCOAL ONLY  TRENDWAY CORPORATION Line Number: 14 List Price: 29.00 Discount Off List: 49.00 %	14.79	14.79
15	1	SPECIAL-NOP T	CONTROL #14-141818 CBLEG24 13"D (FOR A 24" DEEP SURFACE) TRI  .T4                      PREMIUM SMOOTH METALLIC TRIM COLORS .PA                      PLATINUM TRENDWAY CORPORATION Line Number: 15 List Price: 710.00 Discount Off List: 46.00 %	383.40	383.40
16	1	TRGLCNPB1	TRIG LEG TO CONTRADA PANEL PARALLEL BRACKET  .T4                      PREMIUM SMOOTH METALLIC TRIM COLORS .PA                      PLATINUM TRENDWAY CORPORATION Line Number: 16 List Price: 144.00 Discount Off List: 46.00 %	77.76	77.76

Introduced on:    March 25, 2014  
 Adopted on:     March 25, 2014  
 Official Resolution#: R20140246



11-12 44th Drive  
 Long Island City, NY 11101  
 P.718.729.5222 F.718.729.7477

DATE	PROPOSAL#
03/04/14	9729B

PROJECT#: 030-000010

**CUSTOMER:**

PASSAIC COUNTY  
 401 GRAND STREET RM# 524

PATTERSON NJ 07505  
 PH# 973 881 4424973 742

**INSTALL AT:**

PASSAIC COUNTY  
 401 GRAND STREET  
 PATTERSON NJ 07505

FAX NUMBER#                      CUSTOMER P.O.#                      SALESPERSON                      TERMS                      SHIP VIA

E. VELASQUEZ-FURN NET 30

#	QTY	PRODUCT	DESCRIPTION	SELL EACH	SELL EXTEND
17	1	WR2472X	RECTANGULAR WORK SURFACE, 24D X 72W X 1-1/4H	257.04	257.04
		.1	LAMINATE TOP/VINYL EDGE		
		.GR1L	GRADE 1 LAMINATES		
		.5	WILSONART TIGRIS LAMINATES		
		.JN2	GREY TIGRIS		
		.Y	SAND		
			TRENDWAY CORPORATION Line Number: 17 List Price: 504.00 Discount Off List: 49.00 %		
18	4	TRGSCNPB	TRIG STORAGE TO CONTRADA PANEL BRACKET	73.98	295.92
			TRENDWAY CORPORATION Line Number: 18 List Price: 137.00 Discount Off List: 46.00 %		
19	1	TRGULEG24	TRIG WORKSURFACE SUPPORT LEG, 24"W	156.60	156.60
		.T4	PREMIUM SMOOTH METALLIC TRIM COLORS		
		.PA	PLATINUM		
			TRENDWAY CORPORATION Line Number: 19 List Price: 290.00 Discount Off List: 46.00 %		
20	4	TT3602	TACKABLE TILE, 36W X 12H	44.88	179.52
		.G3N	GRD 2 OVERTURE		
		.B36	CHIFFON		
			TRENDWAY CORPORATION Line Number: 20 List Price: 88.00 CONTINUED...		

Introduced on: March 25, 2014  
 Adopted on: March 25, 2014  
 Official Resolution#: R20140246

PROPOSAL



11-12 44th Drive  
 Long Island City, NY 11101  
 P.718.729.5222 F.718.729.7477

DATE	PROPOSAL#
03/04/14	9729B

PROJECT#: 030-000010

<b>CUSTOMER:</b>
PASSAIC COUNTY 401 GRAND STREET RM# 524  PATTERSON NJ 07505 PH# 973 881 4424973 742

<b>INSTALL AT:</b>
PASSAIC COUNTY 401 GRAND STREET PATTERSON NJ 07505

FAX NUMBER#                      CUSTOMER P.O.#                      SALESPERSON                      TERMS                      SHIP VIA

E. VELASQUEZ-FURN NET 30

#	QTY	PRODUCT	DESCRIPTION	SELL EACH	SELL EXTEND
			Discount Off List: 49.00 %		
21	4	VT3601 .M1	VENEER TILES, 36W X 6H FONTHILL PEAR (EXTND LD TIME) TRENDWAY CORPORATION Line Number: 21 List Price: 234.00 Discount Off List: 49.00 %	119.34	477.36
22	4	VT3606 .M1	VENEER TILES, 36W X 36H FONTHILL PEAR (EXTND LD TIME) TRENDWAY CORPORATION Line Number: 22 List Price: 442.00 Discount Off List: 49.00 %	225.42	901.68
23	1	ZFP6612 .MM .1 .1B .XZE .1B .XZE .T	INT LAMINATE MODULAR PEDESTAL, 6/6/12 MOD2 APPLIED PULL GRADE 1 HIGHEST GRADE THERMOFUSED LAMINATE UNIT GRD1 WOOD GRAIN THERMOFUSED LAMINATES BRAZILWOOD (EXTND LD TIME) DRAWER GRD1 WOOD GRAIN THERMOFUSED LAMINATES BRAZILWOOD (EXTND LD TIME) KEY-ALIKE (MUST ORDER ZFLCK) TRENDWAY CORPORATION Line Number: 23 List Price: 705.00 Discount Off List: 46.00 %	380.70	380.70
24	2	CBFLAT36 .MM	CAPTURE BENCH HGT, 12 LAT, 20"D X 36"W MOD2 APPLIED PULL CONTINUED...	776.52	1,553.04
Introduced on:		March 25, 2014			
Adopted on:		March 25, 2014			
Official Resolution#:		R20140246			



11-12 44th Drive  
 Long Island City, NY 11101  
 P.718.729.5222 F.718.729.7477

DATE	PROPOSAL#
03/04/14	9729B

PROJECT#: 030-000010

CUSTOMER: -

PASSAIC COUNTY  
 401 GRAND STREET RM# 524

PATTERSON NJ 07505  
 PH# 973 881 4424973 742

INSTALL AT:

PASSAIC COUNTY  
 401 GRAND STREET  
 PATTERSON NJ 07505

FAX NUMBER#                      CUSTOMER P.O.#                      SALESPERSON                      TERMS                      SHIP VIA

E. VELASQUEZ-FURN NET 30

#	QTY	PRODUCT	DESCRIPTION	SELL EACH	SELL EXTEND
		.1	GRIL HIGHEST GRADE THERMOFUSED LAMINATE		
		.1B	UNIT GRIL WOOD GRAIN THERMOFUSED LAMINATES		
		.XZE	BRAZILWOOD (EXTND LD TIME)		
		.1B	TOP GRIL WOOD GRAIN THERMOFUSED LAMINATES		
		.XZE	BRAZILWOOD (EXTND LD TIME)		
		.1B	GRIL WOODGRAIN VINYL EDGE COLORS		
		.XZE	BRAZILWOOD (EXTND LD TIME)		
		.1B	DRAWER GRD1 WOOD GRAIN THERMOFUSED LAMINATES		
		.XZE	BRAZILWOOD (EXTND LD TIME)		
		.T4	PREMIUM SMOOTH METALLIC TRIM COLORS		
		.PA	PLATINUM		
		.CLK	CAPTURE - SILVER LOCK		
		.T	KEY ALIKE (MUST ORDER CLCK)		
			TRENDWAY CORPORATION		
			Line Number: 24		
			List Price: 1438.00		
			Discount Off List: 46.00 %		
25	1	CPD1	POWER DUPLEX RECEPTACLE,	71.91	71.91
			6/PKG, CIRCUIT I		
		.PA	PLATINUM		
			TRENDWAY CORPORATION		
			Line Number: 25		
			List Price: 141.00		
			Discount Off List: 49.00 %		
26	1	EBFH	ELECTRICAL BASE FEED HARNESS	84.66	84.66
			72"		
			TRENDWAY CORPORATION		
			Line Number: 26		
			List Price: 166.00		
			Discount Off List: 49.00 %		

Introduced on: March 25, 2014  
 Adopted on: March 25, 2014  
 Official Resolution#: R20140246

PROPOSAL



11-12 44th Drive  
 Long Island City, NY 11101  
 P.718.729.5222 F.718.729.7477

DATE	PROPOSAL#
03/04/14	9729B

PROJECT#: 030-000010

<b>CUSTOMER:</b>
PASSAIC COUNTY 401 GRAND STREET RM# 524  PATTERSON NJ 07505 PH# 973 881 4424973 742

<b>INSTALL AT:</b>
PASSAIC COUNTY 401 GRAND STREET PATTERSON NJ 07505

FAX NUMBER#                      CUSTOMER P.O.#                      SALESPERSON                      TERMS                      SHIP VIA  
 E. VELASQUEZ-FURN NET 30

#	QTY	PRODUCT	DESCRIPTION	SELL EACH	SELL EXTEND
27	1	EPEC07	ENTRY PANEL END COVER, 43" HIGH	37.74	37.74
		.1	PAINTED END COVER		
		.PA	PLATINUM		
			TRENDWAY CORPORATION Line Number: 27 List Price: 74.00 Discount Off List: 49.00 %		
28	2	FR3607	SYSTEMS FRAME, 43H X 36W	170.34	340.68
		.T4	PREMIUM SMOOTH METALLIC TRIM COLORS		
		.PA	PLATINUM		
		.1	TRIM IS MATCHED UNLESS GO WOOD		
			TRENDWAY CORPORATION Line Number: 28 List Price: 334.00 Discount Off List: 49.00 %		
29	1	FR4807	SYSTEMS FRAME, 43H X 48W	196.35	196.35
		.T4	PREMIUM SMOOTH METALLIC TRIM COLORS		
		.PA	PLATINUM		
		.1	TRIM IS MATCHED UNLESS GO WOOD		
			TRENDWAY CORPORATION Line Number: 29 List Price: 385.00 Discount Off List: 49.00 %		
30	2	LT3604SPCL	LAMINATE TILES SPCL, 36W X 24H	140.25	280.50
		.GR1L	GRADE 1 LAMINATES		
		.8	WILSONART WOOD GRAIN LAMINATES		
		.JOD	BRAZILWOOD		
		.WE	BRAZILWOOD		
			TRENDWAY CORPORATION Line Number: 30 CONTINUED...		

Introduced on: March 25, 2014  
 Adopted on: March 25, 2014  
 Official Resolution#: R20140246



11-12 44th Drive  
 Long Island City, NY 11101  
 P.718.729.5222 F.718.729.7477

DATE	PROPOSAL#
03/04/14	9729B

PROJECT#: 030-000010

<b>CUSTOMER:</b>
PASSAIC COUNTY 401 GRAND STREET RM# 524  PATTERSON NJ 07505 PH# 973 881 4424973 742

<b>INSTALL AT:</b>
PASSAIC COUNTY 401 GRAND STREET PATTERSON NJ 07505

FAX NUMBER#                      CUSTOMER P.O.#                      SALESPERSON                      TERMS                      SHIP VIA  
 E. VELASQUEZ-FURN NET 30

#	QTY	PRODUCT	DESCRIPTION	SELL EACH	SELL EXTEND
			List Price: 275.00 Discount Off List: 49.00 %		
31	1	LT4804SPCL	LAMINATE TILES SPCL, 48W X 24H	156.57	156.57
		.GR1L	GRADE 1 LAMINATES		
		.8	WILSONART WOOD GRAIN LAMINATES		
		.J0D	BRAZILWOOD		
		.WE	BRAZILWOOD		
			TRENDWAY CORPORATION Line Number: 31 List Price: 307.00 Discount Off List: 49.00 %		
32	2	PDT3601B	POWER DATA TILE W/ BRACKET, 36W X 6H	111.69	223.38
		.T4	PREMIUM SMOOTH METALLIC TRIM COLORS		
		.PA	PLATINUM		
			TRENDWAY CORPORATION Line Number: 32 List Price: 219.00 Discount Off List: 49.00 %		
33	1	PDT4801B	POWER DATA TILE W/ BRACKET, 48W X 6H	119.34	119.34
		.T4	PREMIUM SMOOTH METALLIC TRIM COLORS		
		.PA	PLATINUM		
			TRENDWAY CORPORATION Line Number: 33 List Price: 234.00 Discount Off List: 49.00 %		

Introduced on: March 25, 2014  
 Adopted on: March 25, 2014  
 Official Resolution#: R20140246

PROPOSAL



11-12 44th Drive  
 Long Island City, NY 11101  
 P.718.729.5222 F.718.729.7477

DATE	PROPOSAL#
03/04/14	9729B

PROJECT#: 030-000010

<b>CUSTOMER:</b>
PASSAIC COUNTY 401 GRAND STREET RM# 524  PATTERSON NJ 07505 PH# 973 881 4424973 742

<b>INSTALL AT:</b>
PASSAIC COUNTY 401 GRAND STREET PATTERSON NJ 07505

FAX NUMBER#                      CUSTOMER P.O.#                      SALESPERSON                      TERMS                      SHIP VIA  
 E. VELASQUEZ-FURN NET 30

#	QTY	PRODUCT	DESCRIPTION	SELL EACH	SELL EXTEND
34	1	PEC07 .1 .PA	PANEL END COVER, 43" HIGH PAINTED END COVER PLATINUM TRENDWAY CORPORATION Line Number: 34 List Price: 60.00 Discount Off List: 49.00 %	30.60	30.60
35	2	PPB24	POWERPAC BLOCK, 24" WIDE  TRENDWAY CORPORATION Line Number: 35 List Price: 100.00 Discount Off List: 49.00 %	51.00	102.00
36	1	PPB48	POWERPAC BLOCK, MAX 4-20AMP CIRS/4 DPLX RCPTS, 48W  TRENDWAY CORPORATION Line Number: 36 List Price: 100.00 Discount Off List: 49.00 %	51.00	51.00
37	1	PPC20	CONTRADA POWERPAC CONNECTOR FOR BLK TO BLK BOND 20W  TRENDWAY CORPORATION Line Number: 37 List Price: 86.00 Discount Off List: 49.00 %	43.86	43.86
38	1	PPC36	CONTRADA POWERPAC CONNECTOR FOR BLK TO BLK BOND 36W  TRENDWAY CORPORATION	51.00	51.00

Introduced on:     March 25, 2014  
 Adopted on:        March 25, 2014  
 Official Resolution#: R20140246

CONTINUED...





11-12 44th Drive  
Long Island City, NY 11101  
P.718.729.5222 F.718.729.7477

DATE	PROPOSAL#
03/04/14	9729B

PROJECT#: 030-000010

<b>CUSTOMER:</b>
PASSAIC COUNTY 401 GRAND STREET RM# 524  PATTERSON NJ 07505 PH# 973 881 4424973 742

<b>INSTALL AT:</b>
PASSAIC COUNTY 401 GRAND STREET PATTERSON NJ 07505

FAX NUMBER#                      CUSTOMER P.O.#                      SALESPERSON                      TERMS                      SHIP VIA  
  
E. VELASQUEZ-FURN NET 30

#	QTY	PRODUCT	DESCRIPTION	SELL EACH	SELL EXTEND
			Line Number: 38 List Price: 100.00 Discount Off List: 49.00 %		
39	1	RCC48.2B	RECTANGULAR COUNTER CAP 48", 2"H BRACKETS .1 LAMINATE TOP/VINYL EDGE .GR1L GRADE 1 LAMINATES .8 WILSONART WOOD GRAIN LAMINATES .J0D BRAZILWOOD .Y SAND .T4 PREMIUM SMOOTH METALLIC TRIM COLORS .PA PLATINUM TRENDWAY CORPORATION Line Number: 39 List Price: 407.00 Discount Off List: 49.00 %	207.57	207.57
40	1	SBL	CONTRADA SUPPORT BRACKET, LEFT, CHARCOAL ONLY TRENDWAY CORPORATION Line Number: 40 List Price: 29.00 Discount Off List: 49.00 %	14.79	14.79
41	1	SPECIAL-NOP T	CONTROL #14-141818 CBLEG24 13"D (FOR A 24" DEEP SURFACE) TRI .T4 PREMIUM SMOOTH METALLIC TRIM COLORS .PA PLATINUM TRENDWAY CORPORATION Line Number: 41 CONTINUED...	383.40	383.40
Introduced on:		March 25, 2014			
Adopted on:		March 25, 2014			
Official Resolution#:		R20140246			

PROPOSAL



11-12 44th Drive  
 Long Island City, NY 11101  
 P.718.729.5222 F.718.729.7477

DATE	PROPOSAL#
03/04/14	9729B

PROJECT#: 030-000010

<b>CUSTOMER:</b>
PASSAIC COUNTY 401 GRAND STREET RM# 524  PATTERSON NJ 07505 PH# 973 881 4424973 742

<b>INSTALL AT:</b>
PASSAIC COUNTY 401 GRAND STREET PATTERSON NJ 07505

FAX NUMBER#                      CUSTOMER P.O.#                      SALESPERSON                      TERMS                      SHIP VIA

E. VELASQUEZ--FURN NET 30

#	QTY	PRODUCT	DESCRIPTION	SELL EACH	SELL EXTEND
			List Price: 710.00 Discount Off List: 46.00 %		
42	1	TRGLCNPB1	TRIG LEG TO CONTRADA PANEL PARALLEL BRACKET .T4 PREMIUM SMOOTH METALLIC TRIM COLORS .PA PLATINUM TRENDWAY CORPORATION Line Number: 42 List Price: 144.00 Discount Off List: 46.00 %	77.76	77.76
43	1	WR2472X	RECTANGULAR WORK SURFACE, 24D X 72W X 1-1/4H .1 LAMINATE TOP/VINYL EDGE .GR1L GRADE 1 LAMINATES .5 WILSONART TIGRIS LAMINATES .JN2 GREY TIGRIS .Y SAND TRENDWAY CORPORATION Line Number: 43 List Price: 504.00 Discount Off List: 49.00 %	257.04	257.04
44	4	TRGSCNPB	TRIG STORAGE TO CONTRADA PANEL BRACKET  TRENDWAY CORPORATION Line Number: 44 List Price: 137.00 Discount Off List: 46.00 %	73.98	295.92

Introduced on: March 25, 2014  
 Adopted on: March 25, 2014  
 Official Resolution#: R20140246



11-12 44th Drive  
 Long Island City, NY 11101  
 P.718.729.5222 F.718.729.7477

DATE	PROPOSAL#
03/04/14	9729B

PROJECT#: 030-000010

<b>CUSTOMER:</b>
PASSAIC COUNTY 401 GRAND STREET RM# 524  PATTERSON NJ 07505 PH# 973 881 4424973 742

<b>INSTALL AT:</b>
PASSAIC COUNTY 401 GRAND STREET PATTERSON NJ 07505

FAX NUMBER#                      CUSTOMER P.O.#                      SALESPERSON                      TERMS                      SHIP VIA  
 E. VELASQUEZ-FURN NET 30

#	QTY	PRODUCT	DESCRIPTION	SELL EACH	SELL EXTEND
45	1	TRGULEG20	TRIG WORKSURFACE SUPPORT LEG, 20"W .T4 PREMIUM SMOOTH METALLIC TRIM COLORS .PA PLATINUM TRENDWAY CORPORATION Line Number: 45 List Price: 290.00 Discount Off List: 46.00 %	156.60	156.60
46	2	TT3602	TACKABLE TILE, 36W X 12H .G3N GRD 2 OVERTURE .B36 CHIFFON TRENDWAY CORPORATION Line Number: 46 List Price: 88.00 Discount Off List: 49.00 %	44.88	89.76
47	1	TT4802	TACKABLE TILE, 48W X 12H .G3N GRD 2 OVERTURE .B36 CHIFFON TRENDWAY CORPORATION Line Number: 47 List Price: 112.00 Discount Off List: 49.00 %	57.12	57.12
48	2	VT3601	VENEER TILES, 36W X 6H .M1 FONTHILL PEAR (EXTND LD TIME) TRENDWAY CORPORATION Line Number: 48 List Price: 234.00 Discount Off List: 49.00 %	119.34	238.68
49	2	VT3606	VENEER TILES, 36W X 36H .M1 FONTHILL PEAR (EXTND LD TIME) TRENDWAY CORPORATION	225.42	450.84

CONTINUED...

Introduced on: March 25, 2014  
 Adopted on: March 25, 2014  
 Official Resolution#: R20140246

PROPOSAL



11-12 44th Drive  
 Long Island City, NY 11101  
 P.718.729.5222 F.718.729.7477

DATE	PROPOSAL#
03/04/14	9729B

PROJECT#: 030-000010

<b>CUSTOMER:</b>
PASSAIC COUNTY 401 GRAND STREET RM# 524  PATTERSON NJ 07505 PH# 973 881 4424973 742

<b>INSTALL AT:</b>
PASSAIC COUNTY 401 GRAND STREET PATTERSON NJ 07505

FAX NUMBER#                      CUSTOMER P.O.#                      SALESPERSON                      TERMS                      SHIP VIA

E. VELASQUEZ-FURN NET 30

#	QTY	PRODUCT	DESCRIPTION	SELL EACH	SELL EXTEND
			Line Number: 49 List Price: 442.00 Discount Off List: 49.00 %		
50	1	VT4801 .M1	VENEER TILES, 48W X 6H FONTHILL PEAR (EXTND LD TIME) TRENDWAY CORPORATION Line Number: 50 List Price: 307.00 Discount Off List: 49.00 %	156.57	156.57
51	1	VT4806 .M1	VENEER TILES, 48W X 36H FONTHILL PEAR (EXTND LD TIME) TRENDWAY CORPORATION Line Number: 51 List Price: 546.00 Discount Off List: 49.00 %	278.46	278.46
52	1	ZFP6612 .MM .1 .1B .XZE .1B .XZE .T	INT LAMINATE MODULAR PEDESTAL, 6/6/12 MOD2 APPLIED PULL GRADE 1 HIGHEST GRADE THERMOFUSED LAMINATE UNIT GRD1 WOOD GRAIN THERMOFUSED LAMINATES BRAZILWOOD (EXTND LD TIME) DRAWER GRD1 WOOD GRAIN THERMOFUSED LAMINATES BRAZILWOOD (EXTND LD TIME) KEY-ALIKE (MUST ORDER ZFLCK) TRENDWAY CORPORATION Line Number: 52 List Price: 705.00 Discount Off List: 46.00 %	380.70	380.70

Introduced on:     March 25, 2014  
 Adopted on:        March 25, 2014  
 Official Resolution#: R20140246



11-12 44th Drive  
 Long Island City, NY 11101  
 P.718.729.5222 F.718.729.7477

DATE	PROPOSAL#
03/04/14	9729B

PROJECT#: 030-000010

<b>CUSTOMER:</b>
PASSAIC COUNTY 401 GRAND STREET RM# 524  PATTERSON NJ 07505 PH# 973 881 4424973 742

<b>INSTALL AT:</b>
PASSAIC COUNTY 401 GRAND STREET PATTERSON NJ 07505

FAX NUMBER#                      CUSTOMER P.O.#                      SALESPERSON                      TERMS                      SHIP VIA  
 E. VELASQUEZ-FURN NET 30

#	QTY	PRODUCT	DESCRIPTION	SELL EACH	SELL EXTEND
53	2	CLCK .101	CAPTURE LOCK CORE & KEYS S101 TRENDWAY CORPORATION Line Number: 53 List Price: 12.00 Discount Off List: 46.00 %	6.48	12.96
54	2	CLCK .102	CAPTURE LOCK CORE & KEYS S102 TRENDWAY CORPORATION Line Number: 54 List Price: 12.00 Discount Off List: 46.00 %	6.48	12.96
55	1	ZFLCK .101	INTRINSIC FREESTANDING CORE/KEY SET S101 TRENDWAY CORPORATION Line Number: 55 List Price: 12.00 Discount Off List: 46.00 %	6.48	6.48
56	1	ZFLCK .102	INTRINSIC FREESTANDING CORE/KEY SET S102 TRENDWAY CORPORATION Line Number: 56 List Price: 12.00 Discount Off List: 46.00 %	6.48	6.48

By signing below you have indicated that you have reviewed and agree to accept JFD Office Interiors Terms & Conditions.

DEPOSIT REQUIRED                      0.00                      SUBTOTAL                      13,779.99

ACCEPTED BY \_\_\_\_\_  
 Introduced on: March 25, 2014  
 Adopted on: March 25, 2014  
 Official Resolution: R20140246

TOTAL                      13,779.99

Trendway's design team has prepared this kitchen drawing. In addition, we have prepared this drawing to show the location of the cabinets and wall space to be covered. The dimensions shown are for the cabinets only. The dimensions for the wall space should be verified by the contractor. The information should be carefully reviewed before construction.

Trendway  
Kitchen Cabinet & Business

Copyright © 2014 Trendway. All rights reserved. This drawing is the property of Trendway. It is not to be reproduced, stored in a retrieval system, or transmitted in any form or by any means, electronic, mechanical, photocopying, recording, or by any information storage and retrieval system, without the prior written permission of Trendway. All other rights reserved.

APPROVED BY: \_\_\_\_\_

DATE: 03-25-2014  
 SCALE: 1/8" = 1'-0"  
 DRAWN BY: JLO  
 SHEET: TOP 1  
 DRAWING SIZE: A

REVISION LEVEL

CUSTOMER
PREAKNESS GOLF CLUBHOUSE
PROJECT
ISOMETRIC FURNITURE LAYOUT
PROJECT NUMBER
14-14270_1
DEALER
OFFICE INTERIOR

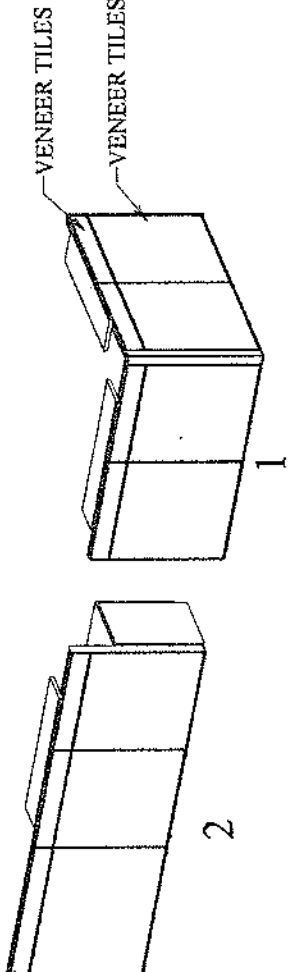
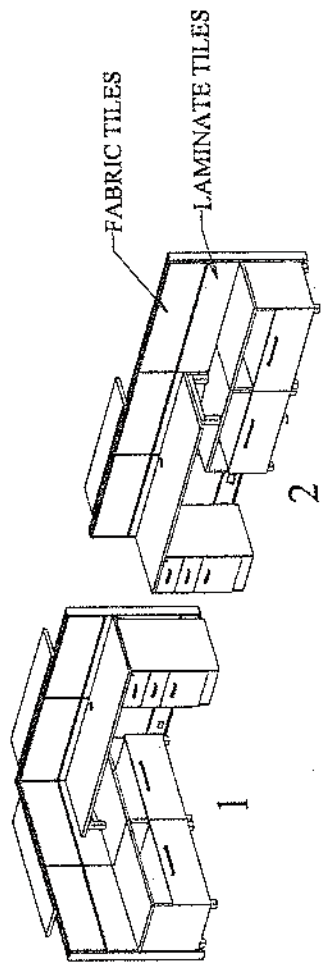

# Passaic County Board of Chosen Freeholders

OFFICE OF THE  
PASSAIC COUNTY FREEHOLDERS

Director Pasquale "Pat" Lepore  
Deputy Director Theodore O. Best, Jr.  
John W. Bartlett  
Ronda Casson Cotroneo  
Terry Duffy  
Bruce James  
Hector C. Lora

401 Grand Street  
Paterson, New Jersey 07505  
Tel: 973-881-4402  
Fax: 973-742-3746

Anthony J. De Nova III  
*Administrator*  
William J. Pascrell, III, Esq.  
*County Counsel*  
Louis E. Imhof, III, RMC  
*Clerk Of The Board*



## Public Meeting (Board Meeting)

Date: Mar 25, 2014 - 5:30 PM

Location: County Administration  
220  
401 Grand Street  
Paterson, NJ 07505

Agenda: RESOLUTION AUTHORIZING PURCHASE OF REPLACEMENT FURNITURE FOR USE AT THE PREAKNESS VALLEY GOLF COURSE CLUB HOUSE IN TOTOWA, NJ THROUGH STATE CONTRACT VENDOR

THIS RESOLUTION WAS REQUESTED BY:

REVIEWED BY:

Anthony J. De Nova III  
COUNTY ADMINISTRATOR

APPROVED AS TO FORM AND LEGALITY:

William J. Pascrell, III, Esq.  
COUNTY COUNSEL

Late Starters

COMMITTEE NAME

<b>Official Resolution#</b>	<b>R20140246</b>						
Meeting Date	03/25/2014						
Introduced Date	03/25/2014						
Adopted Date	03/25/2014						
Agenda Item	I-47						
CAF #	C-04-55-820-000-901						
Purchase Req. #	TBD						
Result	Adopted						
<b>FREEHOLDER</b>	<b>PRES.</b>	<b>ABS.</b>	<b>MOVE</b>	<b>SEC</b>	<b>AYE</b>	<b>NAY</b>	<b>ABST.</b>
Lepore	✓				✓		
Best Jr	✓		✓		✓		
Bartlett	✓			✓	✓		
Cotroneo	✓				✓		
Duffy	✓				✓		
James	✓				✓		
Lora	✓				✓		

PRES.= present ABS.= absent  
MOVE= moved SEC= seconded  
AYE= yes NAY= no ABST.= abstain

Dated: March 26, 2014

**RESOLUTION AUTHORIZING PURCHASE OF  
REPLACEMENT FURNITURE FOR USE AT THE  
PREAKNESS VALLEY GOLF COURSE CLUB HOUSE IN  
TOTOWA, NJ THROUGH STATE CONTRACT VENDOR**

**WHEREAS** the County of Passaic is desirous of renovating the Preakness Valley Golf Course Club House by replacing existing outdated office furniture with new furniture, including workstations through State Contract G-2004 for a total amount of \$25,261.92 from JFD Office Interiors of Long Island City, NY as indicated in more detail in the attached correspondence dated March 21, 2014; and

**WHEREAS** the Board of Chosen Freeholders is desirous of approving said request in accordance with the terms of the State Contract and authorizing the Purchasing Agent to issue the appropriate Purchase Order; and

**WHEREAS** the Public Works and Buildings & Grounds Committee has considered this matter at the March 24, 2014 meeting and recommended this resolution to the full Board for adoption; and

**WHEREAS** a certification is attached indicating that funds are available for the above contemplated expenditure; and

**NOW THEREFORE BE IT RESOLVED** by the Board of Chosen Freeholders of the County of Passaic that it hereby authorizes the purchase of said replacement furniture described above and in the attached correspondence in



accordance with the terms of the applicable State Contract;  
and

**BE IT FURTHER RESOLVED** that the Purchasing Agent and all other necessary officers and employees be and hereby are authorized and directed to take such further actions and sign such documents as are necessary to effectuate the purpose of this resolution, including but not limited to issuance of an appropriate Purchase Order.

Dated: March 25, 2014