

## **PUBLIC NOTICE**

**PLEASE TAKE NOTICE:** The Board of County Commissioners of the County of Passaic adopted Resolution No. R20210001 at its January 7, 2021 meeting setting the regular meeting schedule for calendar year 2021 in compliance with N.J.S.A. 10:4-18 to take place at the following dates and times:

January 26, 2021 at 5:30 PM  
February 9, 2021 at 5:30 PM  
February 23, 2021 at 5:30 PM  
March 9, 2021 at 5:30 PM  
March 23, 2021 at 5:30 PM  
April 13, 2021 at 5:30 PM  
April 27, 2021 at 5:30 PM  
May 11, 2021 at 5:30 PM  
May 25, 2021 at 5:30 PM  
June 8, 2021 at 5:30 PM  
June 22, 2021 at 5:30 PM  
July 20, 2021 at 5:30 PM  
August 10, 2021 at 5:30 PM  
September 8, 2021 at 5:30 PM  
September 28, 2021 at 5:30 PM  
October 12, 2021 at 5:30 PM  
October 26, 2021 at 5:30 PM  
November 9, 2021 at 5:30 PM  
November 23, 2021 at 5:30 PM  
December 14, 2021 at 5:30 PM  
December 28, 2021 at 10:00 AM

Meetings of the Board shall be conducted using electronic equipment on Facebook Live and Cisco WebEx in compliance with the requirements and conditions as set forth in the N.J.S.A. 10:4-9.3, et seq. because of the Public Health Emergency declared by New Jersey Governor Phillip Murphy pursuant to Executive Order No. 103 and renewed thereafter by subsequent executive orders and in compliance with the Board's By-Laws. If a member of the public wishes to place a public comment on the record please email [public@passaiccountynj.org](mailto:public@passaiccountynj.org) stating your name, address, and matter to be addressed by the Board no later than 5:30 PM on the date of the scheduled meeting. The Clerk of the Board shall read same into the public record. Additionally, a member of the public may participate electronically via Cisco WebEx on the date of the meeting at <https://passaiccountynj.org/MeetingofCommissioners> and shall be afforded time to participate in the public portion of the meeting in compliance with the Board's By-Laws. Official action will be taken. This notice is being issued pursuant to the Open Public Meetings Act, P.L. 1975, Chapter 231, N.J.S.A. 10:4-06, et seq.

### **BY ORDER OF THE BOARD OF COUNTY COMMISSIONERS**

---

Louis E. Imhof III, Clerk of the Board

Dated: January 18, 2021

Published in: Herald News  
Bergen Record

On File with the Passaic County Clerk

**Louis E. Imhof III**  
**Clerk of the Board**  
**Board of County Commissioners**  
**County of Passaic**  
**(973) 881-4412 or [Louisi@passaiccountynj.org](mailto:Louisi@passaiccountynj.org)**

# County of Passaic Board of County Commissioners

OFFICE OF COUNTY COMMISSIONERS

Director Pasquale "Pat" Lepore  
Deputy Director Bruce James  
Assad R. Akhter  
John W. Bartlett  
Theodore O. Best, Jr.  
Terry Duffy  
Cassandra "Sandi" Lazzara

401 Grand Street  
Paterson, New Jersey 07505  
Tel: 973-881-4402  
Fax: 973-742-3746

Anthony J. De Nova III  
*Administrator*  
Matthew P. Jordan, Esq.  
*County Counsel*  
Louis E. Imhof, III, RMC  
*Clerk Of The Board*



## Meeting Venue

Date: Aug 10, 2021 - 5:30 PM  
Location: County Administration Building  
Webex - 220  
401 Grand Street  
Paterson, NJ 07505

### A. Roll Call:

1. Akhter
2. Bartlett
3. Best
4. Duffy
5. Lazzara
6. Deputy Director James
7. Director Lepore

### B. Announcement of the Open Public Meeting Law

### C. Invocation:

### D. Pledge of Allegiance

### E. Moment of silence to remember all the men and women who have died while serving in the United States Armed Forces and all who have died from COVID-19, especially the 1,747 residents of Passaic County.

### F. Approval of Minutes: July 20, 2021

G. Approval of Proclamation:

1. The Passaic County Board of County Commissioners wish to congratulate Prophetess Sadie Lee Mills on her 90th birthday.

H. Administrator's Report:

1. Proclamation presented to Ringwood Health Officer Kathleen Skrobala.
2. Update on County of Passaic response to the Covid-19 Pandemic by Dr. Charlene Gungil, Director & Health Officer.

I. County Commissioner Reports:

1. Commissioner Director Pasquale "Pat" Lepore
2. Commissioner Deputy Director Bruce James
3. Commissioner Assad R. Akhter
4. Commissioner John W. Bartlett
5. Commissioner Theodore O. Best, Jr.
6. Commissioner Terry Duffy
7. Commissioner Cassandra "Sandi" Lazzara

J. Communications:

1. Luc's Fajita Hut, Looking to close certain County roads in West Milford, NJ on September 11, 2021, all as noted in the communication.

K. Oral Portion:

1. Motion to Open the Public Portion of the meeting\_\_\_\_\_
2. Motion to Close the Public Portion of the meeting\_\_\_\_\_

L. Consent Agenda:

**ADMINISTRATION AND FINANCE**

1. REQUESTING APPROVAL FOR THE INSERTION OF A SPECIAL ITEM OF REVENUE IN THE 2021 BUDGET PURSUANT TO N.J.S. 40A:4- 87 (Chapter 159 P.L. 148) CDBGCV3, ALL AS NOTED IN THE RESOLUTION.

2. REQUESTING APPROVAL FOR THE INSERTION OF A SPECIAL ITEM OF REVENUE IN THE 2021 BUDGET PURSUANT TO N.J.S. 40A:4- 87 (Chapter 159 P.L. 148) CDBG-COVID-19 CV2, ALL AS NOTED IN THE RESOLUTION.

**ADMINISTRATION AND FINANCE**

3. REQUESTING APPROVAL FOR THE INSERTION OF A SPECIAL ITEM OF REVENUE IN THE 2021 BUDGET PURSUANT TO N.J.S. 40A:4- 87 (Chapter 159 P.L. 148) LBF- High Mtn Rd Culvert, ALL AS NOTED IN THE RESOLUTION.
4. REQUESTING APPROVAL FOR THE INSERTION OF A SPECIAL ITEM OF REVENUE IN THE 2021 BUDGET PURSUANT TO N.J.S. 40A:4- 87 (Chapter 159 P.L. 148) LBF- Pennington Avenue, ALL AS NOTED IN THE RESOLUTION.
5. REQUESTING APPROVAL FOR THE INSERTION OF A SPECIAL ITEM OF REVENUE IN THE 2021 BUDGET PURSUANT TO N.J.S. 40A:4- 87 (Chapter 159 P.L. 148) LBF- Passaic Ave Culvert, ALL AS NOTED IN THE RESOLUTION.
6. RESOLUTION CANCELING UNEXPENDED BALANCES OF ANTICIPATED REVENUE AND APPROPRIATIONS MADE IN THE GRANTFUND, ALL AS NOTED IN THE RESOLUTION
7. RESOLUTION AUTHORIZING A SECOND CONTRACT MODIFICATION WITH NW FINANCIAL GROUP TO ADMINISTER CARES ACT FUNDING FOR THE COUNTY OF PASSAIC, PURSUANT TO N.J.A.C. 5:30-11.6, ET SEQ., ALL AS NOTED IN THE RESOLUTION.
8. RESOLUTION AMENDING THE REGULAR MEETING SCHEDULE FOR THE BOARD OF COUNTY COMMISSIONERS FOR CALENDAR YEAR 2021, PURSUANT TO N.J.S.A. 10:4-18, ALL AS NOTED IN THE RESOLUTION.
9. RESOLUTION AUTHORIZING A MEMORANDUM OF UNDERSTANDING WITH THE NEW JERSEY REENTRY CORPORATION, PURSUANT TO N.J.S.A. 40:20-1, ALL AS NOTED IN THE RESOLUTION.
10. RESOLUTION RETAINING CLEARY GIACOBBE ALFIERI & JACOBS, LLC TO CONDUCT INTERNAL EMPLOYEE INVESTIGATIONS ON AN AS-NEEDED BASIS, PURSUANT TO N.J.S.A. 40A:11-5, ET SEQ., ALL AS NOTED IN THE RESOLUTION.
11. RESOLUTION RETAINING ERIC M. BERNSTEIN & ASSOCIATES, LLC FOR OUTSIDE LEGAL SERVICES IN VARIOUS MATTERS, PURSUANT TO N.J.S.A. 40A:11-5, ET SEQ., ALL AS NOTED IN THE RESOLUTION.

12. RESOLUTION AUTHORIZING THE PURCHASE OF SOFTWARE FOR ELEARNING SUBSCRIPTIONS FOR VARIOUS SOFTWARE USED BY COUNTY EMPLOYEES FROM SHI INTERNATIONAL CORP., PURSUANT TO N.J.S.A. 40A:11-10, ET SEQ., ALL AS NOTED IN THE RESOLUTION.

#### **ADMINISTRATION AND FINANCE**

13. RESOLUTION AUTHORIZING A THIRD AMENDMENT TO THE OMNIBUS PURCHASING RESOLUTION FOR CALENDAR YEAR 2021, PURSUANT TO N.J.S.A. 40A:11-12, ET SEQ., ALL AS NOTED IN THE RESOLUTION.
14. RESOLUTION AUTHORIZING THE CHIEF FINANCIAL OFFICER TO EXECUTE BUDGET TRANSFERS BETWEEN PREVIOUSLY-APPROVED OPEN SPACE, FARMLAND, AND HISTORIC PRESERVATION TRUST FUND BUDGETS, PURSUANT TO N.J.S.A. 40:20-1, ALL AS NOTED IN THE RESOLUTION.
15. RESOLUTION AUTHORIZING ADDITIONAL LEGAL FEE AUTHORIZATION FOR HOAGLAND LONGO MORAN DUNST & DUKAS, LLP IN JACKSON V. COUNTY OF PASSAIC, ET AL, DOCKET NO. BER-L-004351-21, PURSUANT TO N.J.A.C. 5:30-11.6, ALL AS NOTED IN THE RESOLUTION.
16. RESOLUTION AUTHORIZING THE SETTLEMENT OF LITIGATION ENTITLED, JOHN PIERSON V. COUNTY OF PASSAIC, CLAIM PETITION NO. 2011-34209, PENDING IN THE NEW JERSEY DIVISION OF WORKERS' COMPENSATION, PURSUANT TO N.J.S.A. 40:20-1, ALL AS NOTED IN THE RESOLUTION.
17. RESOLUTION AUTHORIZING THE CREATION OF THE PASSAIC COUNTY JAIL ASSESSMENT COMMITTEE; DIRECTING THE COUNTY ADMINISTRATOR TO EXPLORE OPTIONS RELATED TO SAME, INCLUDING REBUILDING OR CONSOLIDATING THE OPERATIONS OF THE PASSAIC COUNTY JAIL, PURSUANT TO N.J.S.A. 40A:65-1, ET SEQ., ALL AS NOTED IN THE RESOLUTION.

#### **HEALTH & HUMAN SERVICES**

18. RESOLUTION AUTHORIZING AN AWARD OF CONTRACT TO BIG BELLY SOLAR, LLC TO RENEW SUPPORT SERVICES FOR PROPRIETARY SOFTWARE FOR THE COUNTY OF PASSAIC, PURSUANT TO N.J.S.A. 40A:11-3, ET SEQ. AND N.J.S.A. 40A:11-5(1)(dd), ALL AS NOTED IN THE RESOLUTION.
19. RESOLUTION AUTHORIZING THE DEPARTMENT OF HEALTH TO APPLY FOR AND ACCEPT A GRANT FROM THE STATE OF NEW JERSEY, DEPARTMENT OF HEALTH FOR THE CHILDHOOD LEAD PROGRAM, PURSUANT TO N.J.S.A. 40:20-1 ET SEQ., ALL AS NOTED IN THE RESOLUTION., ALL AS NOTED IN THE RESOLUTION.
20. RESOLUTION AUTHORIZING AN AWARD OF CONTRACT TO THERMOFISHER SCIENTIFIC FOR LEAD ANALYZING EQUIPMENT, PURSUANT TO N.J.S.A. 40A:11-3, ET SEQ., ALL AS NOTED IN THE RESOLUTION.

## **HEALTH & HUMAN SERVICES**

21. RESOLUTION AUTHORIZING THE PURCHASE OF COVID-19 INFORMATION PACKETS FOR DISTRIBUTION AT TESTING SITES FROM STEWART BUSINESS SYSTEMS, PURSUANT TO N.J.S.A. 40A:11-12, ET SEQ., ALL AS NOTED IN THE RESOLUTION.
  
22. RESOLUTION AUTHORIZING AN AWARD OF CONTRACT TO FC CARES, INC., TO PROVIDE MENTAL HEALTH CRISIS INTERVENTION CONSULTANT SERVICES AND RISK ASSESSMENT INSTRUCTION FOR PASSAIC COUNTY SCHOOLS, PURSUANT TO N.J.S.A. 40A:11-6.1(a), ALL AS NOTED IN THE RESOLUTION.
  
23. RESOLUTION AUTHORIZING THE PASSAIC COUNTY DEPARTMENT OF HUMAN SERVICES TO APPLY FOR AND ACCEPT A GRANT FROM THE STATE OF NEW JERSEY, DEPARTMENT OF LAW AND PUBLIC SAFETY, JUVENILE JUSTICE COMMISSION UNDER THE JUVENILE DETENTION ALTERNATIVES INITIATIVE INNOVATION FUNDING GRANT, PURSUANT TO N.J.S.A. 40:20-1, ET SEQ., ALL AS NOTED IN THE RESOLUTION.
  
24. RESOLUTION INCREASING APPROPRIATION AND APPROVING A FOUR MONTH INCREASE IN CONTRACT TERM TO THE VARIOUS VENDORS UNDER SB-20-035, TO BE USED ON AN AS-NEEDED BASIS BY PREAKNESS HEALTHCARE CENTER FOR MEDICAL AND DENTAL SUPPLIES, PURSUANT TO N.J.S.A. 40A:11-15, ALL AS NOTED IN THE RESOLUTION.
  
25. RESOLUTION AUTHORIZING AN INCREASE IN THE APPROPRIATION TO C.A. SPINELLA, INC. FOR RESIDENTIAL WINDOW AND DOOR REPAIRS AND INSTALLATIONS AND DIVINE ENERGY SOLUTIONS, INC. FOR RESIDENTIAL INSULATION AND VENTILATION REPAIRS AND INTALLATION UNDER THE WEATHERIZATION PROGRAM, PURSUANT TO N.J.S.A 40A:11-15., ALL AS NOTED IN THE RESOLUTION.
  
26. RESOLUTION QUALIFYING A POOL OF LEAD REMEDIATORS AND LEAD ABATEMENT CONTRACTORS AND AWARDING CONTRACTS TO PERFORM LEAD REMEDATION AND LEAD ABATEMENT SERVICES FOR THE DIVISION OF WEATHERIZATION, PURSUANT TO N.J.S.A 40A:11-5 ET SEQ., ALL AS NOTED IN THE RESOLUTION.

## **PUBLIC WORKS**

27. RESOLUTION RENAMING FRIENDSHIP PARK IN THE PASSAIC COUNTY PARK SYSTEM AS THE MAYOR DUNLEAVY MEMORIAL PARK, PURSUANT TO N.J.S.A. 40:20-1, ALL AS NOTED IN THE RESOLUTION.
  
28. RESOLUTION AUTHORIZING AWARD OF CONTRACT TO THE VENDORS LISTED BELOW FOR PAPER GOODS, BAG LINERS, FOOD SERVICE SUPPLY AND RELATED PRODUCTS (BULK PURCHASE) FOR THE COUNTY OF PASSAIC DEPARTMENTS AND INSTITUTIONS AS PER BID SB-21-027 AND PURSUANT TO N.J.S.A. 40A 11-1 ET SEQ., ALL AS NOTED IN THE RESOLUTION.

## PUBLIC WORKS

29. RESOLUTION AUTHORIZING AWARD OF CONTRACT TO THE VENDORS LISTED BELOW FOR JANITORIAL SUPPLIES CATALOG % DISCOUNTS PRICING FOR THE COUNTY OF PASSAIC DEPARTMENTS AND INSTITUTIONS WITH A ONE YEAR OPTION TO RENEW AS PER BID SB-21-053 AND PURSUANT TO N.J.S.A. 40A 11-1 ET SEQ., ALL AS NOTED IN THE RESOLUTION.
  
30. RESOLUTION AUTHORIZING THE PURCHASE OF TWO 2022 FORD F-550 VEHICLES FROM ROUTE 23 AUTOMALL, LLC FOR USE BY THE DIVISION OF ROADS, PURSUANT TO N.J.S.A. 40A:11-12, ET SEQ., ALL AS NOTED IN THE RESOLUTION.
  
31. RESOLUTION AUTHORIZING CHANGE ORDER NO. 2 TO JOHN O'HARA COMPANY INC. FOR THE LAMBERT CASTLE RESTORATION & REHABILITATION PROJECT, PURSUANT TO N.J.A.C. 5:30-11.3 ET SEQ., ALL AS NOTED IN THE RESOLUTION.
  
32. RESOLUTION AUTHORIZING PURCHASE OF SEVEN YAMAHA GOLF UTILITY CARS FROM GOLF CAR SPECIALTIES CATALOG PERCENTAGE DISCOUNT PRICING PURSUANT TO N.J.S.A 40A: 11-1, ET SEQ., ALL AS NOTED IN THE RESOLUTION.
  
33. RESOLUTION AUTHORIZING RIGHT OF WAY ENCROACHMENT PERMIT FOR INSTALLATION OF DIGITAL FIBER OPTIC COMMUNICATION CABINETS FOR ALTICE / CABLEVISION AT VARIOUS LOCATIONS WITHIN THE TOWNSHIP OF WAYNE, NEW JERSEY PURSUANT TO N.J.S.A.40:20-1, ALL AS NOTED IN THE RESOLUTION.
  
34. RESOLUTION AUTHORIZING AWARD OF CONTRACT TO T.R. WENIGER, INC. FOR INSTALLATION OF LOAD BEARING SCREW PILES FOR PREAKNESS VALLEY GOLF COURSE BRIDGES # 6 AND #7, PURSUANT TO N.J.S.A 40A: 11-1, ET SEQ., ALL AS NOTED IN THE RESOLUTION.
  
35. RESOLUTION AUTHORIZING AN AWARD OF CONTRACT TO NEW PRINCE CONCRETE CONSTRUCTION COMPANY, INC., FOR THE REPLACEMENT OF THE RATZER ROAD CULVERT NO. 1600-367 OVER TRIBUTARY TO POMPTON RIVER IN THE TOWNSHIP OF WAYNE, PURSUANT TO N.J.S.A 40A: 11-1, ET SEQ., ALL AS NOTED IN THE RESOLUTION.
  
36. RESOLUTION AUTHORIZING AN AWARD OF CONTRACT TO MURRAY PAVING & CONCRETE, LLC FOR THE COURTHOUSE ANNEX DOOR AND REVERSE PROJECT IN THE CITY OF PATERSON, PURSUANT TO N.J.S.A. 40A:11-10 ET SEQ., ALL AS NOTED IN THE RESOLUTION.

37. RESOLUTION AUTHORIZING AN AWARD OF CONTRACT TO KS ENGINEERS, P.C. FOR THE ENGINEERING DESIGN SERVICES FOR THE REPLACEMENT OF THE OTTERHOLE ROAD CULVERT NO. 1600-148 OVER POST BROOK IN THE TOWNSHIP OF WEST MILFORD, PURSUANT TO N.J.S.A. 40A:11-5, ET SEQ., ALL AS NOTED IN THE RESOLUTION.

#### **PUBLIC WORKS**

38. RESOLUTION AUTHORIZING AN AWARD OF CONTRACT TO COLLIERS ENGINEERING FOR THE ENGINEERING DESIGN SERVICES FOR THE REPLACEMENT OF THE DAWES HIGHWAY BRIDGE NO. 1600-503 OVER RAMAPO RIVER ON THE BORDER OF THE BOROUGH OF POMPTON LAKES AND THE TOWNSHIP OF WAYNE, PURSUANT TO N.J.S.A. 40A:11-5, ET SEQ., ALL AS NOTED IN THE RESOLUTION.
39. RESOLUTION AUTHORIZING THE PURCHASING AGENT TO ADVERTISE AND RECEIVE BIDS FOR INSTALLATION OF EMERGENCY GENERATOR AT 40-60 COLUMBIA AVENUE IN THE CITY OF PATERSON, PURSUANT TO N.J.S.A. 40A:11-1, ET SEQ., ALL AS NOTED IN THE RESOLUTION.
40. RESOLUTION AUTHORIZING THE PURCHASING AGENT TO ADVERTISE AND RECEIVE BIDS FOR THE CHILLERS REPLACEMENT AT 401 GRAND STREET CITY OF PATERSON, PURSUANT TO N.J.S.A. 40A:11-1, ET SEQ., ALL AS NOTED IN THE RESOLUTION.
41. RESOLUTION AUTHORIZING THE PURCHASING AGENT TO ADVERTISE AND RECEIVE BIDS FOR THE RECONSTRUCTION OF PATERSON HAMBURG TURNPIKE & ALPS ROAD INTERSECTION PROJECT IN THE TOWNSHIP OF WAYNE, NEW JERSEY, PURSUANT TO N.J.S.A 40A: 11-1, ET SEQ., ALL AS NOTED IN THE RESOLUTION.
42. RESOLUTION AUTHORIZING THE PURCHASING AGENT TO ADVERTISE AND RECEIVE BIDS FOR THE GARRET MOUNTAIN RESERVATION IMPROVEMENTS PHASE II PROJECT IN THE CITY OF PATERSON AND THE BOROUGH OF WOODLAND PARK, PURSUANT TO N.J.S.A. 40A:11-1, ET SEQ., ALL AS NOTED IN THE RESOLUTION.

#### **LAW AND PUBLIC SAFETY**

43. RESOLUTION AUTHORIZING THE TRANSFER OF A SURPLUS VEHICLE FROM THE PASSAIC COUNTY SHERIFF'S OFFICE FLEET TO WILLIAM PATERSON UNIVERSITY, PURSUANT TO N.J.S.A. 40A:11-36(2), ALL AS NOTED IN THE RESOLUTION.
44. RESOLUTION AUTHORIZING THE PASSAIC COUNTY SHERIFF'S OFFICE TO APPLY FOR AND ACCEPT FUNDS FROM THE STATE OF NEW JERSEY DEPARTMENT OF LAW AND PUBLIC SAFETY OFFICE OF THE ATTORNEY GENERAL SFY21 BODY-WORN CAMERA GRANT PROGRAM, PURSUANT TO N.J.S.A. 40:20-1, ALL AS NOTED IN THE RESOLUTION.
45. RESOLUTION AUTHORIZING PURCHASE OF VARIOUS ITEMS BY THE PASSAIC COUNTY SHERIFF'S OFFICE, PURSUANT TO N.J.S.A. 40A:11-12, ET SEQ., ALL AS NOTED IN THE RESOLUTION.



## **LAW AND PUBLIC SAFETY**

46. RESOLUTION AUTHORIZING THE PASSAIC COUNTY PROSECUTOR'S OFFICE TO APPLY FOR 2021 STATE BODY ARMOR REPLACEMENT FUND GRANT PROGRAM, ALL AS NOTED IN THE RESOLUTION.
  
47. RESOLUTION AUTHORIZING PURCHASE OF COPIER MAINTENANCE SERVICES BY THE PASSAIC COUNTY PROSECUTOR'S OFFICE, PURSUANT TO N.J.S.A. 40A:11-12 ET SEQ., ALL AS NOTED IN THE RESOLUTION.
  
48. RESOLUTION AUTHORIZING THE PASSAIC COUNTY SHERIFF'S OFFICE TO AWARD A CONTRACT TO BIO-REFERENCE LABORATORIES FOR PHARMECUTICAL SERVICES AT THE PASSAIC COUNTY JAIL, PURSUANT TO N.J.S.A. 40A:11-4.1, ET SEQ., ALL AS NOTED IN THE RESOLUTION.
  
49. RESOLUTION AUTHORIZING THE PASSAIC COUNTY SHERIFF'S OFFICE TO HIRE ENTRY LEVEL LAW ENFORCEMENT APPLICANTS WHO MEET THE EXEMPTIONS TO THE CIVIL SERVICE TESTING AS SET FORTH IN P.L. 2021, c. 7, ALL AS NOTED IN THE RESOLUTION.

## **PLANNING AND ECONOMIC DEVELOPMENT**

50. RESOLUTION AUTHORIZING A NO-COST TIME EXTENSION TO 2019 ROUND OF MUNICIPAL AND NON-PROFIT GRANTS FROM THE OPEN SPACE, FARMLAND, AND HISTORIC PRESERVATION TRUST FUND PROGRAM TO THE BOROUGH OF WOODLAND PARK FOR THE DIANE GRIMES MEMORIAL PARK IMPROVEMENTS PROJECT, TO LEVERAGE THE SAID GRANT TO COINCIDE WITH 2020 ROUND OF GRANT FUNDING FOR SAME PROJECT, ALL AS NOTED IN THE RESOLUTION.
  
51. RESOLUTION AUTHORIZING A NO-COST TIME EXTENSION TO 2019 ROUND OF MUNICIPAL AND NON-PROFIT GRANTS FROM THE OPEN SPACE, FARMLAND, AND HISTORIC PRESERVATION TRUST FUND PROGRAM TO THE COMMUNITY ASSOCIATION OF THE HIGHLANDS, RINGWOOD FOR THE UPGRADE AND REHABILITATION OF HIGHLANDS NATURAL POOL TO SPEND DOWN BALANCE OF FUNDS, ALL AS NOTED IN THE RESOLUTION., ALLAS NOTED IN THE RESOLUTION.
  
52. RESOLUTION AUTHORIZING A NO-COST TIME EXTENSION TO 2019 ROUND OF MUNICIPAL AND NON-PROFIT GRANTS FROM THE OPEN SPACE, FARMLAND, AND HISTORIC PRESERVATION TRUST FUND PROGRAM TO THE HIGHLANDS NATURE FRIENDS, INC., FOR REHABILITATION OF THE WEISS CENTER IN RINGWOOD TO ACCOUNT FOR IMPACTS OF COVID-19 ON PERMITTING DELAYS AND DISRUPTIONS TO THE CONTRACTOR, ALL AS NOTED IN THE RESOLUTION.

53. RESOLUTION AUTHORIZING A NO-COST TIME EXTENSION TO 2019 ROUND OF MUNICIPAL AND NON-PROFIT GRANTS FROM THE OPEN SPACE, FARMLAND, AND HISTORIC PRESERVATION TRUST FUND PROGRAM TO THE BOROUGH OF BLOOMINGDALE, WALTER T. BERGEN TENNIS COURT PROJECT, TO ACCOUNT FOR IMPACTS OF COVID-19 ON ADMINISTRATION AND CONSTRUCTION ACTIVITIES, ALL AS NOTED IN THE RESOLUTION.

**PLANNING AND ECONOMIC DEVELOPMENT**

54. RESOLUTION AUTHORIZING A SECOND NO COST TIME EXTENSION FOR THE COMMUNITY DEVELOPMENT BLOCK GRANT PROGRAM FY 2018 WOODLAND PARK LIBRARY AMERICANS WITH DISABILITIES ACT COMPLIANT DOORS PROJECT UNTIL DECEMBER 31, 2021, ALL AS NOTED IN THE RESOLUTION.
55. RESOLUTION AUTHORIZING A NO COST TIME EXTENSION FOR THE COMMUNITY DEVELOPMENT BLOCK GRANT PROGRAM FY 2019 TOWNSHIP OF WEST MILFORD PROJECT TO PROVIDE AMERICANS WITH DISABILITIES ACT ACCESSIBILITY TO THE BATHROOM IN MUNICIPAL BUILDING NO. 1 UNTIL OCTOBER 31, 2021, ALL AS NOTED IN THE RESOLUTION.
56. RESOLUTION AUTHORIZING A NO COST TIME EXTENSION FOR THE COMMUNITY DEVELOPMENT BLOCK GRANT PROGRAM FY 2019 BOROUGH OF BLOOMINGDALE PROJECT TO PROVIDE AMERICANS WITH DISABILITIES ACT ACCESSIBILITY ALONG UNION AVENUE UNTIL DECEMBER 31, 2021, ALL AS NOTED IN THE RESOLUTION.
57. RESOLUTION AUTHORIZING A FIRST NO COST TIME EXTENSION FOR THE COMMUNITY DEVELOPMENT BLOCK GRANT PROGRAM FY 2019 WOODLAND PARK LIBRARY AMERICANS WITH DISABILITIES ACT COMPLIANT BATHROOM PROJECT UNTIL DECEMBER 31, 2021, ALL AS NOTED IN THE RESOLUTION.
58. RESOLUTION AUTHORIZING A NO-COST TIME EXTENSION TO 2019 ROUND OF MUNICIPAL AND NON-PROFIT GRANTS FROM THE OPEN SPACE, FARMLAND, AND HISTORIC PRESERVATION TRUST FUND PROGRAM TO THE WAYNE LITTLE LEAGUE, DOTTERWEICH FIELD AND FACILITY IMPROVEMENTS TO ACCOUNT FOR THE IMPACTS OF COVID-19 AND THE SIGNIFICANT MATERIAL COST INCREASES, ALL AS NOTED IN THE RESOLUTION.
59. RESOLUTION AUTHORIZING A NO-COST TIME EXTENSION TO 2017 ROUND OF MUNICIPAL AND NON-PROFIT GRANTS FROM THE OPEN SPACE, FARMLAND, AND HISTORIC PRESERVATION TRUST FUND PROGRAM TO THE BOROUGH OF HALEDON, BRAEN MEMORIAL/ROE STREET FIELD, DUE TO BID EXCEEDING PROJECT ESTIMATE, ALL AS NOTED IN THE RESOLUTION.

60. RESOLUTION AUTHORIZING AN APPLICATION BY THE COUNTY OF PASSAIC TO THE NEW JERSEY TRANSPORTATION PLANNING AUTHORITY FY23-24 SUBREGIONAL STUDIES PROGRAM GRANT FOR THE PASSAIC COUNTY INFRASTRUCTURE INVESTMENT PLAN FOR \$375,000.00 WITH A CASH MATCH OF \$75,000.00, ALL AS NOTED IN THE RESOLUTION.

**LATE STARTERS**

61. RESOLUTION AUTHORIZING PAYMENT TO GRAYSHIFT, LLC FOR THE PURCHASE OF FORENSIC SOFTWARE TO BE USED BY THE PASSAIC COUNTY PROSECUTOR'S OFFICE, PURSUANT TO N.J.S.A. 40A:11-5, ET SEQ., ALL AS NOTED IN THE RESOLUTION.
  
62. RESOLUTION AUTHORIZING AN APPLICATION TO THE US DEPARTMENT OF INTERIOR OUTDOOR RECREATION LEGACY GRANT PROGRAM FOR THE NORTH PULASKI PARK RENOVATION PROJECT, PURSUANT TO N.J.S.A. 40:20-1, ALL AS NOTED IN THE RESOLUTION.

M. New Business:

1. Personnel:
2. Bills:

N. Adjournment:

**PASSAIC COUNTY BOARD OF COUNTY COMMISSIONERS  
MINUTES FOR REGULAR MEETING HELD ON**

**July 20, 2021**

A regular meeting of the Passaic County Board of County Commissioners was held this day via WebEx at 5:37 PM.

Louis E. Imhof, III, Clerk of the Board, read the announcement on the Open Public Meeting Law.

**Roll Call:**

1. Akhter - Absent
2. Bartlett - Absent
3. Best
4. Duffy
5. Lazzara
6. Deputy Director James
7. Director Lepore

**Invocation:** Louis E. Imhof, III

**Pledge of Allegiance**

**Approval of Minutes:**

Motion made by Deputy Director James, second by County Commissioner Lazzara, that the minutes for June 22, 2021, be approved which the motion was carried on a roll call of five (5) votes in the affirmative with County Commissioners Akhter and Best being absent.

**Proclamations:**

Motion made by County Commissioner Duffy, second by County Commissioner Lazzara, that all proclamations be approved which the motion was carried on a roll call of (5) votes in the affirmative with County Commissioners Akhter and Bartlett being absent.

**Administrator's Report:**

**A proclamation was read into the record for American Disabilities Act.**

**COVID-19 Update:** At this time Passaic County Health officer Dr. Charlene Gungil gave an update on the COVID-19 testing results for the County of Passaic.

Motion made by County Commissioner Duffy, second Deputy Director James, to suspend the regular order of business, which motion was carried on a roll call of five (5) votes in the affirmative with County Commissioners Akhter and Bartlett being absent.

**Bond Ordinance 2021-05**

Director Lepore reported that Bond Ordinance #2021-05 together with notice of this hearing was published as required by law.

Motion made by Deputy Director James, second by County Commissioner Duffy, that the Public Hearing be opened, which motion was carried on a roll call of five (5) votes in the affirmative with County Commissioners Akhter and Bartlett being absent.

Director Lepore asked if there was anyone present who desired to be heard?

At this time no one appeared before the Board.

Motion made by County Commissioner Duffy, second by Deputy Director James, that the public hearing be closed, which motion was carried on a roll call of five (5) votes in the affirmative with County Commissioners Akhter and Bartlett being absent.

Motion made by Deputy Director James, second by County Commissioner Duffy, that Bond Ordinance #2021-05 under consideration at this time be adopted upon final reading, and that the Clerk of the Board be directed to publish said ordinance in full, as required by the law in the North Jersey Herald & News which motion was carried on roll call with five (5) votes in the affirmative with County Commissioners Akhter and Bartlett being absent.

Motion made by Deputy Director James, second by County Commissioner Duffy, to resume the regular order of business, which motion was carried on a roll call of five (5) votes in the affirmative with County Commissioners Akhter and Bartlett being absent.

At this time Director Lepore asked if there were any County Commissioner Reports.

1. County Commissioner Director Pasquale "Pat" Lepore
2. County Commissioner Deputy Director Bruce James
3. County Commissioner Assad R. Akhter
4. County Commissioner John W. Bartlett
5. County Commissioner Theodore O. Best, Jr.
6. County Commissioner Terry Duffy
7. County Commissioner Cassandra "Sandi" Lazzara

**COMMUNICATION: None**

**ORAL PORTION:**

Lazzara: Motion to open the public portion.  
Duffy: Second.

ROLL CALL: Akhter, Absent: Bartlett, Absent: Best, Yes: Duffy, Yes: James,  
Yes: Lazzara, Yes: Director Lepore, Yes:

At this time there was two emails that came in.

1. Renee Alessio, West Milford
2. Margret Wood, West Milford

James: Motion to close the Public Portion of the Meeting.  
Duffy: Second

ROLL CALL: Akhter, Absent: Bartlett, Absent: Best, Yes: Duffy, Yes: James,  
Yes: Lazzara, Yes: Director Lepore, Yes:

**Consent Agenda Resolutions:**

A motion was made by Deputy Director James, second by County Commissioner Duffy to amend Resolution O-31 and O-70 and the motion was carried on a roll call with five (5) votes in the affirmative with County Commissioner Akhter and Bartlett being absent.

A motion was made by Deputy Director James, seconded by County Commissioner Duffy that Resolutions O-1 through O-84 with the amendments be adopted, and the motion was carried on roll call with five (5) votes in the affirmative with County Commissioners Akhter and Bartlett being absent.

**"End of Consent Agenda"**

**New Business:****Personnel:**

A motion was made by Deputy Director James, Second by County Commissioner Lazzara, that all Personnel matters be approved that were submitted by the Office of Human Resources. Then the Office of Human Resources shall be directed to notify the County Finance Department and New Jersey Department of Personnel accordingly, which motion was approved, with five (5) votes in the affirmative with County Commissioner Akhter and Bartlett being absent.

**Bills:**

Motion made by Deputy Director James, seconded by County Commissioner Lazzara, that

Current Fund	0-01	378,114.81
Current Fund	1-01	8,046,105.22
HUD Budget Expenditures	1-25	<u>22,500.75</u>
	<b>Year Total:</b>	<b>8,068,605.97</b>
General Capital Fund Budget	C-04	1,596,975.12
State/Federal Grant Fund	G-01	7,531,642.67
Open Space Trust	O-16	857.34
Open Space Trust	O-19	2,812.50
Open Space Trust	O-20	17,053.00
Open Space Trust	O-21	<u>28,570.09</u>
	<b>Year Total:</b>	<b>49,292.93</b>
Register of Deeds Trust	T-17	342.16
Professional Liability Trust	T-19	259,120.28
Trust Fund Other	T-20	28,709.03
Municipal Forfeiture Fund	T-22	37,500.00
Prosecutor's Confiscated Funds	T-23	691,878.56
Para Transit Trust	T-24	<u>1,020.00</u>
	<b>Year Total:</b>	<b>1,018,570.03</b>
Private Industry Council	Z-81	9,108.35
	<b>Total of All Funds</b>	<b>\$18,652,309.88</b>
Current Fund	0-01	17,300.27
Current Fund	1-01	22,738,559.92
Payroll Agency Deductions	1-05	5,237,968.75
HUD Budget	1-25	25,953.95
General Capital Fund Budget	C-04	42,150.27
State/Federal Grant Fund	G-01	894,045.82
Confiscated Trust Fund	T-15	1,872.00
Professional Liability Trust	T-19	7,712.50
Trust Fund Other	T-20	10,913.23
Para Transit Trust Fund	T-24	450.70
Private Industry Council	Z-81	20,207.30
	<b>Total All Funds:</b>	<b>\$28,997,134.71</b>

Be approved which motion was carried on roll call with five (5) votes in the affirmative with County Commissioner Akhter and Bartlett being absent.

Adjournment

Motion made by Deputy Director James, seconded by County Commissioner Lazzara that the regular meeting be adjourned at 6:34 p.m., and the motion was carried on roll call with five (5) votes in the affirmative with County Commissioner Akhter and Bartlett being absent.

(The proceedings of this meeting were both audio and video taped recorded)

Respectfully Submitted,

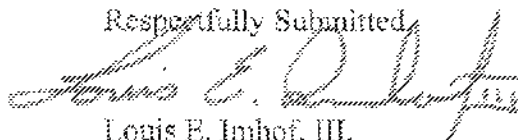

Louis E. Imhof, III,  
Clerk of the Board

Prepared by: Andrea Lisa McDowell

Hill, Lisa

---

**From:** LJ Koch <lucsfajitahut@gmail.com>  
**Sent:** Tuesday, July 20, 2021 1:44 PM  
**To:** Hill, Lisa  
**Subject:** Letter for road closure 9/11 tribute & memorial

Caution! This message was sent from outside of Passaic County. This may be normal, we just wanted you to be aware.

[Allow sender](#) | [Block sender](#)

Good Afternoon Mrs. Hill,

Thank you for your time on the phone. As requested please let this email serve as my letter in which can be forwarded to the engineering department, and county board agenda.

The address of my restaurant is where the main event is taking place. it is 1934 Greenwood Lake Tpke, Hewitt (West Milford) NJ, 07421. We are looking to have the road closure and detour set up from the corner of Lincoln ave (local traffic only) and greenwood lake tpke, to browns point which is about the stretch of 3/4 of a mile. There are multiple detour routes possible via Tintle Ave, or Lincoln ave to Union Valley road, past shoprite.

My company will be hosting the event, The Fajita Hut, LLC. Doing business as Luc's Fajita Hut. the event date is September 11th, 2021. we need the closure from 2pm - 10pm. We have about 20 local business getting involved with this event. The event will consist of live music, moment of silence, a singing of the national anthem, food trucks, and car show. Local business will be supporting with their trucks hanging american flags off of them, etc.

Please let me know asap if you need any other information from me.

Thank you !

--  
LJ Koch, Chef / Owner  
Luc's Fajita Hut  
973.800.0765

Introduced on: August 10, 2021  
Adopted on:  
Official Resolution#:



# County of Passaic Board of County Commissioners

OFFICE OF COUNTY COMMISSIONERS

Director Pasquale "Pat" Lepore  
Deputy Director Bruce James  
Assad R. Akhter  
John W. Bartlett  
Theodore O. Best, Jr.  
Terry Duffy  
Cassandra "Sandi" Lazzara

401 Grand Street  
Paterson, New Jersey 07505  
Tel: 973-881-4402  
Fax: 973-742-3746

Anthony J. De Nova III  
*Administrator*  
Matthew P. Jordan, Esq.  
*County Counsel*  
Louis E. Imhof, III, RMC  
*Clerk Of The Board*



## Public Meeting (Board Meeting)

Date: Aug 10, 2021 - 5:30 PM

Location: County Administration Building  
Webex - 220  
401 Grand Street  
Paterson, NJ 07505

Agenda: REQUESTING APPROVAL FOR THE INSERTION OF A SPECIAL ITEM OF REVENUE IN THE 2021 BUDGET PURSUANT TO N.J.S. 40A:4- 87 (Chapter 159 P.L. 148) CDBGCV3, ALL AS NOTED IN THE RESOLUTION.

THIS RESOLUTION WAS REQUESTED BY:

FINANCE DEPARTMENT

REVIEWED BY:

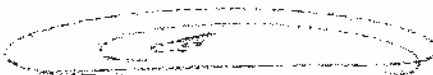
  
Anthony J. De Nova III

COUNTY ADMINISTRATOR

APPROVED AS TO FORM AND LEGALITY:

  
Matthew P. Jordan, Esq.

COUNTY COUNSEL

Administration and Finance

COMMITTEE NAME

<b>Official Resolution#</b>	<b>R20210717</b>							
Meeting Date	08/10/2021							
Introduced Date	08/10/2021							
Adopted Date	08/10/2021							
Agenda Item	I-1							
CAF #								
Purchase Req. #								
Result	Adopted							
<b>COMMISSIONER</b>	<b>PRES.</b>	<b>ABS.</b>	<b>MOVE</b>	<b>SEC</b>	<b>AYE</b>	<b>NAY</b>	<b>ABST.</b>	<b>RECU.</b>
Lepore	✓				✓			
James	✓		✓		✓			
Akhter	✓			✓	✓			
Bartlett	✓				✓			
Best Jr.	✓				✓			
Duffy	✓				✓			
Lazzara	✓				✓			

PRES.= present ABS.= absent  
 MOVE= moved SEC= seconded  
 AYE= yes NAY= no ABST.= abstain  
 RECU.= recuse

Dated: August 11, 2021

**RESOLUTION AUTHORIZING THE CHIEF FINANCIAL OFFICER TO  
REQUEST APPROVAL OF ITEMS OF REVENUE AND APPROPRIATION  
PURSUANT TO NJS 40A:4-87 (Chapter 159 P.L. 158)**

WHEREAS, N.J.S. 40A:4-87 provides that the Director of the Division of Local Government Services may approve the insertion of any special item of revenue in the Budget of any County or Municipality when such item shall have been made available by law and the amount thereof was not determined at the time of the adoption of the Budget, and

WHEREAS the County is desirous at this time to anticipate and appropriate a sum of \$881,057.00 for the aforementioned program, and

NOW, THEREFORE, BE IT FURTHER RESOLVED, that the County of Passaic hereby requests the Director of the Division of Local Government Services to approve the insertion of an additional item of revenue in the budget for the year 2021

In the sum of \$881,057.00

Which item is now available as revenue from a grant award from the U.S. Department of Housing and Urban Development, Community Planning & Development, Community Development Block Grant (CDBGCV3) [B-20-UW-34-0112]

**SECTION II.**

BE IT FURTHER RESOLVED that a like sum of \$881,057.00 be and the same is hereby appropriated under the caption U.S. Department of Housing and Urban Development, Community Planning & Development, Community Development Block Grant (CDBGCV3) [B-20-UW-34-0112]

BE IT FURTHER RESOLVED that an electronic copy of this resolution be forwarded to the Division of Local Government Services.

This resolution was requested by:  
Richard Cahill  
CHIEF FINANCIAL OFFICER

# County of Passaic Board of County Commissioners

OFFICE OF COUNTY COMMISSIONERS

Director Pasquale "Pat" Lepore  
Deputy Director Bruce James  
Assad R. Akhter  
John W. Bartlett  
Theodore O. Best, Jr.  
Terry Duffy  
Cassandra "Sandi" Lazzara

401 Grand Street  
Paterson, New Jersey 07505

Tel: 973-881-4402  
Fax: 973-742-3746

Anthony J. De Nova III  
Administrator

Matthew P. Jordan, Esq.  
County Counsel

Louis E. Imhof, III, RMC  
Clerk Of The Board



## Public Meeting (Board Meeting)

Date: Aug 10, 2021 - 5:30 PM

Location: County Administration Building  
Webex - 220  
401 Grand Street  
Paterson, NJ 07505

Agenda: REQUESTING APPROVAL FOR THE INSERTION OF A SPECIAL ITEM OF REVENUE IN THE 2021 BUDGET PURSUANT TO N.J.S. 40A:4- 87 (Chapter 159 P.L. 148) CDBG-COVID-19 CV2, ALL AS NOTED IN THE RESOLUTION.

THIS RESOLUTION WAS REQUESTED BY:

FINANCE DEPARTMENT

REVIEWED BY:

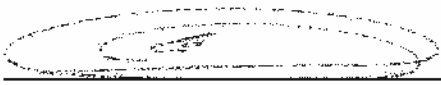
  
Anthony J. De Nova III

COUNTY ADMINISTRATOR

APPROVED AS TO FORM AND LEGALITY:

  
Matthew P. Jordan, Esq.

COUNTY COUNSEL

Administration and Finance

COMMITTEE NAME

<b>Official Resolution#</b>	<b>R20210718</b>							
Meeting Date	08/10/2021							
Introduced Date	08/10/2021							
Adopted Date	08/10/2021							
Agenda Item	I-2							
CAF #								
Purchase Req. #								
Result	Adopted							
<b>COMMISSIONER</b>	<b>PRES.</b>	<b>ABS.</b>	<b>MOVE</b>	<b>SEC</b>	<b>AYE</b>	<b>NAY</b>	<b>ABST.</b>	<b>RECU.</b>
Lepore	✓				✓			
James	✓		✓		✓			
Akhter	✓			✓	✓			
Bartlett	✓				✓			
Best Jr.	✓				✓			
Duffy	✓				✓			
Lazzara	✓				✓			

PRES.= present ABS.= absent  
MOVE= moved SEC= seconded  
AYE= yes NAY= no ABST.= abstain  
RECU.= recuse

Dated: August 11, 2021

**RESOLUTION AUTHORIZING THE CHIEF FINANCIAL OFFICER TO  
REQUEST APPROVAL OF ITEMS OF REVENUE AND APPROPRIATION  
PURSUANT TO NJS 40A:4-87 (Chapter 159 P.L. 158)**

WHEREAS N.J.S. 40A:4-87 provides that the Director of the Division of Local Government Services may approve the insertion of any special item of revenue in the Budget of any County or Municipality when such item shall have been made available by law and the amount thereof was not determined at the time of the adoption of the Budget, and

WHEREAS the County is desirous at this time to anticipate and appropriate a sum of \$2,287,345.00 for the aforementioned program, and

NOW, THEREFORE, BE IT FURTHER RESOLVED, that the County of Passaic hereby requests the Director of the Division of Local Government Services to approve the insertion of an additional item of revenue in the budget for the year 2021

In the sum of \$2,287,345.00

Which item is now available as revenue from a grant award from the State of New Jersey, Department of Community Affairs, CDBG-COVID-19 CV2 2020 [2020-02302-0496-00]

**SECTION II.**

BE IT FURTHER RESOLVED that a like sum of \$2,287,345.00 be and the same is hereby appropriated under the caption State of New Jersey, Department of Community Affairs, CDBG-COVID-19 CV2 2020 [2020-02302-0496-00]

BE IT FURTHER RESOLVED that an electronic copy of this resolution be forwarded to the Division of Local Government Services.

This resolution was requested by:  
Richard Cahill  
CHIEF FINANCIAL OFFICER

# County of Passaic Board of County Commissioners

OFFICE OF COUNTY COMMISSIONERS

Director Pasquale "Pat" Lepore  
Deputy Director Bruce James  
Assad R. Akhter  
John W. Bartlett  
Theodore O. Best, Jr.  
Terry Duffy  
Cassandra "Sandi" Lazzara

401 Grand Street  
Paterson, New Jersey 07505

Tel: 973-881-4402  
Fax: 973-742-3746

Anthony J. De Nova III  
Administrator

Matthew P. Jordan, Esq.  
County Counsel

Louis E. Imhof, III, RMC  
Clerk Of The Board



## Public Meeting (Board Meeting)

Date: Aug 10, 2021 - 5:30 PM

Location: County Administration Building  
Webex - 220  
401 Grand Street  
Paterson, NJ 07505

Agenda: REQUESTING APPROVAL FOR THE INSERTION OF A SPECIAL ITEM OF REVENUE IN THE 2021 BUDGET PURSUANT TO N.J.S. 40A:4- 87 (Chapter 159 P.L. 148) LBF- High Mtn Rd Culvert, ALL AS NOTED IN THE RESOLUTION.

THIS RESOLUTION WAS REQUESTED BY:

FINANCE DEPARTMENT

REVIEWED BY:

Anthony J. De Nova III

COUNTY ADMINISTRATOR

APPROVED AS TO FORM AND LEGALITY:

Matthew P. Jordan, Esq.

COUNTY COUNSEL

Administration and Finance

COMMITTEE NAME

<b>Official Resolution#</b>	<b>R20210719</b>							
Meeting Date	08/10/2021							
Introduced Date	08/10/2021							
Adopted Date	08/10/2021							
Agenda Item	I-3							
CAF #								
Purchase Req. #								
Result	Adopted							
<b>COMMISSIONER</b>	<b>PRES.</b>	<b>ABS.</b>	<b>MOVE</b>	<b>SEC</b>	<b>AYE</b>	<b>NAY</b>	<b>ABST.</b>	<b>RECU.</b>
Lepore	✓				✓			
James	✓		✓		✓			
Akhter	✓			✓	✓			
Bartlett	✓				✓			
Best Jr.	✓				✓			
Duffy	✓				✓			
Lazzara	✓				✓			

PRES.= present ABS.= absent  
 MOVE= moved SEC= seconded  
 AYE= yes NAY= no ABST.= abstain  
 RECU.= recuse

Dated: August 11, 2021

**RESOLUTION AUTHORIZING THE CHIEF FINANCIAL OFFICER TO  
REQUEST APPROVAL OF ITEMS OF REVENUE AND APPROPRIATION  
PURSUANT TO NJS 40A:4-87 (Chapter 159 P.L. 158)**

WHEREAS N.J.S. 40A:4-87 provides that the Director of the Division of Local Government Services may approve the insertion of any special item of revenue in the Budget of any County or Municipality when such item shall have been made available by law and the amount thereof was not determined at the time of the adoption of the Budget, and

WHEREAS the County is desirous at this time to anticipate and appropriate a sum of \$1,300,000.00 for the program noted below, and

NOW, THEREFORE, BE IT FURTHER RESOLVED, that the County of Passaic hereby requests the Director of the Division of Local Government Services to approve the insertion of an additional item of revenue in the budget for the year 2021

In the sum of \$1,300,000.00

Which item is now available as revenue from a grant award from the State of New Jersey, Department of Transportation, 2021 NJDOT Local Bridge Fund - High Mtn Rd Culvert [1600-338/00038]

**SECTION II.**

BE IT FURTHER RESOLVED that a like sum of \$1,300,000.00 be and the same is hereby appropriated under the caption the State of New Jersey, Department of Transportation, 2021 NJDOT Local Bridge Fund - High Mtn Rd Culvert [1600-338/00038]

BE IT FURTHER RESOLVED that an electronic copy of this resolution be forwarded to the Division of Local Government Services.

This resolution was requested by:  
Richard Cahill  
CHIEF FINANCIAL OFFICER

# County of Passaic Board of County Commissioners

OFFICE OF COUNTY COMMISSIONERS

Director Pasquale "Pat" Lepore  
Deputy Director Bruce James  
Assad R. Akhter  
John W. Bartlett  
Theodore O. Best, Jr.  
Terry Duffy  
Cassandra "Sandi" Lazzara

401 Grand Street  
Paterson, New Jersey 07505  
Tel: 973-881-4402  
Fax: 973-742-3746

Anthony J. De Nova III  
*Administrator*  
Matthew P. Jordan, Esq.  
*County Counsel*  
Louis E. Imhof, III, RMC  
*Clerk Of The Board*



## Public Meeting (Board Meeting)

Date: Aug 10, 2021 - 5:30 PM

Location: County Administration Building  
Webex - 220  
401 Grand Street  
Paterson, NJ 07505

Agenda: REQUESTING APPROVAL FOR THE INSERTION OF A SPECIAL ITEM OF REVENUE IN THE 2021 BUDGET PURSUANT TO N.J.S. 40A:4- 87 (Chapter 159 P.L. 148) LBF- Pennington Avenue, ALL AS NOTED IN THE RESOLUTION.

THIS RESOLUTION WAS REQUESTED BY:

FINANCE DEPARTMENT

REVIEWED BY:

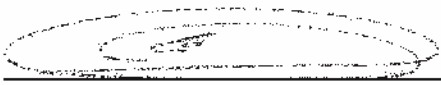
  
Anthony J. De Nova III

COUNTY ADMINISTRATOR

APPROVED AS TO FORM AND LEGALITY:

  
Matthew P. Jordan, Esq.

COUNTY COUNSEL

Administration and Finance

COMMITTEE NAME

<b>Official Resolution#</b>	<b>R20210720</b>							
Meeting Date	08/10/2021							
Introduced Date	08/10/2021							
Adopted Date	08/10/2021							
Agenda Item	I-4							
CAF #								
Purchase Req. #								
Result	Adopted							
<b>COMMISSIONER</b>	<b>PRES.</b>	<b>ABS.</b>	<b>MOVE</b>	<b>SEC</b>	<b>AYE</b>	<b>NAY</b>	<b>ABST.</b>	<b>RECU.</b>
Lepore	✓				✓			
James	✓		✓		✓			
Akhter	✓			✓	✓			
Bartlett	✓				✓			
Best Jr.	✓				✓			
Duffy	✓				✓			
Lazzara	✓				✓			

PRES.= present ABS.= absent  
MOVE= moved SEC= seconded  
AYE= yes NAY= no ABST.= abstain  
RECU.= recuse

Dated: August 11, 2021

**RESOLUTION AUTHORIZING THE CHIEF FINANCIAL OFFICER TO  
REQUEST APPROVAL OF ITEMS OF REVENUE AND APPROPRIATION  
PURSUANT TO NJS 40A:4-87 (Chapter 159 P.L. 158)**

WHEREAS N.J.S. 40A:4-87 provides that the Director of the Division of Local Government Services may approve the insertion of any special item of revenue in the Budget of any County or Municipality when such item shall have been made available by law and the amount thereof was not determined at the time of the adoption of the Budget, and

WHEREAS the County is desirous at this time to anticipate and appropriate a sum of \$900,000.00 for the program noted below, and

NOW, THEREFORE, BE IT FURTHER RESOLVED, that the County of Passaic hereby requests the Director of the Division of Local Government Services to approve the insertion of an additional item of revenue in the budget for the year 2021

In the sum of \$900,000.00

Which item is now available as revenue from a grant award from the State of New Jersey, Department of Transportation, 2021 NJDOT Local Bridge Fund - Pennington Avenue [1600-518/00039]

**SECTION II.**

BE IT FURTHER RESOLVED that a like sum of \$900,000.00 be and the same is hereby appropriated under the caption the State of New Jersey, Department of Transportation, 2021 NJDOT Local Bridge Fund - Pennington Avenue [1600-518/00039]

BE IT FURTHER RESOLVED that an electronic copy of this resolution be forwarded to the Division of Local Government Services.

This resolution was requested by:  
Richard Cahill  
CHIEF FINANCIAL OFFICER



# County of Passaic Board of County Commissioners

OFFICE OF COUNTY COMMISSIONERS

Director Pasquale "Pat" Lepore  
Deputy Director Bruce James  
Assad R. Akhter  
John W. Bartlett  
Theodore O. Best, Jr.  
Terry Duffy  
Cassandra "Sandi" Lazzara

401 Grand Street  
Paterson, New Jersey 07505  
Tel: 973-881-4402  
Fax: 973-742-3746

Anthony J. De Nova III  
*Administrator*  
Matthew P. Jordan, Esq.  
*County Counsel*  
Louis E. Imhof, III, RMC  
*Clerk Of The Board*



## Public Meeting (Board Meeting)

Date: Aug 10, 2021 - 5:30 PM

Location: County Administration Building  
Webex - 220  
401 Grand Street  
Paterson, NJ 07505

Agenda: REQUESTING APPROVAL FOR THE INSERTION OF A SPECIAL ITEM OF REVENUE IN THE 2021 BUDGET PURSUANT TO N.J.S. 40A:4- 87 (Chapter 159 P.L. 148) LBF- Passaic Ave Culvert, ALL AS NOTED IN THE RESOLUTION.

THIS RESOLUTION WAS REQUESTED BY:

FINANCE DEPARTMENT

REVIEWED BY:

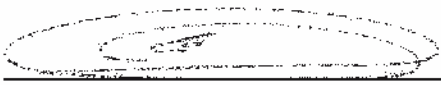
  
Anthony J. De Nova III

COUNTY ADMINISTRATOR

APPROVED AS TO FORM AND LEGALITY:

  
Matthew P. Jordan, Esq.

COUNTY COUNSEL

Administration and Finance

COMMITTEE NAME

<b>Official Resolution#</b>	<b>R20210721</b>							
Meeting Date	08/10/2021							
Introduced Date	08/10/2021							
Adopted Date	08/10/2021							
Agenda Item	I-5							
CAF #								
Purchase Req. #								
Result	Adopted							
<b>COMMISSIONER</b>	<b>PRES.</b>	<b>ABS.</b>	<b>MOVE</b>	<b>SEC</b>	<b>AYE</b>	<b>NAY</b>	<b>ABST.</b>	<b>RECU.</b>
Lepore	✓				✓			
James	✓		✓		✓			
Akhter	✓			✓	✓			
Bartlett	✓				✓			
Best Jr.	✓				✓			
Duffy	✓				✓			
Lazzara	✓				✓			

PRES.= present ABS.= absent  
MOVE= moved SEC= seconded  
AYE= yes NAY= no ABST.= abstain  
RECU.= recuse

Dated: August 11, 2021

**RESOLUTION AUTHORIZING THE CHIEF FINANCIAL OFFICER TO  
REQUEST APPROVAL OF ITEMS OF REVENUE AND APPROPRIATION  
PURSUANT TO NJS 40A:4-87 (Chapter 159 P.L. 158)**

WHEREAS N.J.S. 40A:4-87 provides that the Director of the Division of Local Government Services may approve the insertion of any special item of revenue in the Budget of any County or Municipality when such item shall have been made available by law and the amount thereof was not determined at the time of the adoption of the Budget, and

WHEREAS the County is desirous at this time to anticipate and appropriate a sum of \$620,465.00 for the program noted below, and

NOW, THEREFORE, BE IT FURTHER RESOLVED, that the County of Passaic hereby requests the Director of the Division of Local Government Services to approve the insertion of an additional item of revenue in the budget for the year 2021

In the sum of \$620,465.00

Which item is now available as revenue from a grant award from the State of New Jersey, Department of Transportation, 2021 NJDOT Local Bridge Fund - Passaic Ave Culvert [1600-092/00040]

**SECTION II.**

BE IT FURTHER RESOLVED that a like sum of \$620,465.00 be and the same is hereby appropriated under the caption the State of New Jersey, Department of Transportation, 2021 NJDOT Local Bridge Fund - Passaic Ave Culvert [1600-092/00040]

BE IT FURTHER RESOLVED that an electronic copy of this resolution be forwarded to the Division of Local Government Services.

This resolution was requested by:  
Richard Cahill  
CHIEF FINANCIAL OFFICER

# County of Passaic Board of County Commissioners

OFFICE OF COUNTY COMMISSIONERS

Director Pasquale "Pat" Lepore  
Deputy Director Bruce James  
Assad R. Akhter  
John W. Bartlett  
Theodore O. Best, Jr.  
Terry Duffy  
Cassandra "Sandi" Lazzara

401 Grand Street  
Paterson, New Jersey 07505

Tel: 973-881-4402  
Fax: 973-742-3746

Anthony J. De Nova III  
Administrator

Matthew P. Jordan, Esq.  
County Counsel

Louis E. Imhof, III, RMC  
Clerk Of The Board



## Public Meeting (Board Meeting)

Date: Aug 10, 2021 - 5:30 PM

Location: County Administration Building  
Webex - 220  
401 Grand Street  
Paterson, NJ 07505

Agenda: RESOLUTION CANCELING UNEXPENDED BALANCES OF ANTICIPATED REVENUE AND APPROPRIATIONS MADE IN THE GRANTFUND, ALL AS NOTED IN THE RESOLUTION

THIS RESOLUTION WAS REQUESTED BY:

FINANCE DEPARTMENT

REVIEWED BY:

Anthony J. De Nova III

COUNTY ADMINISTRATOR

APPROVED AS TO FORM AND LEGALITY:

Matthew P. Jordan, Esq.

COUNTY COUNSEL

Administration and Finance

COMMITTEE NAME

<b>Official Resolution#</b>	<b>R20210722</b>							
Meeting Date	08/10/2021							
Introduced Date	08/10/2021							
Adopted Date	08/10/2021							
Agenda Item	I-6							
CAF #								
Purchase Req. #								
Result	Adopted							
<b>COMMISSIONER</b>	<b>PRES.</b>	<b>ABS.</b>	<b>MOVE</b>	<b>SEC</b>	<b>AYE</b>	<b>NAY</b>	<b>ABST.</b>	<b>RECU.</b>
Lepore	✓				✓			
James	✓		✓		✓			
Akhter	✓			✓	✓			
Bartlett	✓				✓			
Best Jr.	✓				✓			
Duffy	✓				✓			
Lazzara	✓				✓			

PRES.= present ABS.= absent  
MOVE= moved SEC= seconded  
AYE= yes NAY= no ABST.= abstain  
RECU.= recuse

Dated: August 11, 2021

**RESOLUTION CANCELING UNEXPENDED BALANCES OF ANTICIPATED REVENUE AND APPROPRIATIONS MADE IN THE GRANT FUND**

**WHEREAS** the County of Passaic (the “County”) is a government body incorporated pursuant to N.J.S.A. 40:18-1, et seq. and vested with all rights contained therein; and

**WHEREAS**, pursuant to N.J.S.A. 40:20-1 the Board of Commissioners for the County of Passaic (hereinafter the “Board”) are vested with decision making powers on behalf of the County; and

**WHEREAS**, pursuant to N.J.S.A. 40A:4-60 any unexpended balances of revenue and appropriations, by resolution of the Board, may be canceled prior to the end of the fiscal year; and

**WHEREAS**, after a review by the Chief Financial Officer of the grant balances which are old and will not be realized. The following Anticipated Revenue and Appropriation’s for various State and Federal Grants of Prior Years can be cancelled because same is no longer needed for the purpose in which it was appropriated:

<u>Grant Name</u>	<u>Receivable</u>
WIOA ADULT 18/19	130,917.00
	<hr/>
	<u>130,917.00</u>

<u>Grant Name</u>	<u>Reserve</u>
WIOA ADULT 18/19	130,917.85
	<hr/>
	<u>130,917.85</u>

**NOW, THEREFORE, BE IT RESOLVED**, that the Chief Financial Officer and County Treasurer are authorized cancel the State and Federal Grants Anticipated Revenue and Appropriation’s.

# County of Passaic Board of County Commissioners

OFFICE OF COUNTY COMMISSIONERS

Director Pasquale "Pat" Lepore  
Deputy Director Bruce James  
Assad R. Akhter  
John W. Bartlett  
Theodore O. Best, Jr.  
Terry Duffy  
Cassandra "Sandi" Lazzara

401 Grand Street  
Paterson, New Jersey 07505  
Tel: 973-881-4402  
Fax: 973-742-3746

Anthony J. De Nova III  
*Administrator*  
Matthew P. Jordan, Esq.  
*County Counsel*  
Louis E. Imhof, III, RMC  
*Clerk Of The Board*



## Public Meeting (Board Meeting)

Date: Aug 10, 2021 - 5:30 PM

Location: County Administration Building  
Webex - 220  
401 Grand Street  
Paterson, NJ 07505

Agenda: RESOLUTION AUTHORIZING A SECOND CONTRACT MODIFICATION WITH NW FINANCIAL GROUP TO ADMINISTER CARES ACT FUNDING FOR THE COUNTY OF PASSAIC, PURSUANT TO N.J.A.C. 5:30-11.6, ET SEQ., ALL AS NOTED IN THE RESOLUTION.

THIS RESOLUTION WAS REQUESTED BY:

REVIEWED BY:

Anthony J. De Nova III  
COUNTY ADMINISTRATOR

APPROVED AS TO FORM AND LEGALITY:

Matthew P. Jordan, Esq.  
COUNTY COUNSEL

Administration and Finance  
COMMITTEE NAME

<b>Official Resolution#</b>	<b>R20210723</b>							
Meeting Date	08/10/2021							
Introduced Date	08/10/2021							
Adopted Date	08/10/2021							
Agenda Item	I-7							
CAF #	G-01-41-962-020-PE1							
Purchase Req. #								
Result	Adopted							
<b>COMMISSIONER</b>	<b>PRES.</b>	<b>ABS.</b>	<b>MOVE</b>	<b>SEC</b>	<b>AYE</b>	<b>NAY</b>	<b>ABST.</b>	<b>RECU.</b>
Lepore	✓				✓			
James	✓		✓		✓			
Akhter	✓			✓	✓			
Bartlett	✓				✓			
Best Jr.	✓				✓			
Duffy	✓				✓			
Lazzara	✓				✓			

PRES.= present ABS.= absent  
MOVE= moved SEC= seconded  
AYE= yes NAY= no ABST.= abstain  
RECU.= recuse

Dated: August 11, 2021

**RESOLUTION AUTHORIZING A SECOND CONTRACT MODIFICATION WITH NW FINANCIAL GROUP TO ADMINISTER CARES ACT FUNDING FOR THE COUNTY OF PASSAIC, PURSUANT TO N.J.A.C. 5:30-11.6, ET SEQ.**

**WHEREAS**, the County of Passaic (hereafter “County”) is a body politic and corporate pursuant to N.J.S.A. 40:18-1 and vested with all rights contained therein; and

**WHEREAS**, pursuant to N.J.S.A. 40:20-1 the Board of County Commissioners of the County of Passaic (hereafter “Board”) is vested with managing the property, finances, and affairs of the County; and

**WHEREAS**, Coronavirus disease 2019 (hereinafter “COVID-19”) is a contagious, and at times fatal respiratory disease caused by SARS-CoV-2 virus; and

**WHEREAS**, on March 9, 2020, New Jersey Governor Philip Murphy, in order to protect the health, safety, and welfare of the people of the State of New Jersey, signed Executive Order No. 103, declaring a Public Health Emergency and State of Emergency exist in the State of New Jersey; and

**WHEREAS**, on March 27, 2020, the Coronavirus Aid, Relief, and Economic Security Act, 2020 116 P.L. 136, 2020 Enacted H.R. 748, 116 Enacted H.R. 748, 134 Stat. 281, 116 P.L. 136, 2020 Enacted H.R. 748, 116 Enacted H.R. 748, 134 Stat. 281 (hereafter “CARES Act”); and

**WHEREAS**, the CARES Act established the Coronavirus Relief Fund (hereafter “Fund”) and appropriated \$150 billion, and is to be used to make payments for specified uses to States and certain local governments, the District of Columbia, and United States Territories, and Tribal governments; and

**WHEREAS**, the County was appropriated eighty seven million five hundred sixty four thousand seven hundred and sixty seven dollars and twenty cents (\$87,564,767.20) from the Fund, to be used for expenditures incurred due to the public health emergency with respect to COVID-19, were not accounted for in the budget most recently approved as of March 27, 2020, and were incurred during the period that begins March 1, 2020 and ends on December 30, 2020; and

**WHEREAS**, in compliance with guidance from the United States Treasury Department, the Board authorized reimbursable grant awards to the sixteen (16) municipalities in Passaic County, to be used for expenses related to the Public Health Emergency and mitigating the spread of COVID-19; and

**WHEREAS**, pursuant to N.J.S.A. 40A:11-5, et seq. the County issued RFQ-20-069, seeking qualifications for a pool of financial advisor services firms (hereafter “RFQ-20-069”) to, among other listed services, administer the CARES Act reimbursement applications submitted by the municipalities; and

**WHEREAS**, pursuant to N.J.S.A. 19:44A-20.4, the County’s request for qualifications is a fair and open process, specifically, the qualification for the pool of financial advisor services firms is publicly advertised, awarded under a process that provides for public solicitation of qualifications, established the basis of an award and disclosure process documented in writing prior to any solicitation, and is publicly opened and announced when awarded; and

**WHEREAS**, on June 16, 2020 the Board approved Resolution No. R20200449 qualifying a pool of financial advisor firms, as recommended by the Chief Financial Officer, which included NW Financial Group and awarded a one hundred thousand dollar (\$100,000.00) contract to NW Financial Group to administer CARES Act reimbursement applications submitted by the municipalities on behalf of the County;

**WHEREAS**, pursuant to N.J.A.C. 5:30-11.6, the County can authorize contract modifications for professional services and extraordinary unspecifiable services, when the change is within the scope of activities of the original contract, and not for the purpose of undertaking new or different work or projects; and

**WHEREAS**, on December 8, 2020 the Board approved Resolution No. R20201066 authorizing a contract modification with NW Financial Group for the services as outlined herein; and

**WHEREAS**, the Chief Financial Officer is recommending that the appropriation for NW Financial Group be increased in an amount not to exceed forty thousand dollars (\$40,000.00) to continue its work administering CARES Act reimbursement applications submitted by the municipalities; and

**WHEREAS**, funds are available in Account No. G-0141-962-020-PE1, or any other account that may be deemed appropriate by the Chief Financial Officer or his designee, and the availability of funds has been contingently certified by the Chief Financial Officer subject to sufficient funds being appropriated by the Board in the 2021 and/or subsequent years' County budget(s), which is attached to and made part of this Resolution; and

**WHEREAS**, this matter was discussed at the July 27, 2021 meeting of the Administration and Finance Committee, and is being recommended to the Board for approval; and

**NOW, THEREFORE, LET IT BE RESOLVED**, pursuant to N.J.A.C. 5:30-11.6 that the Board of County Commissioners of the County of Passaic is authorizing the second contract modification with NW Financial Group increasing the appropriation for NW Financial Group in an amount not to exceed forty thousand dollars (\$40,000.00) to continue its work administering CARES Act reimbursement applications submitted by the municipalities.

**LET IT BE FURTHER RESOLVED**, the Clerk of the Board shall print, in the official newspaper, a brief notice stating the nature, duration, service, and amount of the contract modification to NW Financial Group and maintain a copy of the Resolution on file and available for public inspection in the Office of the Clerk of the Board.

**LET IT BE FURTHER RESOLVED**, that the Clerk of the Board, County Counsel, and the Director of the Board of County Commissioners are authorized to take any other steps necessary to carry out the purpose of this Resolution.

MPJ

August 10, 2021

CERTIFICATION OF AVAILABLE FUNDS

THIS IS TO CERTIFY THAT FUNDS ARE AVAILABLE AS FOLLOWS:

AMOUNT: \$40,000.00

APPROPRIATION: G-01-41-962-020-PE1

PURPOSE: Authorizing a second contract modification with NW Financial Group to administer CARES Act Funding for the County.

  
Richard Cahill, Director of Finance

DATED: August 10, 2021



# County of Passaic Board of County Commissioners

OFFICE OF COUNTY COMMISSIONERS

Director Pasquale "Pat" Lepore  
Deputy Director Bruce James  
Assad R. Akhter  
John W. Bartlett  
Theodore O. Best, Jr.  
Terry Duffy  
Cassandra "Sandi" Lazzara

401 Grand Street  
Paterson, New Jersey 07505

Tel: 973-881-4402  
Fax: 973-742-3746

Anthony J. De Nova III  
Administrator

Matthew P. Jordan, Esq.  
County Counsel

Louis E. Imhof, III, RMC  
Clerk Of The Board



## Public Meeting (Board Meeting)

Date: Aug 10, 2021 - 5:30 PM

Location: County Administration Building  
Webex - 220  
401 Grand Street  
Paterson, NJ 07505

Agenda: RESOLUTION AMENDING THE REGULAR MEETING SCHEDULE FOR THE BOARD OF COUNTY COMMISSIONERS FOR CALENDAR YEAR 2021, PURSUANT TO N.J.S.A. 10:4-18, ALL AS NOTED IN THE RESOLUTION.

THIS RESOLUTION WAS REQUESTED BY:

COUNTY ADMINISTRATOR

REVIEWED BY:

  
Anthony J. De Nova III

COUNTY ADMINISTRATOR

APPROVED AS TO FORM AND LEGALITY:

  
Matthew P. Jordan, Esq.

COUNTY COUNSEL

Administration and Finance

COMMITTEE NAME

<b>Official Resolution#</b>	<b>R20210724</b>							
Meeting Date	08/10/2021							
Introduced Date	08/10/2021							
Adopted Date	08/10/2021							
Agenda Item	I-8							
CAF #								
Purchase Req. #								
Result	Adopted							
<b>COMMISSIONER</b>	<b>PRES.</b>	<b>ABS.</b>	<b>MOVE</b>	<b>SEC</b>	<b>AYE</b>	<b>NAY</b>	<b>ABST.</b>	<b>RECU.</b>
Lepore	✓				✓			
James	✓		✓		✓			
Akhter	✓			✓	✓			
Bartlett	✓				✓			
Best Jr.	✓				✓			
Duffy	✓				✓			
Lazzara	✓				✓			

PRES.= present ABS.= absent  
 MOVE= moved SEC= seconded  
 AYE= yes NAY= no ABST.= abstain  
 RECU.= recuse

Dated: August 11, 2021

**RESOLUTION AMENDING THE REGULAR MEETING SCHEDULE FOR THE BOARD OF COUNTY COMMISSIONERS FOR CALENDAR YEAR 2021, PURSUANT TO N.J.S.A. 10:4-18**

**WHEREAS**, the County of Passaic (hereafter “County”) is a body politic and corporate pursuant to N.J.S.A. 40:18-1 and vested with all rights contained therein; and

**WHEREAS**, pursuant to N.J.S.A. 40:20-1 the Board of County Commissioners for the County of Passaic (hereafter “Board”) is vested with managing the property, finances, and affairs of the County; and

**WHEREAS**, pursuant to N.J.S.A. 10:4-18, at least once a year, within seven days following the annual reorganization meeting of the Board, the Clerk of the Board shall post a schedule that contains the location, time, and date of each meeting of the Board for the calendar year; and

**WHEREAS**, on January 7, 2021 the Board approved Resolution No. 20210001 establishing the regular meeting schedule for the Board for calendar year 2021, pursuant to N.J.S.A. 10:4-18; and

**WHEREAS**, on May 26, 2021 the Board approved Resolution No. R20210494 amending the regular meeting scheduled for the Board; and

**WHEREAS**, on March 9, 2020, New Jersey Governor Philip Murphy, in order to protect the health, safety, and welfare of the people of the State of New Jersey, signed Executive Order No. 103, declaring a Public Health Emergency and State of Emergency exist in the State of New Jersey, and subsequent Executive Orders extending same; and

**WHEREAS**, after the declaration of the Public Health Emergency, the New Jersey Legislature adopted N.J.S.A. 10:4-9.3, allowing the Board to conduct public meetings during a state of emergency, public health emergency, or state of local disaster emergency by means of communication of electronic equipment; and

**WHEREAS**, Governor Murphy signed Assembly Bill No. 5820, allowing for the continuation of certain State agencies to modify and issue new emergency orders for certain purposes that can continue after the Public Health Emergency declared in Executive Order No. 103 is terminated to avoid disruption in New Jersey’s emergency response; and

**WHEREAS**, in light of this legislation becoming law, Governor Murphy signed Executive Order No. 244, that, among other items, lifted the Public Health Emergency in New Jersey, but left in place the State of Emergency declared in same pursuant to N.J.S.A. App. A.: 9-33, et seq., to allow for the continued management of New Jersey’s recovery and response to the COVID-19 pandemic; and

**WHEREAS**, the Board now desires to resume conducting public meetings in-person, and is going to amend the Regular Meeting Schedule pursuant to the schedule affixed hereto, which is incorporated and made part of this Resolution; and

**WHEREAS**, this matter was discussed at the July 27, 2021 meeting of the Administration and Finance Committee, and is being recommended to the Board for approval; and

**NOW, THEREFORE, LET IT BE RESOLVED**, pursuant to the N.J.S.A. 10:4-18 that the Board of County Commissioners for the County of Passaic adopts the amended calendar year 2021 meeting schedule affixed to and made part of this Resolution.

**LET IT BE FURTHER RESOLVED** that the Clerk of the Board, County Administrator, and County Counsel are authorized to take any steps necessary to carry out the purposes of this resolution and ensure compliance with N.J.S.A. 10:4-1, et seq.

MPJ

August 10, 2021

**Calendar Year 2021 Amended Regular Meeting Schedule  
Board of County Commissioners for the County of Passaic**

<b>DATE</b>	<b>TIME</b>	<b>LOCATION</b>
September 8, 2021	5:30 PM	300 Oldham Road, Wayne, New Jersey 07470
September 28, 2021	5:30 PM	401 Grand Street, Paterson, New Jersey 07505
October 26, 2021	5:30 PM	401 Grand Street, Paterson, New Jersey 07505
November 9, 2021	5:30 PM	401 Grand Street, Paterson, New Jersey 07505
November 23, 2021	5:30 PM	401 Grand Street, Paterson, New Jersey 07505
December 14, 2021	5:30 PM	401 Grand Street, Paterson, New Jersey 07505
December 28, 2021	5:30 PM	401 Grand Street, Paterson, New Jersey 07505

Meetings of the Board shall be conducted in-person in accordance with the provisions as set forth in N.J.S.A. 10:4-1, et seq. and the adopted By-Laws of the Board.

# County of Passaic Board of County Commissioners

OFFICE OF COUNTY COMMISSIONERS

Director Pasquale "Pat" Lepore  
Deputy Director Bruce James  
Assad R. Akhter  
John W. Bartlett  
Theodore O. Best, Jr.  
Terry Duffy  
Cassandra "Sandi" Lazzara

401 Grand Street  
Paterson, New Jersey 07505  
Tel: 973-881-4402  
Fax: 973-742-3746

Anthony J. De Nova III  
*Administrator*  
Matthew P. Jordan, Esq.  
*County Counsel*  
Louis E. Imhof, III, RMC  
*Clerk Of The Board*



## Public Meeting (Board Meeting)

Date: Aug 10, 2021 - 5:30 PM

Location: County Administration Building  
Webex - 220  
401 Grand Street  
Paterson, NJ 07505

Agenda: RESOLUTION AUTHORIZING A MEMORANDUM OF UNDERSTANDING WITH THE NEW JERSEY REENTRY CORPORATION, PURSUANT TO N.J.S.A. 40:20-1, ALL AS NOTED IN THE RESOLUTION.

THIS RESOLUTION WAS REQUESTED BY:

COUNTY ADMINISTRATOR

REVIEWED BY:

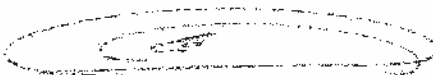
  
Anthony J. De Nova III

COUNTY ADMINISTRATOR

APPROVED AS TO FORM AND LEGALITY:

  
Matthew P. Jordan, Esq.

COUNTY COUNSEL

Administration and Finance

COMMITTEE NAME

<b>Official Resolution#</b>	<b>R20210725</b>							
Meeting Date	08/10/2021							
Introduced Date	08/10/2021							
Adopted Date	08/10/2021							
Agenda Item	I-9							
CAF #								
Purchase Req. #								
Result	Adopted							
<b>COMMISSIONER</b>	<b>PRES.</b>	<b>ABS.</b>	<b>MOVE</b>	<b>SEC</b>	<b>AYE</b>	<b>NAY</b>	<b>ABST.</b>	<b>RECU.</b>
Lepore	✓				✓			
James	✓		✓		✓			
Akhter	✓			✓	✓			
Bartlett	✓				✓			
Best Jr.	✓				✓			
Duffy	✓				✓			
Lazzara	✓				✓			

PRES.= present ABS.= absent  
MOVE= moved SEC= seconded  
AYE= yes NAY= no ABST.= abstain  
RECU.= recuse

Dated: August 11, 2021

**RESOLUTION AUTHORIZING A MEMORANDUM OF UNDERSTANDING WITH THE  
NEW JERSEY REENTRY CORPORATION, PURSUANT TO N.J.S.A. 40:20-1**

**WHEREAS**, the County of Passaic (hereafter “County”) is a body politic and corporate pursuant to N.J.S.A. 40:18-1 and vested with all rights contained therein; and

**WHEREAS**, pursuant to N.J.S.A. 40:20-1 the Board of County Commissioners for the County of Passaic (hereafter “Board”) is vested with managing the property, finances, and affairs of the County; and

**WHEREAS**, the Board desires to enter into a Memorandum of Understanding with the New Jersey Reentry Corporation to implement a reentry program for individuals who were formerly incarcerated and provide employment opportunities with the County; and

**WHEREAS**, this matter was discussed at the July 27, 2021 meeting of the Administration and Finance Committee, and is being recommended to the Board for approval; and

**NOW, THEREFORE, LET IT BE RESOLVED**, pursuant to the N.J.S.A. 40:20-1 that the Board of County Commissioners for the County of Passaic authorizes a Memorandum of Understanding with the New Jersey Reentry Corporation in a form and manner as prescribed by the County Counsel.

**LET IT BE FURTHER RESOLVED** that the Clerk of the Board, County Administrator, and County Counsel are authorized to take any steps necessary to carry out the purposes of this Resolution, including executing the Memorandum of Understanding.

MPJ

August 10, 2021

# County of Passaic Board of County Commissioners

OFFICE OF COUNTY COMMISSIONERS

Director Pasquale "Pat" Lepore  
Deputy Director Bruce James  
Assad R. Akhter  
John W. Bartlett  
Theodore O. Best, Jr.  
Terry Duffy  
Cassandra "Sandi" Lazzara

401 Grand Street  
Paterson, New Jersey 07505  
Tel: 973-881-4402  
Fax: 973-742-3746

Anthony J. De Nova III  
*Administrator*  
Matthew P. Jordan, Esq.  
*County Counsel*  
Louis E. Imhof, III, RMC  
*Clerk Of The Board*



## Public Meeting (Board Meeting)

Date: Aug 10, 2021 - 5:30 PM

Location: County Administration Building  
Webex - 220  
401 Grand Street  
Paterson, NJ 07505

Agenda: RESOLUTION RETAINING CLEARY GIACOBBE ALFIERI & JACOBS, LLC TO CONDUCT INTERNAL EMPLOYEE INVESTIGATIONS ON AN AS-NEEDED BASIS, PURSUANT TO N.J.S.A. 40A:11-5, ET SEQ., ALL AS NOTED IN THE RESOLUTION.

THIS RESOLUTION WAS REQUESTED BY:

COUNTY COUNSEL

REVIEWED BY:

Anthony J. De Nova III

COUNTY ADMINISTRATOR

APPROVED AS TO FORM AND LEGALITY:

Matthew P. Jordan, Esq.

COUNTY COUNSEL

Administration and Finance

COMMITTEE NAME

<b>Official Resolution#</b>	<b>R20210726</b>							
Meeting Date	08/10/2021							
Introduced Date	08/10/2021							
Adopted Date	08/10/2021							
Agenda Item	I-10							
CAF #	T-19-56-850-000-801							
Purchase Req. #	R1-13818							
Result	Adopted							
<b>COMMISSIONER</b>	<b>PRES.</b>	<b>ABS.</b>	<b>MOVE</b>	<b>SEC</b>	<b>AYE</b>	<b>NAY</b>	<b>ABST.</b>	<b>RECU.</b>
Lepore	✓				✓			
James	✓		✓		✓			
Akhter	✓			✓	✓			
Bartlett	✓				✓			
Best Jr.	✓				✓			
Duffy	✓				✓			
Lazzara	✓				✓			

PRES.= present ABS.= absent  
 MOVE= moved SEC= seconded  
 AYE= yes NAY= no ABST.= abstain  
 RECU.= recuse

Dated: August 11, 2021

**RESOLUTION RETAINING CLEARY GIACOBBE ALFIERI & JACOBS, LLC TO CONDUCT INTERNAL EMPLOYEE INVESTIGATIONS ON AN AS-NEEDED BASIS, PURSUANT TO N.J.S.A. 40A:11-5, ET SEQ.**

**WHEREAS**, the County of Passaic (hereafter “County”) is a body politic and corporate pursuant to N.J.S.A. 40:18-1 and vested with all rights contained therein; and

**WHEREAS**, pursuant to N.J.S.A. 40:20-1 the Board of County Commissioners of the County of Passaic (hereafter “Board”) is vested with managing the property, finances, and affairs of the County; and

**WHEREAS**, the County requires a law firm to conduct internal employee investigations on an as-needed basis; and

**WHEREAS**, pursuant to N.J.S.A. 40A:11-5, et seq. the County issued RFQ-21-002, Labor Counsel, Workplace Investigations, and Employment Trainings seeking qualifications for a pool of outside labor counsel for calendar year 2021, to be hired on an as-needed basis, to provide professional services to the County; and

**WHEREAS**, pursuant to N.J.S.A. 19:44A-20.4, the County’s request for qualifications is a fair and open process, specifically, the qualification for the pool of outside labor counsel for calendar year 2021 is publicly advertised, awarded under a process that provides for public solicitation of qualifications, established the basis of an award and disclosure process documented in writing prior to any solicitation, and is publicly opened and announced when awarded; and

**WHEREAS**, on November 16, 2020 the Board passed Resolution No. R20200944 qualifying a pool of outside labor counsel for calendar year 2021, as recommended by the County Counsel, to be hired on an as-needed basis, which included Cleary Giacobbe Alfieri & Jacobs, LLC; and

**WHEREAS**, the Passaic County Counsel is recommending to the Board to retain Cleary Giacobbe Alfieri & Jacobs, LLC for an amount not to exceed fifty thousand dollars (\$50,000.00), to conduct internal employee investigations on an as-needed basis; and

**WHEREAS**, funds are available in Account No. T-19-56-850-000-801, or any other account that may be deemed appropriate by the Chief Financial Officer or his designee, and the availability of funds has been contingently certified by the Chief Financial Officer subject to sufficient funds being appropriated by the Board in the 2021 and/or subsequent years’ County budget(s), which is attached to and made part of this Resolution; and

**WHEREAS**, this matter was discussed at the July 27, 2021 meeting of the Administration and Finance Committee and is being recommended to the Board for approval; and

**NOW, THEREFORE, LET IT BE RESOLVED**, pursuant to N.J.S.A. 40A:11-5(1)(a)(i) that the Board of County Commissioners of the County of Passaic is retaining Cleary Giacobbe Alfieri & Jacobs, LLC for an amount not to exceed fifty thousand dollars (\$50,000.00), to conduct internal employee investigations on an as-needed basis.

**LET IT BE FURTHER RESOLVED** the Clerk of the Board shall print, in the official newspaper, a brief notice stating the nature, duration, service, and amount of the contract to Cleary Giacobbe Alfieri & Jacobs, LLC and maintain a copy of the Resolution on file and available for public inspection in the Office of the Clerk to the Board.

**LET IT BE FURTHER RESOLVED** that the Clerk of the Board, County Counsel, and Director of the Board of County Commissioners are authorized to execute the contract and take any other steps necessary to carry out the purpose of this Resolution.

MPJ

August 10, 2021

COUNTY OF PASSAIC  
 INSURANCE DIV., CO OF PASSAIC  
 (Q) 973-881-4421  
 401 GRAND ST. ROOM 532  
 PATERSON, NJ 07505

REQUISITION	
NO.	R1-13818

SHIP TO	
VENDOR	VENDOR #: L1241 CLEARY GIACOBBE ALFIERI & JACOBS, LLC 955 STATE HIGHWAY 34 - STE 200 MATAWAN, NJ 07747-3106

ORDER DATE: 07/23/21  
 DELIVERY DATE:  
 STATE CONTRACT:  
 F.O.B. TERMS:

QTY/UNIT	DESCRIPTION	ACCOUNT NO.	UNIT PRICE	TOTAL COST
1.00	Outside counsel services For internal employee investigations.	T-19-56-850-000-801	50,000.0000	50,000.00
	DO NOT SEND PO TO VENDOR			
			TOTAL	50,000.00

Introduced on: August 10, 2021  
 Adopted on: August 10, 2021  
 Official Resolution#: R20210726

\_\_\_\_\_  
 REQUESTING DEPARTMENT DATE



CERTIFICATION OF AVAILABLE FUNDS

THIS IS TO CERTIFY THAT FUNDS ARE AVAILABLE AS FOLLOWS:

AMOUNT: \$50,000.00

APPROPRIATION: T-19-56-850-000-801

PURPOSE: Authorizing the retaining of Cleary Giacobbe Alfieri & Jacobs, LLC to conduct internal employee investigations on an as-needed basis.



Richard Cahill, Director of Finance

DATED: August 10, 2021

# County of Passaic Board of County Commissioners

OFFICE OF COUNTY COMMISSIONERS

Director Pasquale "Pat" Lepore  
Deputy Director Bruce James  
Assad R. Akhter  
John W. Bartlett  
Theodore O. Best, Jr.  
Terry Duffy  
Cassandra "Sandi" Lazzara

401 Grand Street  
Paterson, New Jersey 07505  
Tel: 973-881-4402  
Fax: 973-742-3746

Anthony J. De Nova III  
*Administrator*  
Matthew P. Jordan, Esq.  
*County Counsel*  
Louis E. Imhof, III, RMC  
*Clerk Of The Board*



## Public Meeting (Board Meeting)

Date: Aug 10, 2021 - 5:30 PM

Location: County Administration Building  
Webex - 220  
401 Grand Street  
Paterson, NJ 07505

Agenda: RESOLUTION RETAINING ERIC M. BERNSTEIN & ASSOCIATES, LLC FOR OUTSIDE LEGAL SERVICES IN VARIOUS MATTERS, PURSUANT TO N.J.S.A. 40A:11-5, ET SEQ., ALL AS NOTED IN THE RESOLUTION.

THIS RESOLUTION WAS REQUESTED BY:

COUNTY COUNSEL

REVIEWED BY:

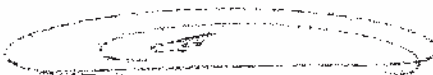
  
Anthony J. De Nova III

COUNTY ADMINISTRATOR

APPROVED AS TO FORM AND LEGALITY:

  
Matthew P. Jordan, Esq.

COUNTY COUNSEL

Administration and Finance

COMMITTEE NAME

<b>Official Resolution#</b>	<b>R20210727</b>							
Meeting Date	08/10/2021							
Introduced Date	08/10/2021							
Adopted Date	08/10/2021							
Agenda Item	I-11							
CAF #	T-19-56-850-000-801							
Purchase Req. #	R1-13809; R1-13806							
Result	Adopted							
<b>COMMISSIONER</b>	<b>PRES.</b>	<b>ABS.</b>	<b>MOVE</b>	<b>SEC</b>	<b>AYE</b>	<b>NAY</b>	<b>ABST.</b>	<b>RECU.</b>
Lepore	✓				✓			
James	✓		✓		✓			
Akhter	✓			✓	✓			
Bartlett	✓				✓			
Best Jr.	✓				✓			
Duffy	✓				✓			
Lazzara	✓				✓			

PRES.= present ABS.= absent  
MOVE= moved SEC= seconded  
AYE= yes NAY= no ABST.= abstain  
RECU.= recuse

Dated: August 11, 2021

**RESOLUTION RETAINING ERIC M. BERNSTEIN & ASSOCIATES, LLC FOR OUTSIDE LEGAL SERVICES IN VARIOUS MATTERS, PURSUANT TO N.J.S.A. 40A:11-5, ET SEQ.**

**WHEREAS**, the County of Passaic (hereafter “County”) is a body politic and corporate pursuant to N.J.S.A. 40:18-1 and vested with all rights contained therein; and

**WHEREAS**, pursuant to N.J.S.A. 40:20-1 the Board of County Commissioners of the County of Passaic (hereafter “Board”) is vested with managing the property, finances, and affairs of the County; and

**WHEREAS**, the County is a named defendant in the following matters: (1) Dixon v. Turner, Docket No. 2:21-CV-09947-SDW-J5A pending in the United States District Court (hereafter “Dixon Matter”); and (2) Solaro v. First Energy Corp., et al., Docket No. ESX-I-1271-21 pending in Superior Court (hereafter “Solaro Matter”), requiring the retention of outside legal counsel; and

**WHEREAS**, pursuant to N.J.S.A. 40A:11-5, et seq. the County issued RFQ-21-001, seeking qualifications for a pool of outside legal counsel for calendar year 2021, to be hired on an as-needed basis, to provide professional services to the County; and

**WHEREAS**, pursuant to N.J.S.A. 19:44A-20.4, the County’s request for qualifications is a fair and open process, specifically, the qualification for the pool of outside legal counsel for calendar year 2021 is publicly advertised, awarded under a process that provides for public solicitation of qualifications, established the basis of an award and disclosure process documented in writing prior to any solicitation, and is publicly opened and announced when awarded; and

**WHEREAS**, on November 16, 2020 the Board passed Resolution No. R20200937 qualifying a pool of outside legal counsel for calendar year 2021, as recommended by the County Counsel, to be hired on an as-needed basis, which included Eric M. Bernstein & Associates, LLC; and

**WHEREAS**, the Passaic County Counsel is recommending to the Board to retain Eric M. Bernstein & Associates, LLC as follows: (1) for an amount not to exceed seventeen thousand five hundred dollars (\$17,500.00) in the Dixon Matter; and (2) for an amount not to exceed seventeen thousand five hundred dollars (\$17,500.00) in the Solaro Matter; and

**WHEREAS**, funds are available in Account No. T-19-56-850-000-801, or any other account that may be deemed appropriate by the Chief Financial Officer or his designee, and the availability of funds has been contingently certified by the Chief Financial Officer subject to sufficient funds being appropriated by the Board in the 2021 and/or subsequent years’ County budget(s), which is attached to and made part of this Resolution; and

**WHEREAS**, this matter was discussed at the July 27, 2021 meeting of the Administration and Finance Committee and is being recommended to the Board for approval; and

**NOW, THEREFORE, LET IT BE RESOLVED**, pursuant to N.J.S.A. 40A:11-5(1)(a)(i) that the Board of County Commissioners of the County of Passaic is retaining Eric M. Bernstein & Associates, LLC as follows: (1) for an amount not to exceed seventeen thousand five hundred dollars (\$17,500.00) in the Dixon Matter; and (2) for an amount not to exceed seventeen thousand five hundred dollars (\$17,500.00) in the Solaro Matter.

**LET IT BE FURTHER RESOLVED**, the Clerk of the Board shall print, in the official newspaper, a brief notice stating the nature, duration, service, and amount of the contracts to Eric M. Bernstein & Associates, LLC and maintain a copy of the Resolution on file and available for public inspection in the Office of the Clerk of the Board.

**LET IT BE FURTHER RESOLVED**, that the Clerk of the Board, County Counsel, and Director of the Board of County Commissioners are authorized to execute the contract and take any other steps necessary to carry out the purpose of this Resolution.

MPJ

August 10, 2021

COUNTY OF PASSAIC  
 INSURANCE DIV., CO OF PASSAIC  
 (O) 973-881-4421  
 401 GRAND ST. ROOM 532  
 PATERSON, NJ 07505

REQUISITION	
NO.	R1-13809

S H I P  T O	
V E N D O R	VENDOR #: L0148 ERIC M. BERNSTEIN & ASSOC. 34 MOUNTAIN BLVD, BLD A P.O. BOX 4922 WARREN, NJ 07059

ORDER DATE: 07/23/21  
 DELIVERY DATE:  
 STATE CONTRACT:  
 F.O.B. TERMS:

QTY/UNIT	DESCRIPTION	ACCOUNT NO.	UNIT PRICE	TOTAL COST
1.00	Outside counsel services For the matter of Dixon v. Turner Docket No. 2:21-CV-09947-SDW-JSA	T-19-56-850-000-801	17,500.0000	17,500.00
	DO NOT SEND PO TO VENDOR			
			TOTAL	17,500.00

Introduced on: August 10, 2021  
 Adopted on: August 10, 2021  
 Official Resolution#: R20210727

\_\_\_\_\_  
 REQUESTING DEPARTMENT DATE

COUNTY OF PASSAIC  
INSURANCE DIV., CO OF PASSAIC  
(O) 973-881-4421  
401 GRAND ST. ROOM 532  
PATERSON, NJ 07505

REQUISITION	
NO.	R1-13806

S H I P  T O	
V E N D O R	VENDOR #: L0148 ERIC M. BERNSTEIN & ASSOC. 34 MOUNTAIN BLVD, BLD A P.O. BOX 4922 WARREN, NJ 07059

ORDER DATE: 07/23/21  
DELIVERY DATE:  
STATE CONTRACT:  
F.O.B. TERMS:

QTY/UNIT	DESCRIPTION	ACCOUNT NO.	UNIT PRICE	TOTAL COST
1.00	Outside counsel services For the matter of Solaro v. First Energy Corp., Et al. Docket No. ESX-L-1271-21	T-19-56-850-000-801	17,500.0000	17,500.00
	DO NOT SEND PO TO VENDOR			
			TOTAL	17,500.00

Introduced on: August 10, 2021  
Adopted on: August 10, 2021  
Official Resolution#: R20210727

\_\_\_\_\_  
REQUESTING DEPARTMENT DATE

CERTIFICATION OF AVAILABLE FUNDS

THIS IS TO CERTIFY THAT FUNDS ARE AVAILABLE AS FOLLOWS:

AMOUNT: \$35,000.00

APPROPRIATION: T-19-56-850-000-801

PURPOSE: Authorizing the retaining of Eric M. Bernstein & Associates for outside legal services in various matters.

  
Richard Cahill, Director of Finance

DATED: August 10, 2021

# County of Passaic Board of County Commissioners

OFFICE OF COUNTY COMMISSIONERS

Director Pasquale "Pat" Lepore  
Deputy Director Bruce James  
Assad R. Akhter  
John W. Bartlett  
Theodore O. Best, Jr.  
Terry Duffy  
Cassandra "Sandi" Lazzara

401 Grand Street  
Paterson, New Jersey 07505

Tel: 973-881-4402  
Fax: 973-742-3746

Anthony J. De Nova III  
Administrator

Matthew P. Jordan, Esq.  
County Counsel

Louis E. Imhof, III, RMC  
Clerk Of The Board



## Public Meeting (Board Meeting)

Date: Aug 10, 2021 - 5:30 PM

Location: County Administration Building  
Webex - 220  
401 Grand Street  
Paterson, NJ 07505

Agenda: RESOLUTION AUTHORIZING THE PURCHASE OF SOFTWARE FOR ELEARNING SUBSCRIPTIONS FOR VARIOUS SOFTWARE USED BY COUNTY EMPLOYEES FROM SHI INTERNATIONAL CORP., PURSUANT TO N.J.S.A. 40A:11-10, ET SEQ., ALL AS NOTED IN THE RESOLUTION.

THIS RESOLUTION WAS REQUESTED BY:

PURCHASING

REVIEWED BY:

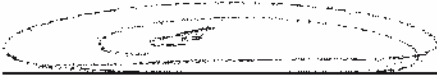
  
Anthony J. De Nova III  
COUNTY ADMINISTRATOR

APPROVED AS TO FORM AND LEGALITY:

  
Matthew P. Jordan, Esq.  
COUNTY COUNSEL

Administration and Finance

COMMITTEE NAME

<b>Official Resolution#</b>	<b>R20210728</b>							
Meeting Date	08/10/2021							
Introduced Date	08/10/2021							
Adopted Date	08/10/2021							
Agenda Item	I-12							
CAF #	1-01-20-111-003-219							
Purchase Req. #	R1-13768							
Result	Adopted							
<b>COMMISSIONER</b>	<b>PRES.</b>	<b>ABS.</b>	<b>MOVE</b>	<b>SEC</b>	<b>AYE</b>	<b>NAY</b>	<b>ABST.</b>	<b>RECU.</b>
Lepore	✓				✓			
James	✓		✓		✓			
Akhter	✓			✓	✓			
Bartlett	✓				✓			
Best Jr.	✓				✓			
Duffy	✓				✓			
Lazzara	✓				✓			

PRES.= present ABS.= absent  
 MOVE= moved SEC= seconded  
 AYE= yes NAY= no ABST.= abstain  
 RECU.= recuse

Dated: August 11, 2021

**RESOLUTION AUTHORIZING THE PURCHASE OF SOFTWARE FOR ELEARNING SUBSCRIPTIONS FOR VARIOUS SOFTWARE USED BY COUNTY EMPLOYEES FROM SHI INTERNATIONAL CORP., PURSUANT TO N.J.S.A. 40A:11-10, ET SEQ.**

**WHEREAS**, the County of Passaic (hereafter “County”) is a body politic and corporate pursuant to N.J.S.A. 40:18-1 and vested with all rights contained therein; and

**WHEREAS**, pursuant to N.J.S.A. 40:20-1 the Board of County Commissioners of the County of Passaic (hereafter “Board”) is vested with managing the property, finances, and affairs of the County; and

**WHEREAS**, N.J.S.A. 40A:11-10, et seq. the governing bodies of two or more contracting units may provide by joint agreement for the provision and performance of goods and services for use by their respective jurisdictions; and

**WHEREAS**, the County is a member of Bergen County Cooperative Contract Purchasing System, Coop No. 11BCCPS (hereafter “BCCPS”) a joint cooperative pricing system offering competitive pricing for various goods and services; and

**WHEREAS**, in compliance with the law, BCCPS issued and awarded a contract to various vendors, Computer Equipment & Peripherals, NJCPA Coop BC-Bid 19-34, which included SHI International Corp.; and

**WHEREAS**, the Director of the Department of Management and Information Systems is seeking authorization to award a contract to SHI International Corp. for an eLearning subscriptions for various software used by County employees in an amount not to exceed thirty five thousand five hundred dollars (\$35,500.00); and

**WHEREAS**, funds are available in Account No. 1-01-20-111-003-219, or any other account that may be deemed appropriate by the Chief Financial Officer or his designee, and the availability of funds has been contingently certified by the Chief Financial Officer subject to sufficient funds being appropriated by the Board in the 2021 and/or subsequent years’ County budget(s), which is attached to and made part of this Resolution; and

**WHEREAS**, this matter was discussed at the July 27, 2021 Administration and Finance Committee, and is being recommended to the Board for approval; and

**NOW, THEREFORE, LET IT BE RESOLVED**, pursuant to N.J.S.A. 40A:11-10, et seq. that the Board of County Commissioners of the County of Passaic authorizes an award of contract to SHI International Corp. for an eLearning subscriptions for various software used by County employees in an amount not to exceed thirty five thousand five hundred dollars (\$35,500.00).

**LET IT BE FURTHER RESOLVED**, that the Clerk of the Board, County Counsel, Chief Financial Officer, and Purchasing Agent are authorized to take any action necessary to carry out the purposes of this Resolution.

MPJ

August 10, 2021





Pricing Proposal  
 Quotation #: 20607332  
 Created On: 6/14/2021  
 Valid Until: 9/30/2021

---

**COUNTY OF PASSAIC**

---

**Micah Hassinger**

401 Grand St,  
 Rm 101  
 Paterson, NJ 07524  
 United States  
 Phone: 9733895940  
 Fax:  
 Email: micahh@passaiccountynj.org

---

**Account Executive**

---

**John Turba**

300 Davidson Ave,  
 Somerset NJ 08873  
 Phone: 201-953-0265  
 Fax:  
 Email: John\_Turba@shi.com

All Prices are in US Dollar (USD)

Product	Qty	Your Price	Total
1 SHI eLearning – Sheriff's Office Subscription SHI CTG - Part#: NPN Contract Name: New Jersey Cooperative Purchasing Alliance Contract #: CK04 Subcontract #: 19-34 Note: 1 Year, 800 Users	800	\$10.00	\$8,000.00
2 SHI eLearning – Sheriff's Office Subscription Business Productivity Channel Add On SHI CTG - Part#: NPN Contract Name: New Jersey Cooperative Purchasing Alliance Contract #: CK04 Subcontract #: 19-34 Note: 1 Year, 800 Users	800	\$3.75	\$3,000.00
3 SHI eLearning – Sheriff's Office Subscription HR Enablement Channel Add On SHI CTG - Part#: NPN Contract Name: New Jersey Cooperative Purchasing Alliance Contract #: CK04 Subcontract #: 19-34 Note: 1 Year, 800 Users	800	\$3.75	\$3,000.00
4 SHI eLearning – Sheriff's Office Subscription Cisco WebEx Channel Add On SHI CTG - Part#: NPN Contract Name: New Jersey Cooperative Purchasing Alliance Contract #: CK04 Subcontract #: 19-34 Note: 1 Year, 800 Users	800	\$3.75	\$3,000.00
5 SHI eLearning – Passaic County IT Admin Office Subscription SHI CTG - Part#: NPN Contract Name: New Jersey Cooperative Purchasing Alliance Contract #: CK04 Subcontract #: 19-34 Note: 1 Year, 1,000 Users	1000	\$9.50	\$9,500.00
6 SHI eLearning – Passaic County IT Admin Office Subscription Business Productivity Channel Add On	1000	\$3.00	\$3,000.00

Introduced on: August 10, 2021  
 Adopted on: August 10, 2021  
 Official Resolution#: R20210728

SHI CTG - Part#: NPN  
 Contract Name: New Jersey Cooperative Purchasing Alliance  
 Contract #: CK04  
 Subcontract #: 19-34  
 Note: 1 Year, 1,000 Users

7	SHI eLearning – Passaic County IT Admin Office Subscription HR Enablement Channel Add On SHI CTG - Part#: NPN Contract Name: New Jersey Cooperative Purchasing Alliance Contract #: CK04 Subcontract #: 19-34 Note: 1 Year, 1000 Users	1000	\$3.00	\$3,000.00
8	SHI eLearning – Passaic County IT Admin Office Subscription Cisco WebEx Channel Add On SHI CTG - Part#: NPN Contract Name: New Jersey Cooperative Purchasing Alliance Contract #: CK04 Subcontract #: 19-34 Note: 1 Year, 1000 Users	1000	\$3.00	\$3,000.00
			Total	\$35,500.00

**Additional Comments**

Please note, if Emergency Connectivity Funds (ECF) will be used to pay for all or part of this quote, please let us know as we will need to ensure compliance with the funding program.

Please send vouchers to 290 Davidson Ave, Somerset NJ 08873

Note: The New Jersey Cooperative Purchasing Alliance is a Service of the County of Bergen, County Executive James J. Tedesco III and the Board of Chosen Freeholders.

Hardware items on this quote may be updated to reflect changes due to industry wide constraints and fluctuations.

Thank you for choosing SHI International Corp! The pricing offered on this quote proposal is valid through the expiration date listed above. To ensure the best level of service, please provide End User Name, Phone Number, Email Address and applicable Contract Number when submitting a Purchase Order. For any additional information including Hardware, Software and Services Contracts, please contact an SHI Inside Sales Representative at (888) 744-4084. SHI International Corp. is 100% Minority Owned, Woman Owned Business. TAX ID# 22-3009648; DUNS# 61-1429481; CCR# 61-243957G; CAGE 1HTF0

*The products offered under this proposal are resold in accordance with the terms and conditions of the Contract referenced under that applicable line item.*

Introduced on: August 10, 2021  
 Adopted on: August 10, 2021  
 Official Resolution#: R20210728

COUNTY OF PASSAIC  
 MIS DEPT (Q) 973-754-6855  
 COUNTY OF PASSAIC  
 401 GRAND ST. RM 101  
 PATERSON, NJ 07505

REQUISITION	
NO.	R1-13768

S H I P  T O	COUNTY OF PASSAIC MIS DEPT 401 GRAND ST. RM 101 PATERSON, NJ 07505
V E N D O R	VENDOR #: 08638 SHI INTERNATIONAL, CORP. 290 DAVIDSON AVENUE SOMERSET, NJ 08873

ORDER DATE: 07/21/21  
 DELIVERY DATE:  
 STATE CONTRACT: CK04/19-34  
 F.O.B. TERMS:

QTY/UNIT	DESCRIPTION	ACCOUNT NO.	UNIT PRICE	TOTAL COST
800.00	PCSD 1 year Catalog #: NPN	1-01-20-111-003-219	10.0000	8,000.00
800.00	PCSD 1 year, Productivity	1-01-20-111-003-219	3.7500	3,000.00
800.00	PCSD 1 year HR	1-01-20-111-003-219	3.7500	3,000.00
800.00	PCSD 1 year WebEx	1-01-20-111-003-219	3.7500	3,000.00
1000.00	County 1 year	1-01-20-111-003-219	9.5000	9,500.00
1000.00	County 1 year Productivity	1-01-20-111-003-219	3.0000	3,000.00
1000.00	County 1 year HR	1-01-20-111-003-219	3.0000	3,000.00
1000.00	County 1 year WebEx	1-01-20-111-003-219	3.0000	3,000.00
	As per quote 20607332 Dated 6/14/21			
	Pending Reso.			
	For County Use			
			TOTAL	35,500.00

REQUESTING DEPARTMENT

DATE

Introduced on: August 10, 2021  
 Adopted on: August 10, 2021  
 Official Resolution#: R20210728

CERTIFICATION OF AVAILABLE FUNDS

THIS IS TO CERTIFY THAT FUNDS ARE AVAILABLE AS FOLLOWS:

AMOUNT: \$35,500.00

APPROPRIATION: 1-01-20-111-003-219

PURPOSE: Authorizing purchase of software for eLearning subscriptions for various software used by County employees.

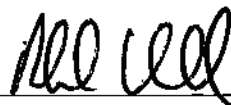

Richard Cahill, Director of Finance

DATED: August 10, 2021

# County of Passaic Board of County Commissioners

OFFICE OF COUNTY COMMISSIONERS

Director Pasquale "Pat" Lepore  
Deputy Director Bruce James  
Assad R. Akhter  
John W. Bartlett  
Theodore O. Best, Jr.  
Terry Duffy  
Cassandra "Sandi" Lazzara

401 Grand Street  
Paterson, New Jersey 07505

Tel: 973-881-4402  
Fax: 973-742-3746

Anthony J. De Nova III  
Administrator

Matthew P. Jordan, Esq.  
County Counsel

Louis E. Imhof, III, RMC  
Clerk Of The Board



## Public Meeting (Board Meeting)

Date: Aug 10, 2021 - 5:30 PM

Location: County Administration Building  
Webex - 220  
401 Grand Street  
Paterson, NJ 07505

Agenda: RESOLUTION AUTHORIZING A THIRD AMENDMENT TO THE OMNIBUS PURCHASING RESOLUTION FOR CALENDAR YEAR 2021, PURSUANT TO N.J.S.A. 40A:11-12, ET SEQ., ALL AS NOTED IN THE RESOLUTION.

THIS RESOLUTION WAS REQUESTED BY:

PURCHASING

REVIEWED BY:

Anthony J. De Nova III

COUNTY ADMINISTRATOR

APPROVED AS TO FORM AND LEGALITY:

Matthew P. Jordan, Esq.

COUNTY COUNSEL

Administration and Finance

COMMITTEE NAME

<b>Official Resolution#</b>	<b>R20210729</b>							
Meeting Date	08/10/2021							
Introduced Date	08/10/2021							
Adopted Date	08/10/2021							
Agenda Item	I-13							
CAF #								
Purchase Req. #								
Result	Adopted							
<b>COMMISSIONER</b>	<b>PRES.</b>	<b>ABS.</b>	<b>MOVE</b>	<b>SEC</b>	<b>AYE</b>	<b>NAY</b>	<b>ABST.</b>	<b>RECU.</b>
Lepore	✓				✓			
James	✓		✓		✓			
Akhter	✓			✓	✓			
Bartlett	✓				✓			
Best Jr.	✓				✓			
Duffy	✓				✓			
Lazzara	✓				✓			

PRES.= present ABS.= absent  
MOVE= moved SEC= seconded  
AYE= yes NAY= no ABST.= abstain  
RECU.= recuse

**Dated: August 11, 2021**

**RESOLUTION AUTHORIZING A THIRD AMENDMENT TO THE OMNIBUS PURCHASING RESOLUTION FOR CALENDAR YEAR 2021, PURSUANT TO N.J.S.A. 40A:11-12, ET SEQ.**

**WHEREAS**, the County of Passaic (hereafter “County”) is a body politic and corporate pursuant to N.J.S.A. 40:18-1 and vested with all rights contained therein; and

**WHEREAS**, pursuant to N.J.S.A. 40:20-1 the Board of County Commissioners of the County of Passaic (hereafter “Board”) is vested with managing the property, finances, and affairs of the County; and

**WHEREAS**, on December 28, 2020 the Board approved Resolution No. R20201152, approving the Omnibus Purchasing Resolution for Calendar Year 2021, authorizing various appropriations pursuant to N.J.S.A. 40A:11-10, et seq. and N.J.S.A. 40A:11-12, et seq. (hereafter “Omnibus Resolution”); and

**WHEREAS**, on March 23, 2021 the Board approved Resolution No. R20210279 amending the Omnibus Resolution, in accordance with the law; and

**WHEREAS**, on April 27, 2021 the Board approved Resolution No. R20210404 authorizing a second amendment to the Omnibus Resolution, in accordance with the law; and

**WHEREAS**, pursuant to N.J.S.A. 40:11-12, et seq., the County may, without advertising for bids, or having rejected all bids obtained pursuant to advertising thereof, purchase any goods or services under any contract or contracts for such goods or services entered into on behalf of the State of New Jersey by the Division of Purchase and Property in the Department of Treasury;

**WHEREAS**, Rachles/Micheles Oil Company submitted competitive pricing for Unleaded Automotive Gasoline, Master Blanket Purchase Order No. 00973, to the State of New Jersey, Division of Purchase and Property in the Department of Treasury; and

**WHEREAS**, the Purchasing Agent is seeking to amend the Omnibus Resolution for a third time, authorizing an appropriation in an amount not to exceed six hundred thousand dollars (\$600,000.00) to be used by various County departments on an as-needed basis; and

**WHEREAS**, funds are available in an account that may be deemed appropriate by the Chief Financial Officer or his designee, and the availability of funds has been contingently certified by the Chief Financial Officer subject to sufficient funds being appropriated by the Board in the 2021 and/or subsequent years’ County budget(s), which is attached to and made part of this Resolution; and

**WHEREAS**, this matter was discussed at the July 27, 2021 Administration and Finance Committee, and is being recommended to the Board for approval; and

**NOW, THEREFORE, LET IT BE RESOLVED**, pursuant to N.J.S.A. 40A:11-12, et seq. that the Board of County Commissioners of the County of Passaic amends the Omnibus Purchasing Resolution for Calendar Year 2021 to include an appropriation for Rachles/Micheles Oil Company in an amount not to exceed six hundred thousand dollars (\$600,000.00) to be used by various County departments on an as-needed basis.

**LET IT BE FURTHER RESOLVED** that the Chief Financial Officer, County Counsel, and Purchasing Agent are authorized to take any action necessary to carry out the purpose of this Resolution.

MPJ

August 10, 2021

CERTIFICATION OF AVAILABLE FUNDS

THIS IS TO CERTIFY THAT FUNDS ARE AVAILABLE AS FOLLOWS:

AMOUNT: \$600,000.00

APPROPRIATION: All Accounts

PURPOSE: Awarding contract to Racheles/Micheles Oil Company.



Richard Cahill, Director of Finance

DATED: August 10, 2021

# County of Passaic Board of County Commissioners

OFFICE OF COUNTY COMMISSIONERS

Director Pasquale "Pat" Lepore  
Deputy Director Bruce James  
Assad R. Akhter  
John W. Bartlett  
Theodore O. Best, Jr.  
Terry Duffy  
Cassandra "Sandi" Lazzara

401 Grand Street  
Paterson, New Jersey 07505  
Tel: 973-881-4402  
Fax: 973-742-3746

Anthony J. De Nova III  
*Administrator*  
Matthew P. Jordan, Esq.  
*County Counsel*  
Louis E. Imhof, III, RMC  
*Clerk Of The Board*



## Public Meeting (Board Meeting)

Date: Aug 10, 2021 - 5:30 PM

Location: County Administration Building  
Webex - 220  
401 Grand Street  
Paterson, NJ 07505

Agenda: RESOLUTION AUTHORIZING THE CHIEF FINANCIAL OFFICER TO EXECUTE BUDGET TRANSFERS BETWEEN PREVIOUSLY-APPROVED OPEN SPACE, FARMLAND, AND HISTORIC PRESERVATION TRUST FUND BUDGETS, PURSUANT TO N.J.S.A. 40:20-1, ALL AS NOTED IN THE RESOLUTION.

THIS RESOLUTION WAS REQUESTED BY:

REVIEWED BY:

Anthony J. De Nova III  
COUNTY ADMINISTRATOR

APPROVED AS TO FORM AND LEGALITY:

Matthew P. Jordan, Esq.  
COUNTY COUNSEL

Administration and Finance  
COMMITTEE NAME

<b>Official Resolution#</b>	<b>R20210730</b>							
Meeting Date	08/10/2021							
Introduced Date	08/10/2021							
Adopted Date	08/10/2021							
Agenda Item	I-14							
CAF #								
Purchase Req. #								
Result	Adopted							
<b>COMMISSIONER</b>	<b>PRES.</b>	<b>ABS.</b>	<b>MOVE</b>	<b>SEC</b>	<b>AYE</b>	<b>NAY</b>	<b>ABST.</b>	<b>RECU.</b>
Lepore	✓				✓			
James	✓		✓		✓			
Akhter	✓			✓	✓			
Bartlett	✓				✓			
Best Jr.	✓				✓			
Duffy	✓				✓			
Lazzara	✓				✓			

PRES.= present ABS.= absent  
MOVE= moved SEC= seconded  
AYE= yes NAY= no ABST.= abstain  
RECU.= recuse

**Dated: August 11, 2021**



**RESOLUTION AUTHORIZING THE CHIEF FINANCIAL OFFICER TO EXECUTE BUDGET TRANSFERS BETWEEN PREVIOUSLY APPROVED OPEN SPACE, FARMLAND, AND HISTORIC PRESERVATION TRUST FUND BUDGETS, PURSUANT TO N.J.S.A. 40:20-1**

**WHEREAS**, the County of Passaic (hereafter “County”) is a body politic and corporate pursuant to N.J.S.A. 40:18-1 and vested with all rights contained therein; and

**WHEREAS**, pursuant to N.J.S.A. 40:20-1, the Board of County Commissioners of the County of Passaic (hereafter “Board”) is vested with managing the property, finances, and affairs of the County; and

**WHEREAS**, on April 15, 2017 the Board approved Resolution No. R20170401 adopting a uniform body of rules and regulations governing the Open Space, Farmland, and Historic Preservation Trust Fund (hereafter “Rules”); and

**WHEREAS**, Chapter 16 of the Rules requires the Board to pass a yearly budget for appropriations from the Open Space, Farmland, and Historic Preservation Trust Fund, outlining improvement projects and other allowable expenses within the Passaic County Park System; and

**WHEREAS**, on February 23, 2016, the Board approved Resolution No. R20160134 authorizing the 2016 Open Space, Farmland, and Historic Preservation Trust Fund Budget (hereafter “2016 OSTF Budget”); and

**WHEREAS**, on January 22, 2019, the Board approved Resolution No. R20190034, authorizing the 2019 Open Space, Farmland, and Historic Preservation Trust Fund Budget (hereafter “2019 OSTF Budget”); and

**WHEREAS**, on January 28, 2020, the Board approved Resolution No. R20200030, authorizing the 2020 Open Space, Farmland, and Historic Preservation Trust Fund Budget (hereafter “2020 OSTF Budget”); and

**WHEREAS**, on January 26, 2021, the Board approved Resolution No. R20210038, authorizing the 2021 Open Space, Farmland, and Historic Preservation Trust Fund Budget (hereafter “2021 OSTF Budget”); and

**WHEREAS**, because of the completion of various improvement projects approved by the Board from the 2016 OSTF Budget, 2019 OSTF Budget, 2020 OSTF Budget, and 2021 OSTF Budget, it is being recommended that funds be reappropriated, as set forth below; and

**WHEREAS**, this matter was discussed at the July 27, 2021 meeting of the Administration and Finance Committee, and is being recommended to the Board for approval.

**NOW, THEREFORE, LET IT BE RESOLVED**, pursuant to N.J.S.A. 40:20-1, that the Board of County Commissioners of the County of Passaic authorizes the Chief Financial Officer to amend the appropriations in the Open Space, Farmland, and Historic Preservation Trust Fund Budget as follows:

ACCOUNT	TITLE	FROM	TO
O-16-56-715-000-603	Countywide Wayfinding System – OE	\$3,096.39	
O-19-56-665-000-602	Wayfinding System – OE	\$17,024.00	
O-20-56-651-003-603	Historic Landscape Restoration Project – OE	\$9,939.61	
O-21-56-645-003-600	Preakness Valley Golf Course – OE		\$30,060.00
O-21-56-660-001-602	Highlands Rail Trail – OE	\$50.00	
O-21-56-610-002-604	OSTF Misc. Items - OE		\$50.00
	<b>TOTAL</b>	\$30,110.00	\$30,110.00

**LET IT BE FURTHER RESOLVED**, that the Chief Financial Officer is authorized to take any other steps necessary to carry out the purpose of this Resolution.

MPJ

August 10, 2021

# County of Passaic Board of County Commissioners

OFFICE OF COUNTY COMMISSIONERS

Director Pasquale "Pat" Lepore  
Deputy Director Bruce James  
Assad R. Akhter  
John W. Bartlett  
Theodore O. Best, Jr.  
Terry Duffy  
Cassandra "Sandi" Lazzara

401 Grand Street  
Paterson, New Jersey 07505  
Tel: 973-881-4402  
Fax: 973-742-3746

Anthony J. De Nova III  
*Administrator*  
Matthew P. Jordan, Esq.  
*County Counsel*  
Louis E. Imhof, III, RMC  
*Clerk Of The Board*



## Public Meeting (Board Meeting)

Date: Aug 10, 2021 - 5:30 PM

Location: County Administration Building  
Webex - 220  
401 Grand Street  
Paterson, NJ 07505

Agenda: RESOLUTION AUTHORIZING ADDITIONAL LEGAL FEE AUTHORIZATION FOR HOAGLAND LONGO MORAN DUNST & DUKAS, LLP IN JACKSON V. COUNTY OF PASSAIC, ET AL, DOCKET NO. BER-L-004351-21, PURSUANT TO N.J.A.C. 5:30-11.6, ALL AS NOTED IN THE RESOLUTION.

THIS RESOLUTION WAS REQUESTED BY:

REVIEWED BY:

Anthony J. De Nova III  
COUNTY ADMINISTRATOR

APPROVED AS TO FORM AND LEGALITY:

Matthew P. Jordan, Esq.  
COUNTY COUNSEL

Administration and Finance  
COMMITTEE NAME

<b>Official Resolution#</b>	<b>R20210731</b>							
Meeting Date	08/10/2021							
Introduced Date	08/10/2021							
Adopted Date	08/10/2021							
Agenda Item	I-15							
CAF #	T-19-56-850-000-801							
Purchase Req. #								
Result	Adopted							
<b>COMMISSIONER</b>	<b>PRES.</b>	<b>ABS.</b>	<b>MOVE</b>	<b>SEC</b>	<b>AYE</b>	<b>NAY</b>	<b>ABST.</b>	<b>RECU.</b>
Lepore	✓				✓			
James	✓		✓		✓			
Akhter	✓			✓	✓			
Bartlett	✓				✓			
Best Jr.	✓				✓			
Duffy	✓				✓			
Lazzara	✓				✓			

PRES.= present ABS.= absent  
MOVE= moved SEC= seconded  
AYE= yes NAY= no ABST.= abstain  
RECU.= recuse

Dated: August 11, 2021

**RESOLUTION AUTHORIZING ADDITIONAL LEGAL FEE AUTHORIZATION FOR HOAGLAND LONGO MORAN DUNST & DUKAS, LLP IN JACKSON V. COUNTY OF PASSAIC, ET AL, DOCKET NO. BER-L-004351-21, PURSUANT TO N.J.A.C. 5:30-11.6**

**WHEREAS**, the County of Passaic (hereafter “County”) is a body politic and corporate pursuant to N.J.S.A. 40:18-1 and vested with all rights contained therein; and

**WHEREAS**, pursuant to N.J.S.A. 40:20-1 the Board of County Commissioners of the County of Passaic (hereafter “Board”) is vested with managing the property, finances, and affairs of the County; and

**WHEREAS**, the County is a named party in the matter of Jackson v. County of Passaic, et al., Docket No. BER-L-00435-21, pending in the Superior Court of New Jersey (hereafter the “Jackson Matter”); and

**WHEREAS**, pursuant to N.J.S.A. 40A:11-5, et seq. the County issued RFQ-21-001, seeking qualifications for a pool of outside legal counsel for calendar year 2021, to be hired on an as-needed basis, to provide professional services to the County; and

**WHEREAS**, pursuant to N.J.S.A. 19:44A-20.4, the County’s request for qualifications is a fair and open process, specifically, the qualification for the pool of outside legal counsel for calendar year 2021 is publicly advertised, awarded under a process that provides for public solicitation of qualifications, established the basis of an award and disclosure process documented in writing prior to any solicitation, and is publicly opened and announced when awarded; and

**WHEREAS**, on November 16, 2020, the Board approved Resolution No. R20200937 qualifying a pool of outside legal counsel and for calendar year 2021, as recommended by the Passaic County Counsel, to be hired on an as-needed basis, which included Hoagland Longo Moran Dunst & Dukas, LLP; and

**WHEREAS**, on October 8, 2019, the Board approved Resolution No. R20190862 retaining the law firm of Hoagland Longo Moran Dunst & Dukas, LLP to represent the County in the Jackson Matter; and

**WHEREAS**, pursuant to N.J.A.C. 5:30-11.6, the County can authorize contract modifications for professional services and extraordinary unspecifiable services, when the change is within the scope of activities of the original contract, and not for the purpose of undertaking new or different work or projects; and

**WHEREAS**, the Passaic County Counsel is recommending to the Board to increase the legal fee authorization for Hoagland Longo Moran Dunst & Dukas, LLP in the Jackson Matter by an amount not to exceed one hundred ninety seven thousand five hundred dollars (\$197,500.00), to provide outside legal services to the County; and

**WHEREAS**, funds are available in Account No. T-19-56-850-000-801, or any other account that may be deemed appropriate by the Chief Financial Officer or his designee, and the availability of funds has been contingently certified by the Chief Financial Officer subject to sufficient funds being appropriated by the Board in the 2021 and/or subsequent years’ County budget(s), which is attached to and made part of this Resolution; and

**WHEREAS**, this matter was discussed by Administration and Finance Committee and is being recommended to the Board for approval.

**NOW, THEREFORE, LET IT BE RESOLVED**, pursuant to N.J.A.C. 5:30-11.6, that the Board of County Commissioners of the County of Passaic authorizes the legal fee authorization for Hoagland Longo Moran Dunst & Dukas, LLP in the Jackson Matter by an amount not to exceed one hundred ninety seven thousand five hundred dollars (\$197,500.00), to provide outside legal services to the County of Passaic.

**LET IT BE FURTHER RESOLVED**, the Clerk of the Board shall print, in the official newspaper, a brief notice stating the nature, duration, service, and amount of the contract modifications

awarded herein, and maintain a copy of the resolution on file and available for public inspection in the Office of the Clerk of the Board.

**LET IT BE FURTHER RESOLVED**, that the Clerk of the Board, County Counsel, and Director of the Board of County Commissioners are authorized to execute the contracts and take any other steps necessary to carry out the purpose of this resolution.

MPJ

August 10, 2021

CERTIFICATION OF AVAILABLE FUNDS

THIS IS TO CERTIFY THAT FUNDS ARE AVAILABLE AS FOLLOWS:

AMOUNT: \$197,500.00

APPROPRIATION: T-19-56-850-000-801

PURPOSE: Authorizing additional legal fee for Hoagland Longo  
Moran Dunst & Dukas, LLP in the Jackson matter.



Richard Cahill, Director of Finance

DATED: August 10, 2021

# County of Passaic Board of County Commissioners

OFFICE OF COUNTY COMMISSIONERS

Director Pasquale "Pat" Lepore  
Deputy Director Bruce James  
Assad R. Akhter  
John W. Bartlett  
Theodore O. Best, Jr.  
Terry Duffy  
Cassandra "Sandi" Lazzara

401 Grand Street  
Paterson, New Jersey 07505  
Tel: 973-881-4402  
Fax: 973-742-3746

Anthony J. De Nova III  
*Administrator*  
Matthew P. Jordan, Esq.  
*County Counsel*  
Louis E. Imhof, III, RMC  
*Clerk Of The Board*



## Public Meeting (Board Meeting)

Date: Aug 10, 2021 - 5:30 PM

Location: County Administration Building  
Webex - 220  
401 Grand Street  
Paterson, NJ 07505

Agenda: RESOLUTION AUTHORIZING THE SETTLEMENT OF LITIGATION ENTITLED, JOHN PIERSON V. COUNTY OF PASSAIC, CLAIM PETITION NO. 2011-34209, PENDING IN THE NEW JERSEY DIVISION OF WORKERS' COMPENSATION, PURSUANT TO N.J.S.A. 40:20-1, ALL AS NOTED IN THE RESOLUTION.

THIS RESOLUTION WAS REQUESTED BY:

REVIEWED BY:

Anthony J. De Nova III  
COUNTY ADMINISTRATOR

APPROVED AS TO FORM AND LEGALITY:

Matthew P. Jordan, Esq.  
COUNTY COUNSEL

Administration and Finance  
COMMITTEE NAME

<b>Official Resolution#</b>	<b>R20210732</b>							
Meeting Date	08/10/2021							
Introduced Date	08/10/2021							
Adopted Date	08/10/2021							
Agenda Item	I-16							
CAF #	T-18-56-850-000-801							
Purchase Req. #								
Result	Adopted							
<b>COMMISSIONER</b>	<b>PRES.</b>	<b>ABS.</b>	<b>MOVE</b>	<b>SEC</b>	<b>AYE</b>	<b>NAY</b>	<b>ABST.</b>	<b>RECU.</b>
Lepore	✓				✓			
James	✓		✓		✓			
Akhter	✓			✓	✓			
Bartlett	✓				✓			
Best Jr.	✓				✓			
Duffy	✓				✓			
Lazzara	✓				✓			

PRES.= present ABS.= absent  
MOVE= moved SEC= seconded  
AYE= yes NAY= no ABST.= abstain  
RECU.= recuse

Dated: August 11, 2021

**RESOLUTION AUTHORIZING THE SETTLEMENT OF LITIGATION ENTITLED, JOHN PIERSON V. COUNTY OF PASSAIC, CLAIM PETITION NO. 2011-34209, PENDING IN THE NEW JERSEY DIVISION OF WORKERS' COMPENSATION, PURSUANT TO N.J.S.A. 40:20-1**

**WHEREAS**, the County of Passaic (hereafter "County") is a body politic and corporate pursuant to N.J.S.A. 40:18-1 and vested with all rights contained therein; and

**WHEREAS**, pursuant to N.J.S.A. 40:20-1 the Board of County Commissioners of the County of Passaic (hereafter "Board") is vested with managing the property, finances, and affairs of the County; and

**WHEREAS**, the County is the respondent in John Pierson v. County of Passaic, Claim Petition No. 2011-34209, pending in the New Jersey Division of Workers' Compensation; and

**WHEREAS**, the County's outside legal counsel for workers' compensation matters and third party administrator for general liability and workers' compensation claims are recommending a settlement in this matter in an amount not to exceed one hundred seventy nine thousand two hundred and eighty four dollars (\$179,284.00); and

**WHEREAS**, funds are available in Account No. T-18-56-850-000-801, or any other account that may be deemed appropriate by the Chief Financial Officer or his designee, and the availability of funds has been contingently certified by the Chief Financial Officer subject to sufficient funds being appropriated by the Board in the 2021 and/or subsequent years' County budget(s), which is attached to and made part of this Resolution; and

**WHEREAS**, this matter was discussed at the August 5, 2021 meeting of the Insurance Commission and is being recommended to the Board for approval.

**NOW, THEREFORE, LET IT BE RESOLVED**, pursuant to N.J.S.A. 40:20-1, that the Board of County Commissioners of the County of Passaic authorizes the following settlement of John Pierson v. County of Passaic, Claim Petition No. 2011-34209, pending in the New Jersey Division of Workers' Compensation, in an amount not to exceed one hundred seventy nine thousand two hundred and eighty four dollars (\$179,284.00).

**LET IT BE FURTHER RESOLVED** that the Clerk of the Board, County Counsel, Chief Financial Officer, and Director of the Board of County Commissioners are authorized to take all steps necessary to carry out the purpose of this Resolution.

MPJ

August 10, 2021

CERTIFICATION OF AVAILABLE FUNDS

THIS IS TO CERTIFY THAT FUNDS ARE AVAILABLE AS FOLLOWS:

AMOUNT: \$179,284.00

APPROPRIATION: T-18-56-850-000-801

PURPOSE: Authorizing the settlement of litigation entitled, John Pierson v. County of Passaic, Claim Petition No. 2011-34209 pending the New Jersey Division of Workers' Compensation.



Richard Cahill, Director of Finance

DATED: August 10, 2021



# County of Passaic Board of County Commissioners

OFFICE OF COUNTY COMMISSIONERS

Director Pasquale "Pat" Lepore  
Deputy Director Bruce James  
Assad R. Akhter  
John W. Bartlett  
Theodore O. Best, Jr.  
Terry Duffy  
Cassandra "Sandi" Lazzara

401 Grand Street  
Paterson, New Jersey 07505  
Tel: 973-881-4402  
Fax: 973-742-3746

Anthony J. De Nova III  
*Administrator*  
Matthew P. Jordan, Esq.  
*County Counsel*  
Louis E. Imhof, III, RMC  
*Clerk Of The Board*



## Public Meeting (Board Meeting)

Date: Aug 10, 2021 - 5:30 PM

Location: County Administration Building  
Webex - 220  
401 Grand Street  
Paterson, NJ 07505

Agenda: RESOLUTION AUTHORIZING THE CREATION OF THE PASSAIC COUNTY JAIL ASSESSMENT COMMITTEE; DIRECTING THE COUNTY ADMINISTRATOR TO EXPLORE OPTIONS RELATED TO SAME, INCLUDING REBUILDING OR CONSOLIDATING THE OPERATIONS OF THE PASSAIC COUNTY JAIL, PURSUANT TO N.J.S.A. 40A:65-1, ET SEQ., ALL AS NOTED IN THE RESOLUTION.

THIS RESOLUTION WAS REQUESTED BY:

REVIEWED BY:

Anthony J. De Nova III  
COUNTY ADMINISTRATOR

APPROVED AS TO FORM AND LEGALITY:

Matthew P. Jordan, Esq.  
COUNTY COUNSEL

Administration and Finance  
COMMITTEE NAME

<b>Official Resolution#</b>	<b>R20210733</b>							
Meeting Date	08/10/2021							
Introduced Date	08/10/2021							
Adopted Date	08/10/2021							
Agenda Item	I-17							
CAF #								
Purchase Req. #								
Result	Adopted							
<b>COMMISSIONER</b>	<b>PRES.</b>	<b>ABS.</b>	<b>MOVE</b>	<b>SEC</b>	<b>AYE</b>	<b>NAY</b>	<b>ABST.</b>	<b>RECU.</b>
Lepore	✓				✓			
James	✓		✓		✓			
Akhter	✓			✓	✓			
Bartlett	✓				✓			
Best Jr.	✓				✓			
Duffy	✓				✓			
Lazzara	✓				✓			

PRES.= present ABS.= absent  
 MOVE= moved SEC= seconded  
 AYE= yes NAY= no ABST.= abstain  
 RECU.= recuse

Dated: August 11, 2021

**RESOLUTION AUTHORIZING THE CREATION OF THE PASSAIC COUNTY JAIL ASSESSMENT COMMITTEE; DIRECTING THE COUNTY ADMINISTRATOR TO EXPLORE OPTIONS RELATED TO SAME, INCLUDING REBUILDING OR CONSOLIDATING THE OPERATIONS OF THE PASSAIC COUNTY JAIL, PURSUANT TO N.J.S.A. 40A:65-1, ET SEQ.**

**WHEREAS**, the County of Passaic (hereafter “County”) is a body politic and corporate pursuant to N.J.S.A. 40:18-1 and vested with all rights contained therein; and

**WHEREAS**, pursuant to N.J.S.A. 40:20-1 the Board of County Commissioners for the County of Passaic (hereafter “Board”) is vested with managing the property, finances, and affairs of the County; and

**WHEREAS**, the Uniform Shared Services and Consolidation Act, N.J.S.A. 40A:65-1, et seq. (hereafter the “Act”) authorizes the County to enter into an agreement with any other local unit or units to provide or receive any service that each local unit is empowered to receive in its own jurisdiction; and

**WHEREAS**, N.J.S.A. 40A:65-2 (c) declares that the Act was adopted by the Legislature to enact a new shared services statute that can be used to effectuate agreements between local units for any service or circumstance intended to reduce property taxes through the reduction of local expenses; and

**WHEREAS**, pursuant to N.J.S.A. 30:8-17, the Passaic County Sheriff (hereafter “Sheriff”) has the care, custody, and control of the Passaic County Jail, and is responsible for the operations therein; and

**WHEREAS**, across New Jersey, county governments have entered agreements pursuant to the Act to consolidate jail facilities to increase operational efficiencies and reduce property taxes, because of the declining number of inmates; and

**WHEREAS**, on August 11, 2014, P.L. 2014 c. 31 (“Bail Reform Law”) was signed into law, leading to sweeping changes to New Jersey’s adult criminal justice system, and significantly reducing the number of inmates housed in county penal institutions; and

**WHEREAS**, since the Bail Reform Law was adopted, jail populations throughout New Jersey have significantly declined, including in Passaic County; and

**WHEREAS**, consequently, the Board and Sheriff desire to explore the possibility of consolidating the Passaic County Jail with a neighboring local government unit pursuant to the Act, and work cooperatively with stakeholders, including collective bargaining units representing employees working in the Passaic County Jail, and community and pastoral representatives; and

**WHEREAS**, this matter was discussed by the Administration and Finance Committee, and is being recommended to the Board for approval.

**NOW, THEREFORE, LET IT BE RESOLVED**, pursuant to the N.J.S.A. 40:20-1 that the Board of County Commissioners for the County of Passaic authorizes the creation of the Passaic County Jail Assessment Committee to explore the regionalization of operations, comprised of stakeholders, including, but not limited to, the following representatives or their designees:

- (1) Director of the Board of County Commissioners
- (2) Two County Commissioners appointed by the Director of the Board of County Commissioners
- (3) Passaic County Sheriff
- (4) Passaic County Warden
- (5) Passaic County Administrator
- (6) PBA Local 197 President representing Superior Officers
- (7) PBA Local 197 President representing Rank and File Officers
- (8) Passaic County Assignment Judge
- (9) A community activist designated by the Director of the Board of County Commissioners
- (10) Passaic County Auditor
- (11) A representative from the pastoral community designated by the Director of the Board of County Commissioners
- (12) Any other representative as designed by the Director of the Board of County Commissioners

**LET IT BE FURTHER RESOLVED**, that the purpose of the Passaic County Jail Assessment Committee is to explore the options for the future of the Passaic County Jail, including reviewing

operational, logistical, and personnel issues related to the regionalization of inmates from Passaic County and work cooperatively to explore all options including potential cost saving measures to reduce the tax burden in Passaic County.

**LET IT BE FURTHER RESOLVED**, that the County Administrator is directed to begin fact finding, including negotiations with a local government unit to explore consolidating the operations of the Passaic County Jail and the costs of building a new jail, and present his findings to the Board of County Commissioners by no later than December 31, 2021.

MPJ

August 10, 2021

# County of Passaic Board of County Commissioners

OFFICE OF COUNTY COMMISSIONERS

Director Pasquale "Pat" Lepore  
Deputy Director Bruce James  
Assad R. Akhter  
John W. Bartlett  
Theodore O. Best, Jr.  
Terry Duffy  
Cassandra "Sandi" Lazzara

401 Grand Street  
Paterson, New Jersey 07505  
Tel: 973-881-4402  
Fax: 973-742-3746

Anthony J. De Nova III  
*Administrator*  
Matthew P. Jordan, Esq.  
*County Counsel*  
Louis E. Imhof, III, RMC  
*Clerk Of The Board*



## Public Meeting (Board Meeting)

Date: Aug 10, 2021 - 5:30 PM

Location: County Administration Building  
Webex - 220  
401 Grand Street  
Paterson, NJ 07505

Agenda: RESOLUTION AUTHORIZING AN AWARD OF CONTRACT TO BIG BELLY SOLAR, LLC TO RENEW SUPPORT SERVICES FOR PROPRIETARY SOFTWARE FOR THE COUNTY OF PASSAIC, PURSUANT TO N.J.S.A. 40A:11-3, ET SEQ. AND N.J.S.A. 40A:11-5(1)(dd), ALL AS NOTED IN THE RESOLUTION.

THIS RESOLUTION WAS REQUESTED BY:

RECYCLING

REVIEWED BY:

Anthony J. De Nova III  
COUNTY ADMINISTRATOR

APPROVED AS TO FORM AND LEGALITY:

Matthew P. Jordan, Esq.  
COUNTY COUNSEL

Health & Human Services

COMMITTEE NAME

<b>Official Resolution#</b>	<b>R20210734</b>							
Meeting Date	08/10/2021							
Introduced Date	08/10/2021							
Adopted Date	08/10/2021							
Agenda Item	I-18							
CAF #	G-01-41-761-018-213							
Purchase Req. #	R1-13786							
Result	Adopted							
<b>COMMISSIONER</b>	<b>PRES.</b>	<b>ABS.</b>	<b>MOVE</b>	<b>SEC</b>	<b>AYE</b>	<b>NAY</b>	<b>ABST.</b>	<b>RECU.</b>
Lepore	✓				✓			
James	✓		✓		✓			
Akhter	✓			✓	✓			
Bartlett	✓				✓			
Best Jr.	✓				✓			
Duffy	✓				✓			
Lazzara	✓				✓			

PRES.= present ABS.= absent  
 MOVE= moved SEC= seconded  
 AYE= yes NAY= no ABST.= abstain  
 RECU.= recuse

Dated: August 11, 2021

**RESOLUTION AUTHORIZING AN AWARD OF CONTRACT TO BIG BELLY SOLAR, LLC TO RENEW SUPPORT SERVICES FOR PROPRIETARY SOFTWARE FOR THE COUNTY OF PASSAIC, PURSUANT TO N.J.S.A. 40A:11-3, ET SEQ. AND N.J.S.A. 40A:11-5(1)(dd)**

**WHEREAS**, the County of Passaic (the “County”) is a government body incorporated pursuant to N.J.S.A. 40:18-1, et seq. and vested with all rights contained therein; and

**WHEREAS**, pursuant to N.J.S.A. 40:20-1 the Board of County Commissioners for the County of Passaic (hereinafter the “Board”) are vested with decision making powers on behalf of the County; and

**WHEREAS**, the Passaic County Department of Health, Division of Recycling and Natural Resources Division (hereafter “Division”) coordinates all solid waste and recycling planning functions on behalf of the County and its municipalities; and

**WHEREAS**, over the last five years the Division has procured solar powered Big Belly Solar, LLC garbage and recycling receptacles for placement within the Passaic County Park System and at various high-volume County facilities to promote recycling efforts, and by virtue of Resolution No. R20201083 dated December 8, 2020, the Board authorized an award of contract to purchase a subscription to the proprietary software operating said garbage receptacles; and

**WHEREAS**, Big Belly Solar, LLC garbage and recycling receptacles require support services for its proprietary software, as set forth in the renewal of the software agreement in an amount not to exceed nine thousand two hundred thirty-four dollars (\$9,234.00), attached to and made part of this resolution; and

**WHEREAS**, pursuant to N.J.S.A. 40A:11-5(1)(dd), any contract the amount of which exceeds the bid threshold for the provision or performance of goods or services for the support or maintenance of proprietary computer hardware and software, may be negotiated and awarded by the Board without public advertising for bids and bidding thereof; and

**WHEREAS**, Big Belly Solar, LLC executed and notarized the County’s Business Entity Disclosure Certification for non-fair and open contracts required pursuant to N.J.S.A. 19:44A-20.8, which is attached to and made part of this resolution; and

**WHEREAS**, funds are available in Account No. G-01-41-761-018-213 or any other account that may be deemed appropriate by the Chief Financial Officer or his designee, and the availability of funds has been contingently certified by the Chief Financial Officer subject to sufficient funds being appropriated by the Board in the 2021 and/or subsequent years’ County budget(s), which is attached to and made part of this Resolution; and

**WHEREAS**, this matter was discussed at the July 28, 2021 Health and Human Services Committee and is being recommended to the Board for approval; and

**NOW, THEREFORE, LET IT BE RESOLVED**, that pursuant to N.J.S.A. 40A:11-5(1)(dd) that the Board of Commissioners of the County of Passaic authorizes and approves the renewal of the software agreement with Big Belly Solar, LLC in an amount not to exceed nine thousand two hundred thirty-four dollars (\$9,234.00).

**LET IT BE FURTHER RESOLVED**, the Clerk of the Board shall print, in the official newspaper, a brief notice stating the nature, duration, service, and amount of the contract to the Big Belly Solar, LLC and maintain a copy of the resolution on file and available for public inspection in the Office of the Clerk to the Board.

**LET IT BE FURTHER RESOLVED**, that the Clerk of the Board, County Counsel, and the Director of the Board are authorized to take any other steps necessary to carry out the purpose of this Resolution.

KJB

August 10, 2021



July 22, 2021  
 Quota Number: Q18368-2  
 KS / JV

Prices valid for 60 days from above date.

**BIGBELLY CLEAN RENEWAL QUOTATION**

Prepared By:	Bill To:	Ship To:
Jason Vergados BigBelly Solar 150 A Street, Suite 103 Needham, MA 02494 (617) 431-1240 jvergados@bigbelly.com	Nina Selden County of Passaic 18 Clark Street Paterson, NJ 07505 (973) 305-5736 ninas@passaiccountynj.org	Darryl Sparta County of Passaic 209 Totowa Road Paterson, NJ 07470 (973) 872-6417 darryls@passaiccountynj.org

This order includes the following items:

QTY	SOFTWARE	TERM (months)	TERM Start Date	TERM End Date	UNIT PRICE	EXTENDED PRICE
30	Hub (HC or SC) Software - Renewal (Per Month) 1507500,1507501,1507502,1507503,1507504,1507505, 1507507,1507508,1507509,1507510,1507511,1507515, 1507516,1507517,1507518,1507519,1507520,1507521, 1507522,1507524,1507525,1507528,1507527,1507528, 1507529,1507575,1507584,1507585,1507586,1507587	12	07-27-2021	07-27-2022	\$14.25	\$5,130.00
32	Hub (HC or SC) Software - Renewal (Per Month) 1503542,1503543,1503544,1503545,1503546,1503547, 1503548,1503549,1503550,1503551,1503552,1503553, 1503554,1503555,1503556,1503557,1503558,1503559, 1503560,1503561,1503562,1503563,1503564,1503566, 1503568,1503571,1503572,1503573,1503574,1503576, 1503577,1503578	9	10-19-2021	07-19-2022	\$14.25	\$4,104.00

<b>Shipping &amp; Handling (one time):</b>	<b>\$0.00</b>
--	---------------

<b>Purchase Option</b>	<b>Total System Cost*:</b>	<b>\$9,234.00 USD</b>
------------------------	----------------------------	-----------------------

\* Total does not include applicable sales or use taxes.

Sincerely, Jason Vergados  
 Bigbelly Solar, LLC.

Wire Transfer Info: Middlesex Savings Bank. • Acct Name: Big Belly Solar LLC • Account # 166849558 • Routing # 2113712270 • Int'l Swift # MDSXUS3N

All Purchase Orders must reference the above Quota Number (upper right).

This Quotation is subject to the attached Terms and Conditions of Sale, which are attached hereto and incorporated herein, and expressly acknowledged and accepted by Customer as signified by the duly authorized signature below.

Introduced on: August 10, 2021  
 Adopted on: August 10, 2021  
 Official Resolution: R-2021-0754

www.bigbelly.com

T: 888-820-0300 • F: 781-444-5651



July 22, 2021  
Quote Number: Q10368-2  
KS / JV

<b>ACCEPTED AND AGREED BY:</b>	
<b>CUSTOMER</b>	
By: _____	Title _____
Print Name _____	Date _____

Introduced on: August 10, 2021  
Adopted on: August 10, 2021  
750 A St., Suite 103 - Needham, MA 02494  
Official Resolution#: R20210734

[www.bigbelly.com](http://www.bigbelly.com)

T: 888-820-0300 • F: 781-444-5651

COUNTY OF PASSAIC  
 HEALTH DEPT, CO OF PASSAIC  
 (Q) 973-881-4396  
 930 RIVERVIEW DRIVE - STE 250  
 TOTOWA, NJ 07512

REQUISITION	
NO.	R1-13786

SHIP TO	COUNTY OF PASSAIC HEALTH DEPARTMENT 930 RIVERVIEW DRIVE - STE 250 TOTOWA, NJ 07512
VENDOR	VENDOR #: 11599 BIG BELLY SOLAR, INC 150 A STREET, SUITE 103 NEEDHAM, MA 02494

ORDER DATE: 07/22/21  
 DELIVERY DATE:  
 STATE CONTRACT:  
 F.O.B. TERMS:

QTY/UNIT	DESCRIPTION	ACCOUNT NO.	UNIT PRICE	TOTAL COST
30.00	HUB (HC or SC Software-Renewal (Per Month) (12 Months) See Attached Quote	G-01-41-761-018-213	171.0000	5,130.00
32.00	HUB (HC or SC) Software renewal (Per Month) 9 Months)  See Attached Quote	G-01-41-761-018-213	128.2500	4,104.00
			TOTAL	9,234.00

Introduced on: August 10, 2021  
 Adopted on: August 10, 2021  
 Official Resolution#: R20210734

REQUESTING DEPARTMENT \_\_\_\_\_ DATE \_\_\_\_\_



CERTIFICATION OF AVAILABLE FUNDS

THIS IS TO CERTIFY THAT FUNDS ARE AVAILABLE AS FOLLOWS:

AMOUNT: \$9,234.00

APPROPRIATION: G-01-41-761-018-213

PURPOSE: Award contract to Big Belly Solar, LLC to renew support services for proprietary software.

  
\_\_\_\_\_

Richard Cahill, Director of Finance

DATED: August 10, 2021

# County of Passaic Board of County Commissioners

OFFICE OF COUNTY COMMISSIONERS

Director Pasquale "Pat" Lepore  
Deputy Director Bruce James  
Assad R. Akhter  
John W. Bartlett  
Theodore O. Best, Jr.  
Terry Duffy  
Cassandra "Sandi" Lazzara

401 Grand Street  
Paterson, New Jersey 07505  
Tel: 973-881-4402  
Fax: 973-742-3746

Anthony J. De Nova III  
*Administrator*  
Matthew P. Jordan, Esq.  
*County Counsel*  
Louis E. Imhof, III, RMC  
*Clerk Of The Board*



## Public Meeting (Board Meeting)

Date: Aug 10, 2021 - 5:30 PM

Location: County Administration Building  
Webex - 220  
401 Grand Street  
Paterson, NJ 07505

Agenda: RESOLUTION AUTHORIZING THE DEPARTMENT OF HEALTH TO APPLY FOR AND ACCEPT A GRANT FROM THE STATE OF NEW JERSEY, DEPARTMENT OF HEALTH FOR THE CHILDHOOD LEAD PROGRAM, PURSUANT TO N.J.S.A. 40:20-1 ET SEQ., ALL AS NOTED IN THE RESOLUTION., ALL AS NOTED IN THE RESOLUTION.

THIS RESOLUTION WAS REQUESTED BY:

HEALTH DEPT

REVIEWED BY:

  
Anthony J. De Nova III

COUNTY ADMINISTRATOR

APPROVED AS TO FORM AND LEGALITY:

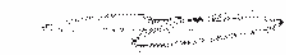
  
Matthew P. Jordan, Esq.

COUNTY COUNSEL

Health & Human Services

COMMITTEE NAME

<b>Official Resolution#</b>	<b>R20210735</b>							
Meeting Date	08/10/2021							
Introduced Date	08/10/2021							
Adopted Date	08/10/2021							
Agenda Item	I-19							
CAF #								
Purchase Req. #								
Result	Adopted							
<b>COMMISSIONER</b>	<b>PRES.</b>	<b>ABS.</b>	<b>MOVE</b>	<b>SEC</b>	<b>AYE</b>	<b>NAY</b>	<b>ABST.</b>	<b>RECU.</b>
Lepore	✓				✓			
James	✓		✓		✓			
Akhter	✓			✓	✓			
Bartlett	✓				✓			
Best Jr.	✓				✓			
Duffy	✓				✓			
Lazzara	✓				✓			

PRES.= present ABS.= absent  
 MOVE= moved SEC= seconded  
 AYE= yes NAY= no ABST.= abstain  
 RECU.= recuse

Dated: August 11, 2021

**RESOLUTION AUTHORIZING THE DEPARTMENT OF HEALTH TO APPLY FOR AND ACCEPT A GRANT FROM THE STATE OF NEW JERSEY, DEPARTMENT OF HEALTH FOR THE CHILDHOOD LEAD PROGRAM, PURSUANT TO N.J.S.A. 40:20-1 ET SEQ.**

**WHEREAS**, the County of Passaic (hereafter “County”) is a government body incorporated pursuant to N.J.S.A. 40:18-1, et seq. and vested with all rights contained therein; and

**WHEREAS**, pursuant to N.J.S.A. 40:20-1 the Board of County Commissioners for the County of Passaic are vested with decision making powers on behalf of the County; and

**WHEREAS**, the Department of Health (hereafter “Department”) is responsible for protecting and promoting the health of the approximately 510,000 residents of the County; and

**WHEREAS**, the State of New Jersey, Department of Health, has informed the Department that it is eligible for a grant award for the Childhood Lead Program Grant in the amount of two hundred twenty-nine thousand six hundred fourteen dollars (\$229,614.00) to be used in a one-year period beginning July 1, 2021 through June 30, 2022; and

**WHEREAS**, there exists a need to prevent harmful exposure to lead in children in the County, and the Childhood Lead Program provides resources to the County to discover lead contamination, and treat children exposed to lead; and

**WHEREAS**, there is no dollar match required to accept this award; and

**WHEREAS**, this matter was discussed at the July 28, 2021 meeting of the Health and Human Services Committee and being recommended to the Board for approval; and

**NOW, THEREFORE, LET IT BE RESOLVED**, the Board of County Commissioners of the County of Passaic, hereby authorizes the Department of Health to apply for and accept the grant award from the State of New Jersey, Department of Health, for the Childhood Lead Program Grant in the amount of two hundred twenty-nine thousand six hundred fourteen dollars (\$229,614.00) to be used in a one-year period beginning July 1, 2021 through June 30, 2022.

**LET IT BE FURTHER RESOLVED**, that the Director of the Board of County Commissioners for the County of Passaic, the County Counsel, and Clerk of the Board of County Commissioners are hereby authorized to take the necessary actions to accept the grant application authorized on behalf of the County of Passaic.

KJB

August 10, 2021



**State of New Jersey**  
**DEPARTMENT OF HEALTH**  
 PO BOX 361  
 TRENTON, N.J. 08625-0361

PHILIP D. MURPHY  
 Governor

SHEILA Y. OLIVER  
 Lt. Governor

[www.nj.gov/health](http://www.nj.gov/health)

JUDITH M. PERSICILLI, RN, BSN, MA  
 Commissioner

July 7<sup>th</sup>, 2021

Charlene Williams-Gungli  
 Health Officer  
 Passaic County Department of Health Services  
 401 Grand Street  
 Paterson, NJ 07605

Dear Ms. Gungli,

**SUBJECT: LETTER OF INTENT**

The New Jersey Department of Health, Office of Local Public Health intends to process your Grant application for the Childhood Lead Program in the approximate amount of **\$229,614**. The award is contingent upon the fully executed award signed by the Department's Approval Officer and the availability of funds. This award will be effective for the grant period 07/1/21 through 06/30/22.

You have submitted your grant during the competitive year of the FY 21-FY23 The Child Lead Program. For the next two years it will function as a 1-year renewal of a non-competitive grant. As such, the department will attempt to continue the base amount of funded granted in this year's application. Please consider this letter as notice of the Department's intent to funds in accordance with the legal provisions of such grant, and that the Notice of Grant Award document will be processed as soon as possible.

The Department will not be able to provide cash payments for any costs incurred by carrying out the items of this grant application until a fully executed Notice of Grant Award has been processed. Upon completion of this process, payment will be made in accordance with the grant provisions.

The Grantee recognizes and agrees that funding under a grant agreement is expressly dependent upon the availability of State and or Federal funds to the Department. The Department shall not be held liable for any breach of this agreement, resulting from the absence available funding appropriations.

Project Category	Funding Amount	Budget Period
Childhood Lead Program	\$229,614	07/1/21 – 6/30/22

The grant award will further be contingent upon the fiscal and programmatic completeness of your application, as well as the fulfillment of any current grant objectives, if applicable. **Grant applications are to be completed on-line via the System for Administering Grants Electronically (SAGE).** "Terms and Conditions" as well as Cost Controlling Initiatives will apply and may be found under "Management Activities" within each application. SAGE can be accessed at [nisage.intellicgrants.com](http://nisage.intellicgrants.com). Paper applications or amendments will not be accepted.

If you have any questions or need assistance, contact Dr. Siobhan Pappas, Program Management Officer at (609) 633-2937 or Mina Macar, Grants Management Officer at (609) 376-8764.

Introduced on: August 10, 2021  
 Adopted on: August 10, 2021  
 Official Resolution#: R20210735

Sincerely,



Shereen Sample, MS  
Director  
Office of Local Public Health

cc: SAGE Application  
Carl Michaels, Fiscal Management  
Dr. Siobhan Pappas, Program Management Officer  
Mina Macar, Grant Management Officer

# County of Passaic Board of County Commissioners

OFFICE OF COUNTY COMMISSIONERS

Director Pasquale "Pat" Lepore  
Deputy Director Bruce James  
Assad R. Akhter  
John W. Bartlett  
Theodore O. Best, Jr.  
Terry Duffy  
Cassandra "Sandi" Lazzara

401 Grand Street  
Paterson, New Jersey 07505

Tel: 973-881-4402  
Fax: 973-742-3746

Anthony J. De Nova III  
Administrator

Matthew P. Jordan, Esq.  
County Counsel

Louis E. Imhof, III, RMC  
Clerk Of The Board



## Public Meeting (Board Meeting)

Date: Aug 10, 2021 - 5:30 PM

Location: County Administration Building  
Webex - 220  
401 Grand Street  
Paterson, NJ 07505

Agenda: RESOLUTION AUTHORIZING AN AWARD OF CONTRACT TO THERMOFISHER SCIENTIFIC FOR LEAD ANALYZING EQUIPMENT, PURSUANT TO N.J.S.A. 40A:11-3, ET SEQ., ALL AS NOTED IN THE RESOLUTION.

THIS RESOLUTION WAS REQUESTED BY:

HEALTH DEPT

REVIEWED BY:

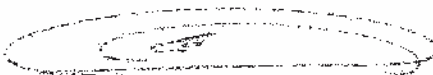
  
Anthony J. De Nova III

COUNTY ADMINISTRATOR

APPROVED AS TO FORM AND LEGALITY:

  
Matthew P. Jordan, Esq.

COUNTY COUNSEL

Health & Human Services

COMMITTEE NAME

<b>Official Resolution#</b>	<b>R20210736</b>							
Meeting Date	08/10/2021							
Introduced Date	08/10/2021							
Adopted Date	08/10/2021							
Agenda Item	I-20							
CAF #	1-01-27-180-001-219,							
Purchase Req. #	R1-13587							
Result	Adopted							
<b>COMMISSIONER</b>	<b>PRES.</b>	<b>ABS.</b>	<b>MOVE</b>	<b>SEC</b>	<b>AYE</b>	<b>NAY</b>	<b>ABST.</b>	<b>RECU.</b>
Lepore	✓				✓			
James	✓		✓		✓			
Akhter	✓			✓	✓			
Bartlett	✓				✓			
Best Jr.	✓				✓			
Duffy	✓				✓			
Lazzara	✓				✓			

PRES.= present ABS.= absent  
MOVE= moved SEC= seconded  
AYE= yes NAY= no ABST.= abstain  
RECU.= recuse

Dated: August 11, 2021

**RESOLUTION AUTHORIZING AN AWARD OF CONTRACT TO THERMOFISHER  
SCIENTIFIC FOR LEAD ANALYZING EQUIPMENT,  
PURSUANT TO N.J.S.A. 40A:11-3, ET SEQ.**

**WHEREAS**, the County of Passaic (the “County”) is a government body incorporated pursuant to N.J.S.A. 40:18-1, et seq. and vested with all rights contained therein; and

**WHEREAS**, pursuant to N.J.S.A. 40:20-1 the Board of County Commissioners for the County of Passaic (hereinafter the “Board”) are vested with decision making powers on behalf of the County; and

**WHEREAS**, pursuant to N.J.S.A. 40A:11-3(c), the Governor, in consultation with the Department of Treasury, shall, no later than March 1 of every fifth year beginning in the fifth year after the year in which P.L. 1999, c.440 takes effect, adjust the [bid] threshold amount, in direct proportion to the rise or fall of the index rate as the term is defined in section 2 of P.L. 1971, c. 198 (C.40A:11-2), and shall round the adjustment to the nearest \$1,000; and

**WHEREAS**, on June 30, 2020 the Board approved Resolution No. R20200514 setting the bid threshold at forty-four thousand dollars (\$44,000.00), in accordance with the law; and

**WHEREAS**, the Department of Health (hereafter “Department”) is responsible for protecting and promoting the health of the approximately 510,000 residents of the County; and

**WHEREAS**, there exists a need for lead analyzer equipment in connection with the Department’s Childhood Lead Exposure Program; and

**WHEREAS**, by virtue of Resolution No. R20210467 dated May 11, 2021, the Board awarded a non-fair and open contract to ThermoFisher Scientific in the amount of twenty-eight thousand three hundred seventy dollars (\$28,370.00) for the purchase of lead analyzing equipment for the administration of the Childhood Lead Exposure Prevention Program, after the department fielded quotes from known vendors; and

**WHEREAS**, the Department now desires to purchase from ThermoFisher Scientific a lead analyzer, and glucose test strips, in the total amount of two thousand six hundred thirty-eight dollars and eleven cents (\$2,638.11), such additional award being still below the aggregate bid threshold for awards of contract to ThermoFisher Scientific; and

**WHEREAS**, ThermoFisher Scientific has executed a Business Entity Disclosure Certification for Non-Fair and Open Contracts pursuant to N.J.S.A. 19:44A-20.8, stating that ThermoFisher Scientific has not made and will not make any reportable contributions pursuant to N.J.S.A. 19:44A-1, et seq. that would bar award of this contract, which is attached hereto and made part of this resolution; and

**WHEREAS**, the Health Officer is recommending the award of the non-fair and open contract to ThermoFisher Scientific, as a necessary expenditure for the administration of the Childhood Lead Exposure Prevention Program; and

**WHEREAS**, funds are available in Account No. 1-01-27-180-001-219, 1-01-27-180-221-245 or any other account that may be deemed appropriate by the Chief Financial Officer or his designee, and the availability of funds has been contingently certified by the Chief Financial Officer subject to sufficient funds being appropriated by the Board in the 2021 and/or subsequent years’ County budget(s), which is attached to and made part of this Resolution; and

**WHEREAS**, this matter was discussed at the July 28, 2021 meeting of the Health and Human Services Committee and being recommended to the Board of County Commissioners for the County of Passaic for approval; and

**NOW, THEREFORE, LET IT BE RESOLVED**, pursuant to N.J.S.A. 40A:11-3, et seq. the Passaic County Board of County Commissioners is awarding a non-fair and open contract to ThermoFisher Scientific in the amount of two thousand six hundred thirty-eight dollars and eleven cents (\$2,638.11) for the purchase of lead analyzing equipment for the administration of the Childhood Lead Exposure Prevention Program.

**LET IT BE FURTHER RESOLVED**, the Clerk of the Board shall print, in the official newspaper, a brief notice stating the nature, duration, service, and amount of the contract to ThermoFisher Scientific on file and available for public inspection in the Office of the Clerk to the Board.

**LET IT BE FURTHER RESOLVED**, that the Clerk of the Board, County Counsel, and Director of the Board of County Commissioners are authorized to execute the contract and take any other steps necessary to carry out the purpose of this resolution.

KJB

August 10, 2021



COUNTY OF PASSAIC  
 HEALTH DEPT, CO OF PASSAIC  
 (Q) 973-881-4396  
 930 RIVERVIEW DRIVE - STE 250  
 TOTOWA, NJ 07512

REQUISITION	
NO.	R1-13587

SHIP TO	COUNTY OF PASSAIC HEALTH DEPARTMENT 930 RIVERVIEW DRIVE - STE 250 TOTOWA, NJ 07512
VENDOR	VENDOR #: 00286 FISHER SCIENTIFIC COMPANY 3970 JOHNS CREEK COURT SUWANEE, GA 30024

ORDER DATE: 07/08/21  
 DELIVERY DATE:  
 STATE CONTRACT:  
 F.O.B. TERMS:

QTY/UNIT	DESCRIPTION	ACCOUNT NO.	UNIT PRICE	TOTAL COST
1.00 EA	Catalog #12 800 100 PMD 75.81 % 24.19 %	1-01-27-180-001-219 1-01-27-180-001-245	2,528.7400	2,528.74
1.00 EA	Leadcare II ANLZR/48 KT PR BX Vendor Catalog #227303 Catalog # 22 601 032	1-01-27-180-001-245	92.6700	92.67
1.00	Glucose 201 IND Civettes 50/PK Vendor Catalog # 110723	1-01-27-180-001-245	4.7000	4.70
1.00	Fuel Surcharge	1-01-27-180-001-245	12.0000	12.00
1.00	Integrity Packaging Fee Resolution #R02010467 5/11/21	1-01-27-180-001-245		
			TOTAL	2,638.11

*Need Approval*

Introduced on: August 10, 2021  
 Adopted on: August 10, 2021  
 Official Resolution#: R20210736

*Charlene W. Jung 7/9/21*  
 REQUESTING DEPARTMENT DATE

CERTIFICATION OF AVAILABLE FUNDS

THIS IS TO CERTIFY THAT FUNDS ARE AVAILABLE AS FOLLOWS:

AMOUNT: \$2,638.11

APPROPRIATION: 1-01-27-180-001-219 - \$1,917.09  
1-01-27-180-001-245 - \$721.02

PURPOSE: Award contract to ThermoFisher Scientific for lead analyzing equipment.

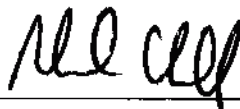

Richard Cahill, Director of Finance

DATED: August 10, 2021

# County of Passaic Board of County Commissioners

OFFICE OF COUNTY COMMISSIONERS

Director Pasquale "Pat" Lepore  
Deputy Director Bruce James  
Assad R. Akhter  
John W. Bartlett  
Theodore O. Best, Jr.  
Terry Duffy  
Cassandra "Sandi" Lazzara

401 Grand Street  
Paterson, New Jersey 07505

Tel: 973-881-4402  
Fax: 973-742-3746

Anthony J. De Nova III  
Administrator

Matthew P. Jordan, Esq.  
County Counsel

Louis E. Imhof, III, RMC  
Clerk Of The Board



## Public Meeting (Board Meeting)

Date: Aug 10, 2021 - 5:30 PM

Location: County Administration Building  
Webex - 220  
401 Grand Street  
Paterson, NJ 07505

Agenda: RESOLUTION AUTHORIZING THE PURCHASE OF COVID-19 INFORMATION PACKETS FOR DISTRIBUTION AT TESTING SITES FROM STEWART BUSINESS SYSTEMS, PURSUANT TO N.J.S.A. 40A:11-12, ET SEQ., ALL AS NOTED IN THE RESOLUTION.

THIS RESOLUTION WAS REQUESTED BY:

HEALTH DEPT

REVIEWED BY:

  
Anthony J. De Nova III

COUNTY ADMINISTRATOR

APPROVED AS TO FORM AND LEGALITY:

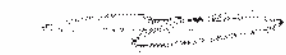
  
Matthew P. Jordan, Esq.

COUNTY COUNSEL

Health & Human Services

COMMITTEE NAME

<b>Official Resolution#</b>	<b>R20210737</b>							
Meeting Date	08/10/2021							
Introduced Date	08/10/2021							
Adopted Date	08/10/2021							
Agenda Item	I-21							
CAF #	G-01-41-962-020-PE1							
Purchase Req. #	R1-13702							
Result	Adopted							
<b>COMMISSIONER</b>	<b>PRES.</b>	<b>ABS.</b>	<b>MOVE</b>	<b>SEC</b>	<b>AYE</b>	<b>NAY</b>	<b>ABST.</b>	<b>RECU.</b>
Lepore	✓				✓			
James	✓		✓		✓			
Akhter	✓			✓	✓			
Bartlett	✓				✓			
Best Jr.	✓				✓			
Duffy	✓				✓			
Lazzara	✓				✓			

PRES.= present ABS.= absent  
 MOVE= moved SEC= seconded  
 AYE= yes NAY= no ABST.= abstain  
 RECU.= recuse

Dated: August 11, 2021

**RESOLUTION AUTHORIZING THE PURCHASE OF COVID-19 INFORMATION PACKETS FOR DISTRIBUTION AT TESTING SITES FROM STEWART BUSINESS SYSTEMS, PURSUANT TO N.J.S.A. 40A:11-12, ET SEQ.**

**WHEREAS**, the County of Passaic (the “County”) is a government body incorporated pursuant to N.J.S.A. 40:18-1, et seq. and vested with all rights contained therein; and

**WHEREAS**, pursuant to N.J.S.A. 40:20-1 the Board of County Commissioners for the County of Passaic (hereinafter the “Board”) are vested with decision making powers on behalf of the County; and

**WHEREAS**, the Department of Health (hereafter “Department”) is responsible for protecting and promoting the health of the approximately 510,000 residents of the County; and

**WHEREAS**, Coronavirus disease 2019 (hereafter “COVID-19”) is a contagious, and at times fatal, respiratory disease caused by the SARS-CoV-2 virus; and

**WHEREAS**, on March 9, 2020, New Jersey Governor Philip Murphy, in order to protect the health, safety, and welfare of the people of the State of New Jersey, signed Executive Order No. 103, declaring a Public Health Emergency and State of Emergency exist in the State of New Jersey; and

**WHEREAS**, pursuant to N.J.S.A. 40:11-12, the County may, without advertising for bids, or having rejected all bids obtained pursuant to advertising thereof, purchase any goods or services under any contract or contracts for such goods or services entered into on behalf of the State of New Jersey by the Division of Purchase and Property in the Department of Treasury; and

**WHEREAS**, Stewart Business Systems, of Burlington, New Jersey provided a quote for the purchase of COVID-19 information packets in an amount not to exceed eight thousand four hundred thirty-nine dollars and eighty-nine cents (\$8,439.89), attached to and made part of this resolution, which is being recommended for approval by the Director of the Health Department; and

**WHEREAS**, Stewart Business Systems submitted competitive pricing for G2075- Copiers & Multi-Function Devices, Maintenance, Supplies & Print Services, Master Blanket Purchase Order A40469, to the State of New Jersey, Division of Purchase and Property in the Department of Treasury; and

**WHEREAS**, funds are available in Account No. G-01-41-962-020-PE1 or any other account that may be deemed appropriate by the Chief Financial Officer or his designee, and the availability of funds has been contingently certified by the Chief Financial Officer subject to sufficient funds being appropriated by the Board in the 2021 and/or subsequent years’ County budget(s), which is attached to and made part of this Resolution; and

**WHEREAS**, this matter was discussed at the July 28, 2021 Health and Human Services Committee and is being recommended to the Board for approval; and

**NOW, THEREFORE, LET IT BE RESOLVED**, pursuant to N.J.S.A. 40:11-12, the Board of County Commissioners of the County of Passaic is authorizing the purchase of COVID-19 information packets from Stewart Business Group in an amount not to exceed eight thousand four hundred thirty-nine dollars and eighty-nine cents (\$8,439.89).

**LET IT BE FURTHER RESOLVED**, that the Clerk to the Board, County Counsel, and Purchasing Agent are authorized to execute an agreement and take any other steps necessary to carry out the purpose of this Resolution.

KJB

August 10, 2021



**CONTRACT INVOICE**

Invoice Number: IN994526  
 Invoice Date: 07/16/2021

**Bill To:** COUNTY OF PASSAIC HEALTH  
 930 RIVERVIEW DR  
 TOTAWA, NJ 07512  
 USA

**Customer:** COUNTY OF PASSAIC HEALTH  
 930 RIVERVIEW DR  
 TOTAWA, NJ 07512

Account No	Payment Terms	Due Date	Invoice Total	Balance Due	
CO31:154915-W	Customer Net 30	08/15/2021	\$8,439.89	\$8,439.89	
Invoice Remarks					
Contract Number	Contract	Contract Amount	P.O. Number	Start Date	Exp. Date
W-CN6469-01	973-881-4396	\$8,439.89	19-001839	07/16/2015	
Contract Remarks					
***ALL USAGE IS CPC***					

**Summary:**

Contract base rate charge for this billing period	\$0.00 *
Contract coverage charge for the 04/16/2021 to 07/15/2021 coverage period	\$8,439.89 **
*Sum of equipment base charges **See coverage details below	\$8,439.89

**Details:**

**Equipment included under this contract**

**XBR/XWC7845**

Number	Serial Number	Base Charge	Location
N5264-W	9X4751022	\$0.00	COUNTY OF PASSAIC HEALTH 930 RIVERVIEW DR TOTAWA, NJ 07512 MAIN FLR

Meter Type	Meter Group	Begin Meter	End Meter	Credits	Total	Covered	Bilable #	Rate	Overage
BK	CN6469-01-6135-1	345,008	385,308		40,300	0	40,300	\$0.011450	\$461.44
CLR	CN6469-01-6138-1	594,154	663,847		69,693	0	69,693	\$0.114486	\$7,978.45
									<b>\$8,439.89</b>

Please Remit Payments to:

Stewart Business Systems, LLC

PO Box 936763

Atlanta, GA 31193-6763

(800) 322-5584

Invoice SubTotal	\$8,439.89
Tax	\$0.00
Invoice Total	\$8,439.89
Balance Due	<b>\$8,439.89</b>

Introduced on: August 10, 2021  
 Adopted on: August 10, 2021  
 Official Resolution#: R20210737

**COUNTY OF PASSAIC**  
 HEALTH DEPT, CO OF PASSAIC  
 (Q) 973-881-4396  
 930 RIVERVIEW DRIVE - STE 250  
 TOTOWA, NJ 07512

REQUISITION	
NO.	R1-13702

S H I P  T O	COUNTY OF PASSAIC HEALTH DEPARTMENT 930 RIVERVIEW DRIVE - STE 250 TOTOWA, NJ 07512
V E N D O R	VENDOR #: 10000 STEWART BUSINESS SYSTEMS 105 CONNECTICUT DRIVE BURLINGTON TWP, NJ 08016

ORDER DATE: 07/19/21  
 DELIVERY DATE:  
 STATE CONTRACT: A40469  
 F.O.B. TERMS:

QTY/UNIT	DESCRIPTION	ACCOUNT NO.	UNIT PRICE	TOTAL COST
1.00	Contract #W-CN6469-01 Invoice #IN994526 7/16/21  Price as per State Contract  Res. #R20210500 5/25/21  For use in making packets of COVID information for vaccination sites.	G-01-41-962-020-PE1	8,439.8900	8,439.89
			TOTAL	8,439.89

Introduced on: August 10, 2021  
 Adopted on: August 10, 2021  
 Official Resolution#: R20210737

\_\_\_\_\_  
 REQUESTING DEPARTMENT DATE

CERTIFICATION OF AVAILABLE FUNDS

THIS IS TO CERTIFY THAT FUNDS ARE AVAILABLE AS FOLLOWS:

AMOUNT: \$8,439.89

APPROPRIATION: G-01-41-962-020-PE1

PURPOSE: Authorizing purchase of COVID-19 information packets for distribution at testing sites.



Richard Cahill, Director of Finance

DATED: August 10, 2021

# County of Passaic Board of County Commissioners

OFFICE OF COUNTY COMMISSIONERS

Director Pasquale "Pat" Lepore  
Deputy Director Bruce James  
Assad R. Akhter  
John W. Bartlett  
Theodore O. Best, Jr.  
Terry Duffy  
Cassandra "Sandi" Lazzara

401 Grand Street  
Paterson, New Jersey 07505  
Tel: 973-881-4402  
Fax: 973-742-3746

Anthony J. De Nova III  
*Administrator*  
Matthew P. Jordan, Esq.  
*County Counsel*  
Louis E. Imhof, III, RMC  
*Clerk Of The Board*



## Public Meeting (Board Meeting)

Date: Aug 10, 2021 - 5:30 PM

Location: County Administration Building  
Webex - 220  
401 Grand Street  
Paterson, NJ 07505

Agenda: RESOLUTION AUTHORIZING AN AWARD OF CONTRACT TO FC CARES, INC., TO PROVIDE MENTAL HEALTH CRISIS INTERVENTION CONSULTANT SERVICES AND RISK ASSESSMENT INSTRUCTION FOR PASSAIC COUNTY SCHOOLS, PURSUANT TO N.J.S.A. 40A:11-6.1(a), ALL AS NOTED IN THE RESOLUTION.

THIS RESOLUTION WAS REQUESTED BY:

HUMAN SERVICES

REVIEWED BY:

  
Anthony J. De Nova III

COUNTY ADMINISTRATOR

APPROVED AS TO FORM AND LEGALITY:

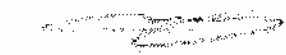
  
Matthew P. Jordan, Esq.

COUNTY COUNSEL

Health & Human Services

COMMITTEE NAME

<b>Official Resolution#</b>	<b>R20210738</b>							
Meeting Date	08/10/2021							
Introduced Date	08/10/2021							
Adopted Date	08/10/2021							
Agenda Item	I-22							
CAF #	1-01-27-162-002-213							
Purchase Req. #	R1-13772							
Result	Adopted							
<b>COMMISSIONER</b>	<b>PRES.</b>	<b>ABS.</b>	<b>MOVE</b>	<b>SEC</b>	<b>AYE</b>	<b>NAY</b>	<b>ABST.</b>	<b>RECU.</b>
Lepore	✓				✓			
James	✓		✓		✓			
Akhter	✓			✓	✓			
Bartlett	✓				✓			
Best Jr.	✓				✓			
Duffy	✓				✓			
Lazzara	✓				✓			

PRES.= present ABS.= absent  
MOVE= moved SEC= seconded  
AYE= yes NAY= no ABST.= abstain  
RECU.= recuse

Dated: August 11, 2021



**RESOLUTION AUTHORIZING AN AWARD OF CONTRACT TO FC CARES, INC., TO PROVIDE MENTAL HEALTH CRISIS INTERVENTION CONSULTANT SERVICES AND RISK ASSESSMENT INSTRUCTION FOR PASSAIC COUNTY SCHOOLS, PURSUANT TO N.J.S.A. 40A:11-6.1(a)**

**WHEREAS**, the County of Passaic (the "County") is a government body incorporated pursuant to N.J.S.A. 40:18-1, et seq. and vested with all rights contained therein; and

**WHEREAS**, pursuant to N.J.S.A. 40:20-1 the Board of County Commissioners for the County of Passaic (hereinafter the "Board") are vested with decision making powers on behalf of the County; and

**WHEREAS**, the Department of Human Services (hereafter "Department") is an umbrella social service agency concerned with planning and funding services for the County's disadvantaged and homeless citizens; and

**WHEREAS**, the Department desires to provide instruction to Passaic County schools, staff, and families regarding how to intervene and care for individuals suffering from mental health crises; and

**WHEREAS**, pursuant to N.J.S.A. 40A:11-6.1(a), the Department solicited three quotes from local vendors to operate a juvenile delinquency prevention program; and

**WHEREAS**, the Department desires to award a contract to FC Cares, Inc., to provide consultant services and instruction to Passaic County schools, staff, and families for mental health crisis intervention and risk assessment in an amount not to exceed eight thousand seven hundred fifty dollars (\$8,750.00) for a contract period beginning July 1, 2021, through December 31, 2021; and

**WHEREAS**, funds are available in Account No. 1-01-27-162-002-213 or any other account that may be deemed appropriate by the Chief Financial Officer or his designee, and the availability of funds has been contingently certified by the Chief Financial Officer subject to sufficient funds being appropriated by the Board in the 2021 and/or subsequent years' County budget(s), which is attached to and made part of this Resolution; and

**WHEREAS**, this matter was discussed at the July 28, 2021 Health and Human Services Committee and is being recommended to the Board for approval; and

**NOW, THEREFORE, LET IT BE RESOLVED**, pursuant to N.J.S.A. 40A:11-6.1(a), the Board of County Commissioners of the County of Passaic authorizes an award of contract to FC Cares, Inc., to provide consultant services and instruction to Passaic County schools, staff, and families for mental health crisis intervention and risk assessment in an amount not to exceed eight thousand seven hundred fifty dollars (\$8,750.00) for a contract period beginning July 1, 2021, through December 31, 2021.

**LET IT BE FURTHER RESOLVED**, that the Clerk of the Board, County Counsel, and the Director of the Board of County Commissioners are authorized to take any other steps necessary to carry out the purpose of this resolution.

KJB

August 10, 2021

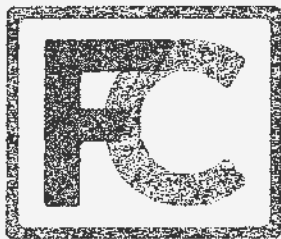

# CARES INC.

Mr. Steven Fiedeldey

[Fiedeldey.Steven@gmail.com](mailto:Fiedeldey.Steven@gmail.com)

(P) 201.669.7495

**1. *Description of the Applicant, Qualifications and Experience in Providing Proposed Services:***

FC Cares Inc. was formed in response to the ongoing and increasing mental health crisis facing today's youth. Suicide rates have increased by almost 60% among New Jersey's youth aged 15 to 24. Mr. Steven Fiedeldey, has been employed by the Ringwood Public Schools for the past 11 years, first as a school psychologist and then as the Director of Special Services. Mr. Fiedeldey has obtained a BA in psychology, MA in Educational Psychology, MA in Educational Leadership, while also holding certificates from the New Jersey Department of Education as School Psychologist and Principal. Mr. Fiedeldey is also currently enrolled at the International Institute for Restorative Practices to obtain his MA in Restorative Practices. FC Cares Inc. was formed at the encouragement of Mr. Fiedeldey's superintendent of schools with the primary purpose of helping to support neighboring towns' target population of students, staff, and families struggling with our mental health crisis.

As the Director of Special Services for the Ringwood Public Schools, Mr. Fiedeldey has spearheaded his department's growth, development, and adaptation of comprehensive and robust crisis intervention procedures. These procedures include the adoption and adaptation of evidence-based instruments to screen for suicidality, non-suicidal self-injurious behavior, and threat to others. More recently, Mr. Fiedeldey initiated a universal screening for depression for middle school students. Those students then receive school-based therapy to help alleviate the symptoms of depression interfering with their ability to access their education. All students reported decreased symptoms of depression during this intervention. Mr. Fiedeldey has conducted workshops and trainings on these initiatives and others for Passaic County schools, neighboring counties, and at state level conferences. Given his dedication to the social-emotional well-being of our youth for his entire career and proven results, it is anticipated that FC Cares Inc., will provide exceptional services and a continuum of professional learning for others within Passaic County to help fight our mental health crisis which has only been exacerbated by COVID-19.

**2. *Existing and Proposed Relationships with other Agencies and Individuals***

FC Cares Inc's board members are Steven Fiedeldey, Sarah Fiedeldey, and Victoria Trbuhovich. Steven is employed full-time by the Ringwood Public Schools and Montclair State University where he serves as an adjunct professor. Sarah Fiedeldey works for Gravity Goldberg LLC as a literacy consultant. Victoria Trbuhovich is a retired teacher.

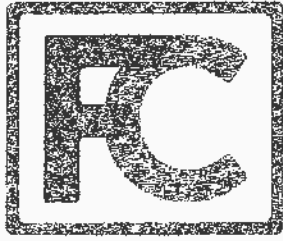

# CARES INC.

Mr. Steven Fiedeldey

[Fiedeldey.Steven@gmail.com](mailto:Fiedeldey.Steven@gmail.com)

(P) 201.669.7495

**3. Target population and Communities to Be Served:**

The target population and communities to be served may include students, families, and educators within Passaic County.

**4. Existing Need Indicators for the Proposed Service:**

Research and reporting from the Center for Disease control is clear that as a nation we are facing increased deaths by suicide of which many suffer from mental health conditions. In 2016, we lost nearly 45,000 individual to suicide. Along with increase rates of suicide, the National Institute of Mental Health reports rates of anxiety and depression increasing. Currently both the New Jersey State Assembly and Senate have approved legislation that would mandate universal depression screening for students in grades 7 – 12.

**5. Description of Project:**

The overview of the project Addressing Our Mental Health Crisis, is to offer professional consulting services to Passaic County schools, staff, and families. These services will be individualized to meet the need of the school district and may include professional learning around crisis intervention / risk assessment, social-emotional learning, restorative practices, universal screening for depression, suicide gatekeeper training, and other mental health related issues. The specific methodologies and approaches are all evidence-based interventions. For example crisis intervention / risk assessment interventions rely on the Columbia Suicide Severity Rating Scale, Non-Suicidal Self-Injury Assessment Tool (NSSI-AT), Functional Assessment of Self-Mutilation (FASM), and the Virginia Student Threat Assessment Guidelines. The screening for depression utilizes the Columbia DISC Depression Scale, while the suicide gatekeeper training is Question, Persuade, Refer (QPR). In working with the Passaic County schools, FC Cares Inc. will not maintain any client records. All student records will be maintained by the local education agency (LEA), and it is their responsibility to ensure that they are FERPA compliant.

Training will occur during the 2021-22 school year at times identified by local education agencies. The goal is for the targeted population of students, families and/or staff connected with Passaic County schools to increase their professional knowledge / skills through quality training / professional learning on social-emotional issues that may include mental health, suicide gatekeeper training, depression screening, crisis intervention, and/or risk assessments during the 2021-22 school year.

**6. Facilities/Equipment:**

All professional learning will take place at the facilities of Passaic County schools or virtually.

**7. Staffing:**

Staffing for the work outlined in this grant will all be completed by Mr. Steven Fiedeldey.

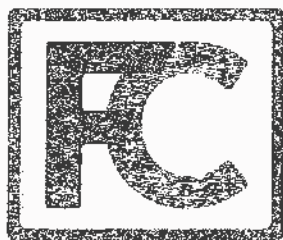

# CARES INC.

---

Mr. Steven Fiedeldey

[Fiedeldey.Steven@gmail.com](mailto:Fiedeldey.Steven@gmail.com)

(P) 201.669.7495

**8. Evaluation:**

FC Cares Inc. will distribute program evaluation forms at the conclusion of each day of training during the 2021-22 school year. The measureable outcomes will evaluate the effectiveness of intervention outlined by the following outcomes:

- (1) For each day of training, 70% of the population receiving training or participating in professional learning will experience an increase in professional knowledge as indicated on the participant completed program evaluation form.
- (2) For each day a unique population is trained, 75% of participants will rate the training and/or professional learning 3 out of 5 as indicated on the participant completed program evaluation form.
- (3) For each day of training, 80% of targeted population will participate in the professional learning experience.

**9. Budget Requirements**

The budgeting requirements as outlined in Annex B, requires a daily consulting fee of \$2,300 per day along with \$200 of supplies for day. This would total \$16,100 in consulting fees and \$1,400 in supplies. This rate is in keeping with the professional norms of other quotes for consulting work in schools that reach \$3500 per day.

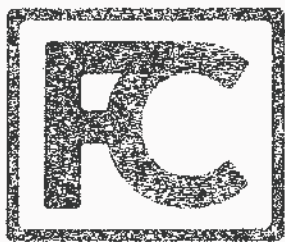

# CARES INC.

Mr. Steven Fiedeldey

[Fiedeldey.Steven@gmail.com](mailto:Fiedeldey.Steven@gmail.com)

(P) 201.669.7495

May 30, 2021

To Whom It May Concern:

Our country is facing a national mental health epidemic. FC Cares Inc. hopes to provide the desperately needed expertise and partnership for schools to be proactive in supporting the social-emotional well-being of their students.

#### **Universal Screening for Depression:**

FC Cares Inc. will share years of experience to help expedite and navigate and educate districts regarding the process of universal screening for depression. We will collaborate with district staff and develop a personalized standard operating procedure. We share our experiences and best practices in the actual deployment of the depression screener and next steps for on-going school-based counseling. Our goal is to form a partnership with Passaic County school districts through every step of this critical process.

#### **Crisis Intervention / Risk Assessment Protocols and Procedures:**

Another service offered with these monies is professional learning centered around crisis intervention / risk assessment protocols and procedures. When it comes to students making comments about wanting to hurt themselves or others, staff deserve the training and protection of utilizing evidence-based instruments to make their decisions. FC Cares Inc. will work with districts to develop customized standard operating procedures for staff to screen students who may pose a threat to themselves or others. Upon completing this training, staff are able to confidently assign a risk level to a student in need and respond in a measured and appropriate way. A lack of systems and structures results in school staff erring on the side of caution, which often puts an excess number of students through the financial and emotional burden of unnecessarily being medically cleared to return to school. The adoption of a comprehensive package of evidence-based risk assessment instruments and standardized procedures results in districts maximizing resources, while acting from a position of legally defensible best practices to support student mental health.

#### **Suicide Prevention:**

Staff will be trained in identifying early signs of suicide, ways to offer hope, and how to compassionately persuade them to seek appropriate help. When it comes to suicide prevention training you might ask who should be trained? Teachers. Students. Parents. Paraprofessionals. Administrators. Bus Drivers. Custodians. Cafeteria staff. Anyone. EVERYONE. The warning

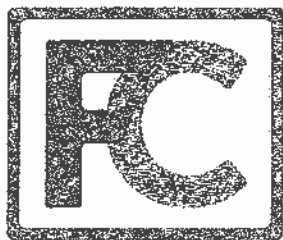

# CARES INC.

---

Mr. Steven Fiedeldey

[Fiedeldey.Steven@gmail.com](mailto:Fiedeldey.Steven@gmail.com)

(P) 201.669.7495

signs of depression, hopelessness, or talk of suicide can occur anywhere at any time. The more people in your community that are trained the greater chance of intervening and saving a life.

Thank you for your consideration in awarding this money to support the staff, students, and families of Passaic County.

COUNTY OF PASSAIC  
 HUMAN SERVICES, CO OF PASSAIC  
 (Q) 973-881-2834  
 401 GRAND ST. ROOM 506  
 PATERSON, NJ 07505

REQUISITION	
NO.	R1-13772

S H I P T O	COUNTY OF PASSAIC-HUMAN SERV HUMAN SERVICES 401 GRAND ST. ROOM 506 PATERSON, NJ 07505
V E N D O R	VENDOR #: 13484 FC CARES INC. ATTN: STEVEN FIEDELDEY 10 MORTON PLACE OAKLAND, NJ 07436

ORDER DATE: 07/21/21  
 DELIVERY DATE:  
 STATE CONTRACT:  
 F.O.B. TERMS:

QTY/UNIT	DESCRIPTION	ACCOUNT NO.	UNIT PRICE	TOTAL COST
1.00	MENTAL HEALTH CRISIS ONLY TO BE PAID IN PARTIAL PAYMENTS  GRANT: PC MENTAL HEALTH  CONTRACT PERIOD: 7/1/2021-12/31/2021  AMOUNT: \$17,500  MENTAL HEALTH AWARD TO FC CARES TO PROVIDE MENTAL HEALTH, CRISIS INTERVENTION, ETC. TO PASSAIC COUNTY SCHOOLS AND FAMILIES.	1-01-27-162-002-213	8,750.0000	8,750.00
			TOTAL	8,750.00

REQUESTING DEPARTMENT

DATE

Introduced on: August 10, 2021  
 Adopted on: August 10, 2021  
 Official Resolution#: R20210738

CERTIFICATION OF AVAILABLE FUNDS

THIS IS TO CERTIFY THAT FUNDS ARE AVAILABLE AS FOLLOWS:

AMOUNT: \$8,750.00

APPROPRIATION: 1-01-27-162-002-213

PURPOSE: Award contract to FC Cares, Inc. to provide mental health crisis intervention consultant services and risk assessment instruction.

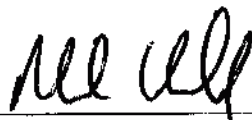

Richard Cahill, Director of Finance

DATED: August 10, 2021



# County of Passaic Board of County Commissioners

OFFICE OF COUNTY COMMISSIONERS

Director Pasquale "Pat" Lepore  
Deputy Director Bruce James  
Assad R. Akhter  
John W. Bartlett  
Theodore O. Best, Jr.  
Terry Duffy  
Cassandra "Sandi" Lazzara

401 Grand Street  
Paterson, New Jersey 07505  
Tel: 973-881-4402  
Fax: 973-742-3746

Anthony J. De Nova III  
*Administrator*  
Matthew P. Jordan, Esq.  
*County Counsel*  
Louis E. Imhof, III, RMC  
*Clerk Of The Board*



## Public Meeting (Board Meeting)

Date: Aug 10, 2021 - 5:30 PM

Location: County Administration Building  
Webex - 220  
401 Grand Street  
Paterson, NJ 07505

Agenda: RESOLUTION AUTHORIZING THE PASSAIC COUNTY DEPARTMENT OF HUMAN SERVICES TO APPLY FOR AND ACCEPT A GRANT FROM THE STATE OF NEW JERSEY, DEPARTMENT OF LAW AND PUBLIC SAFETY, JUVENILE JUSTICE COMMISSION UNDER THE JUVENILE DETENTION ALTERNATIVES INITIATIVE INNOVATION FUNDING GRANT, PURSUANT TO N.J.S.A. 40:20-1, ET SEQ., ALL AS NOTED IN THE RESOLUTION.

THIS RESOLUTION WAS REQUESTED BY:

HUMAN SERVICES

REVIEWED BY:

Anthony J. De Nova III  
COUNTY ADMINISTRATOR

APPROVED AS TO FORM AND LEGALITY:

Matthew P. Jordan, Esq.  
COUNTY COUNSEL

Health & Human Services  
COMMITTEE NAME

<b>Official Resolution#</b>	<b>R20210739</b>							
Meeting Date	08/10/2021							
Introduced Date	08/10/2021							
Adopted Date	08/10/2021							
Agenda Item	I-23							
CAF #								
Purchase Req. #								
Result	Adopted							
<b>COMMISSIONER</b>	<b>PRES.</b>	<b>ABS.</b>	<b>MOVE</b>	<b>SEC</b>	<b>AYE</b>	<b>NAY</b>	<b>ABST.</b>	<b>RECU.</b>
Lepore	✓				✓			
James	✓		✓		✓			
Akhter	✓			✓	✓			
Bartlett	✓				✓			
Best Jr.	✓				✓			
Duffy	✓				✓			
Lazzara	✓				✓			

PRES.= present ABS.= absent  
 MOVE= moved SEC= seconded  
 AYE= yes NAY= no ABST.= abstain  
 RECU.= recuse

Dated: August 11, 2021

**RESOLUTION AUTHORIZING THE PASSAIC COUNTY DEPARTMENT OF HUMAN SERVICES TO APPLY FOR AND ACCEPT A GRANT FROM THE STATE OF NEW JERSEY, DEPARTMENT OF LAW AND PUBLIC SAFETY, JUVENILE JUSTICE COMMISSION UNDER THE JUVENILE DETENTION ALTERNATIVES INITIATIVE INNOVATION FUNDING GRANT, PURSUANT TO N.J.S.A. 40:20-1, ET SEQ.**

**WHEREAS**, the County of Passaic (hereafter "County") is a government body incorporated pursuant to N.J.S.A. 40:18-1, et seq. and vested with all rights contained therein; and

**WHEREAS**, pursuant to N.J.S.A. 40:20-1 the Board of County Commissioners for the County of Passaic (hereafter "Board") are vested with decision making powers on behalf of the County; and

**WHEREAS**, the Passaic County Department of Human Services (hereafter "Department") is an umbrella social service agency concerned with planning and funding services for disadvantaged and homeless citizens; and

**WHEREAS**, in a letter dated June 25, 2021, the State of New Jersey, Department of Law and Public Safety, Juvenile Justice Commission, informed the County that it is eligible to apply for and accept the 2022 Juvenile Detention Alternatives Initiative Innovations Funding Grant, Sub-award number JDAI-22-IF-16 in the amount of one hundred twenty thousand dollars (\$120,000.00), for the sub-award period beginning on January 1, 2022, through December 31, 2022, such letter attached hereto and made a part of this resolution herein; and

**WHEREAS**, the Department desires to accept the 2022 Juvenile Detention Alternatives Initiative Innovations Funding Grant in order to develop innovative programs as an alternative to juvenile detention; and

**WHEREAS**, there is no dollar match required to accept this award; and

**WHEREAS**, this matter was discussed for the July 28, 2021 meeting of Health and Human Services Committee and is being recommended to the Board for approval;

**NOW, THEREFORE, LET IT BE RESOLVED**, that pursuant to N.J.S.A. 40:20-1 et seq. the Board of County Commissioners of the County of Passaic hereby authorizes the Passaic County Department of Human Services to apply for the 2022 Juvenile Detention Alternatives Initiative Innovations Funding Grant, Sub-award number JDAI-22-IF-16, from the State of New Jersey, Department of Law and Public Safety, Juvenile Justice Commission, in the amount of one hundred twenty thousand dollars (\$120,000.00) for the grant period beginning January 1, 2022, through December 31, 2022.

**LET IT BE FURTHER RESOLVED**, that pursuant to N.J.S.A. 40:20-1 et seq., the Board of County Commissioners of the County of Passaic hereby declares that the Passaic County Department of Human Services is authorized to accept the 2022 Juvenile Detention Alternatives Initiative Innovations Funding Grant, Sub-award number JDAI-22-IF-16, in the amount of one hundred twenty thousand dollars (\$120,000.00) for the grant period beginning January 1, 2022, through December 31, 2022.

**LET IT BE FURTHER RESOLVED**, that the Clerk of the Board, County Counsel, the Director of the Department of Human Services, and the Director of the Board of County Commissioners of the County of Passaic are authorized to take any other steps necessary to carry out the purpose of this resolution.

KJB

August 10, 2021



State of New Jersey  
Office of the Attorney General  
DEPARTMENT OF LAW AND PUBLIC SAFETY  
Juvenile Justice Commission  
P.O. Box 107  
Trenton, New Jersey 08625-0107

Philip D. Murphy  
Governor

Sheila Y. Oliver  
Lt. Governor

Gurbir S. Grewal  
Attorney General

Jennifer LeBaron, Ph.D.  
Acting Executive Director

June 25, 2021

Le'Var Starr  
Jenny Vuksic  
Passaic County Youth Services Commission  
401 Grand Street, Room 417  
Paterson, NJ 07505

Re: CY 2022 Innovations Funding Eligibility

Dear Mr. Starr & Ms. Vuksic:

I am pleased to inform you that Passaic County is eligible for Innovations Funding for the period January 1, 2022 to December 31, 2022 in the amount of \$120,000. This figure is to be used for planning purposes and is subject to appropriation and availability of sufficient funds.

You must submit your application to the Juvenile Justice Commission on behalf of the County Council on Juvenile Justice System Improvement by 3:00 pm on August 6, 2021. Applications are to be submitted via email to [JCYSCGrants@jjc.nj.gov](mailto:JCYSCGrants@jjc.nj.gov).

Your County Council should proceed with collaboratively preparing the Innovations Application. Since JDAI is a data-driven process, in planning for the funding the County Council should be sure to examine data regarding the local detention system to determine which core strategy area(s) to address. In addition to ideas outlined in the Innovations Funding packet previously distributed, sites are encouraged to consult available resources, such as the *Pathways to Juvenile Detention Reform* series and the JDAI Connect (<https://community.aecf.org/community/jdai-connect>) for innovative approaches to system improvement in those identified core strategy areas.

For your information, I have attached a copy of the Innovations Funding Eligibility letter sent to the County Council Co-Chairs. If you have any questions about this process, please call Safiya L. Baker (609) 341-3632.



Introduced: August 10, 2021  
Adopted on: August 10, 2021  
Official Resolution#: R20210739

REALIZING POTENTIAL & CHANGING FUTURES  
New Jersey Is An Equal Opportunity Employer  
Printed on Recycled Paper and Recyclable



Jenny Vuksic & Le'Var Starr  
June 25, 2021  
Page 2 of 2

Thank you for your cooperation in the implementation of Innovations Funding. I look forward to continuing to work with you, the Passaic County Youth Services Commission and the Passaic County Council on Juvenile Justice System Improvement.

Sincerely,

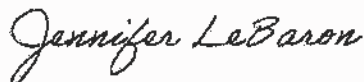

Jennifer LeBaron, Ph.D.  
Acting Executive Director

JL/slb

- c: Hon. Rudolph Filko, Co-Chair, County Council
- Melanie Nowling, Co-Chair, County Council
- Doris S. Darling, Director, Office of Local Programs & Services, JJC
- Paul Sumners, Chief of Budget & Finance, JJC
- Safiya L. Baker, Manager, YSC Grants Management Unit, JJC
- Joelle Kenney, Manager, JDAI System & Reform Unit, JJC
- Miguel Williams, Research & Reform Specialist, JJC
- Troy Alexander, JDAI Management Representative, JJC

# County of Passaic Board of County Commissioners

OFFICE OF COUNTY COMMISSIONERS

Director Pasquale "Pat" Lepore  
Deputy Director Bruce James  
Assad R. Akhter  
John W. Bartlett  
Theodore O. Best, Jr.  
Terry Duffy  
Cassandra "Sandi" Lazzara

401 Grand Street  
Paterson, New Jersey 07505  
Tel: 973-881-4402  
Fax: 973-742-3746

Anthony J. De Nova III  
*Administrator*  
Matthew P. Jordan, Esq.  
*County Counsel*  
Louis E. Imhof, III, RMC  
*Clerk Of The Board*



## Public Meeting (Board Meeting)

Date: Aug 10, 2021 - 5:30 PM

Location: County Administration Building  
Webex - 220  
401 Grand Street  
Paterson, NJ 07505

Agenda: RESOLUTION INCREASING APPROPRIATION AND APPROVING A FOUR MONTH INCREASE IN CONTRACT TERM TO THE VARIOUS VENDORS UNDER SB-20-035, TO BE USED ON AN AS-NEEDED BASIS BY PREAKNESS HEALTHCARE CENTER FOR MEDICAL AND DENTAL SUPPLIES, PURSUANT TO N.J.S.A. 40A:11-15, ALL AS NOTED IN THE RESOLUTION.

THIS RESOLUTION WAS REQUESTED BY:

PREAKNESS HC

REVIEWED BY:

Anthony J. De Nova III

COUNTY ADMINISTRATOR

APPROVED AS TO FORM AND LEGALITY:

Matthew P. Jordan, Esq.

COUNTY COUNSEL

Health & Human Services

COMMITTEE NAME

<b>Official Resolution#</b>	<b>R20210740</b>							
Meeting Date	08/10/2021							
Introduced Date	08/10/2021							
Adopted Date	08/10/2021							
Agenda Item	I-24							
CAF #	1-01-27-172-001-M01							
Purchase Req. #	R1-13540							
Result	Adopted							
<b>COMMISSIONER</b>	<b>PRES.</b>	<b>ABS.</b>	<b>MOVE</b>	<b>SEC</b>	<b>AYE</b>	<b>NAY</b>	<b>ABST.</b>	<b>RECU.</b>
Lepore	✓				✓			
James	✓		✓		✓			
Akhter	✓			✓	✓			
Bartlett	✓				✓			
Best Jr.	✓				✓			
Duffy	✓				✓			
Lazzara	✓				✓			

PRES.= present ABS.= absent  
MOVE= moved SEC= seconded  
AYE= yes NAY= no ABST.= abstain  
RECU.= recuse

Dated: August 11, 2021

**RESOLUTION INCREASING APPROPRIATION AND APPROVING A FOUR MONTH INCREASE IN CONTRACT TERM TO THE VARIOUS VENDORS UNDER SB-20-035, TO BE USED ON AN AS-NEEDED BASIS BY PREAKNESS HEALTHCARE CENTER FOR MEDICAL AND DENTAL SUPPLIES, PURSUANT TO N.J.S.A. 40A:11-15**

**WHEREAS**, the County of Passaic (hereafter "County") is a government body incorporated pursuant to N.J.S.A. 40:18-1, et seq. and vested with all rights contained therein; and

**WHEREAS**, pursuant to N.J.S.A. 40:20-1 the Board of County Commissioners for the County of Passaic (hereafter "Board") are vested with decision making powers on behalf of the County; and

**WHEREAS**, Preakness Healthcare Center (hereafter "Preakness") is a New Jersey Department of Health licensed, 406-bed skilled nursing facility that is owned and operated by the Passaic County Board of Chosen Freeholders (hereafter "Board"); and

**WHEREAS**, pursuant to N.J.S.A. 40A:11-4, et seq., for every contract awarded by the County for the provision or performance of any goods or services, the cost of which in the aggregate exceeds the bid threshold established pursuant to N.J.S.A. 40A:11-3, shall be awarded by resolution of the Board to the lowest responsible bidder after public advertising for bids and bidding thereof; and

**WHEREAS**, by virtue of Resolution No. R20200840 dated October 13, 2020, the Board appropriated six hundred ninety-five thousand dollars (\$695,000.00) to be spent on various products to be purchased from various vendors under SB-20-035, Medical and Dental Supplies Catalog Discount Pricing for the County of Passaic Departments and Institutions (hereafter "SB-20-035") for the period beginning September 1, 2020, through August 31, 2021; and

**WHEREAS**, by virtue of Resolution No. 20210354 dated April 13, 2021, the Board increased the award amount to the vendors under SB-20-035, to purchase additional products such as gloves, KN95 masks, and other personal protective equipment from said vendors in an amount not to exceed two hundred thousand dollars (\$200,000.00) to be awarded on an as-needed basis; and

**WHEREAS**, pursuant to N.J.S.A. 40A:11-15, a contract may be extended by mutual agreement of the parties to the contract when a contracting unit has commenced rebidding prior to the time the contract expires; and

**WHEREAS**, Preakness desires to extend the contracts with the various vendors under SB-20-035 for an additional four (4) months, commencing on September 1, 2021 through December 31, 2021 for a total increase in appropriation not to exceed two hundred thirty-one thousand six hundred seventy dollars (\$231,670.00); and

**WHEREAS**, Preakness desires to extend the contracts with vendors under SB-20-035, respectively, for a four (4) month term because, pursuant to N.J.S.A. 40A:11-15 Preakness has commenced the rebidding process prior to the expiration of said contracts; and

**WHEREAS**, funds are available in Account No. 1-01-27-172-001-M01 or any other account that may be deemed appropriate by the Chief Financial Officer or his designee, and the availability of funds has been contingently certified by the Chief Financial Officer subject to sufficient funds being appropriated by the Board in the 2021 and/or subsequent years' County budget(s), which is attached to and made part of this Resolution; and

**WHEREAS**, this matter was discussed at the July 28, 2021 Health and Human Services Committee, and is being recommended to the Board for approval; and

**NOW, THEREFORE LET IT BE RESOLVED**, pursuant to N.J.S.A. 40A:11-15, that the Board of County Commissioners of the County of Passaic hereby approves increasing the contract term of the various vendors under SB-20-035 by an additional four (4) months, and further approves increasing the appropriation thereunder in an not to exceed two hundred thirty-one thousand six hundred seventy dollars (\$231,670.00) for the purchase of medical and dental supplies on an as-needed basis during the extended contract term of September 1, 2021 through December 31, 2021 by Preakness Healthcare Center.

**LET IT BE FURTHER RESOLVED**, that the Clerk of the Board, County Counsel, and the Director of the Board are authorized to take any other steps necessary to carry out the purpose of this resolution.

KJB

August 10, 2021

COUNTY OF PASSAIC  
 PREAKNESS HEALTH, Co of Passaic  
 (O) 973-585-1493  
 305 OLDHAM RD - WYKENA GREEN  
 WAYNE, NJ 07470

REQUISITION	
NO.	R1-13541

S H I P T O	COUNTY OF PASSAIC PREAKNESS HEALTHCARE CENTER 305 OLDHAM ROAD WAYNE, NJ 07470
V E N D O R	VENDOR #: 11708 ALLSTATE MEDICAL SUPPLIES, LLC 34 35TH STREET BROOKLYN, NY 11232-2021

ORDER DATE: 07/02/21  
 DELIVERY DATE:  
 STATE CONTRACT:  
 F.O.B. TERMS:

QTY/UNIT	DESCRIPTION	ACCOUNT NO.	UNIT PRICE	TOTAL COST
1.00	Medical and Dental Supplies Effective September 2021  Resolution:_____ Date:_____	1-01-27-172-001-m01	50,000.0000	50,000.00
			TOTAL	50,000.00

Introduced on: August 10, 2021  
 Adopted on: August 10, 2021  
 Official Resolution#: R20210740

\_\_\_\_\_  
 REQUESTING DEPARTMENT DATE



COUNTY OF PASSAIC  
 PREAKNESS HEALTH, Co of Passaic  
 (Q) 973-585-1493  
 305 OLDHAM RD - WYKENA GREEN  
 WAYNE, NJ 07470

REQUISITION	
NO.	R1-13540

S H I P  T O	COUNTY OF PASSAIC PREAKNESS HEALTHCARE CENTER 305 OLDHAM ROAD WAYNE, NJ 07470
V E N D O R	VENDOR #: 07794 JML MEDICAL 1 HAVENWOOD COURT UNIT #502 LAKEWOOD, NJ 08701-4651

ORDER DATE: 07/02/21  
 DELIVERY DATE:  
 STATE CONTRACT:  
 F.O.B. TERMS:

QTY/UNIT	DESCRIPTION	ACCOUNT NO.	UNIT PRICE	TOTAL COST
1.00	Medical and Dental supplies Effective September 20201  Resolution: _____ Date: _____	1-01-27-172-001-M01	50,000.0000	50,000.00
			TOTAL	50,000.00

Introduced on: August 10, 2021  
 Adopted on: August 10, 2021  
 Official Resolution#: R20210740

\_\_\_\_\_  
 REQUESTING DEPARTMENT DATE

CERTIFICATION OF AVAILABLE FUNDS

THIS IS TO CERTIFY THAT FUNDS ARE AVAILABLE AS FOLLOWS:

AMOUNT: \$231,670.00

APPROPRIATION: 1-01-27-172-001-M01

PURPOSE: Authorizing increasing appropriation and a four month increase in contract term for medical and dental supplies Catalog Discount Pricing on an as-needed basis.



Richard Cahill, Director of Finance

DATED: August 10, 2021

# County of Passaic Board of County Commissioners

OFFICE OF COUNTY COMMISSIONERS

Director Pasquale "Pat" Lepore  
Deputy Director Bruce James  
Assad R. Akhter  
John W. Bartlett  
Theodore O. Best, Jr.  
Terry Duffy  
Cassandra "Sandi" Lazzara

401 Grand Street  
Paterson, New Jersey 07505  
Tel: 973-881-4402  
Fax: 973-742-3746

Anthony J. De Nova III  
*Administrator*  
Matthew P. Jordan, Esq.  
*County Counsel*  
Louis E. Imhof, III, RMC  
*Clerk Of The Board*



## Public Meeting (Board Meeting)

Date: Aug 10, 2021 - 5:30 PM

Location: County Administration Building  
Webex - 220  
401 Grand Street  
Paterson, NJ 07505

Agenda: RESOLUTION AUTHORIZING AN INCREASE IN THE APPROPRIATION TO C.A. SPINELLA, INC. FOR RESIDENTIAL WINDOW AND DOOR REPAIRS AND INSTALLATIONS AND DIVINE ENERGY SOLUTIONS, INC. FOR RESIDENTIAL INSULATION AND VENTILATION REPAIRS AND INTALLATION UNDER THE WEATHERIZATION PROGRAM, PURSUANT TO N.J.S.A 40A:11-15., ALL AS NOTED IN THE RESOLUTION.

THIS RESOLUTION WAS REQUESTED BY:  
WEATHERIZATION

REVIEWED BY:

Anthony J. De Nova III  
COUNTY ADMINISTRATOR

APPROVED AS TO FORM AND LEGALITY:

Matthew P. Jordan, Esq.  
COUNTY COUNSEL

Health & Human Services  
COMMITTEE NAME

<b>Official Resolution#</b>	<b>R20210741</b>							
Meeting Date	08/10/2021							
Introduced Date	08/10/2021							
Adopted Date	08/10/2021							
Agenda Item	I-25							
CAF #	G-01-41-705-020-213,							
Purchase Req. #								
Result	Adopted							
<b>COMMISSIONER</b>	<b>PRES.</b>	<b>ABS.</b>	<b>MOVE</b>	<b>SEC</b>	<b>AYE</b>	<b>NAY</b>	<b>ABST.</b>	<b>RECU.</b>
Lepore	✓				✓			
James	✓		✓		✓			
Akhter	✓			✓	✓			
Bartlett	✓				✓			
Best Jr.	✓				✓			
Duffy	✓				✓			
Lazzara	✓				✓			

PRES.= present ABS.= absent  
MOVE= moved SEC= seconded  
AYE= yes NAY= no ABST.= abstain  
RECU.= recuse

**RESOLUTION AUTHORIZING AN INCREASE IN THE APPROPRIATION TO C.A. SPINELLA, INC. FOR RESIDENTIAL WINDOW AND DOOR REPAIRS AND INSTALLATIONS AND DIVINE ENERGY SOLUTIONS, INC. FOR RESIDENTIAL INSULATION AND VENTILATION REPAIRS AND INTALLATION UNDER THE WEATHERIZATION PROGRAM, PURSUANT TO N.J.S.A. 40A:11-15.**

**WHEREAS**, the County of Passaic (hereafter “County”) is a government body incorporated pursuant to N.J.S.A. 40:18-1, et seq. and vested with all rights contained therein; and

**WHEREAS**, pursuant to N.J.S.A. 40:20-1 the Board of County Commissioners for the County of Passaic are vested with decision making powers on behalf of the County; and

**WHEREAS**, the County, through its Division of Weatherization and Home Energy (hereafter “Division”) of the Department of Senior Services administers various programs to reduce energy costs for low-income residents in Passaic County by improving energy efficiency; and

**WHEREAS**, pursuant to N.J.S.A. 40A:11-4, et seq., for every contract awarded by the County for the provision or performance of any goods or services, the cost of which in the aggregate exceeds the bid threshold established pursuant to N.J.S.A. 40A:11-3, shall be awarded by resolution of the Board to the lowest responsible bidder after public advertising for bids and bidding thereof; and

**WHEREAS**, the Purchasing Agent issued SB-18-031, Weatherization Program Residential Windows/Doors Repairs and Installation with Other Energy Conservation Measures (hereafter “SB-18-031”) and SB-18-032, Weatherization Program Residential Insulation and Ventilation Repairs and Installation with Other Energy Conservation Measures, (hereafter “SB-18-032”), each in compliance with N.J.S.A. 40A:11-4, et seq., that solicited competitive pricing from qualified vendors for the goods and services sought therein; and

**WHEREAS**, by virtue of Resolution No. R20180435 dated June 12, 2018, the County awarded a contract under SB-18-031 to C.A. Spinella, Inc for two (2) years with a one (1) year option to renew, and awarded a contract under SB-18-032 to Divine Energy Solutions, Inc. for two (2) years with a one (1) year option to renew; and

**WHEREAS**, by virtue of Resolution No. R20200401 dated May 19, 2020, the Board authorized the one-year extension under SB-18-031 for C.A. Spinella, Inc. and SB-18-032 for Divine Energy Solutions, Inc., respectively, each term commencing on June 1, 2020 and expiring May 31, 2021; and

**WHEREAS**, by virtue of Resolution No. R20210504 dated May 25, 2021, the Board authorized a three-month extension of the contracts with C.A. Spinella, Inc. under SB-18-031, and Divine Energy Solutions, Inc. under SB-18-032, each commencing on June 1, 2021 through August 31, 2021 for a total award amount not to exceed eighty thousand dollars (\$80,000.00)

**WHEREAS**, pursuant to N.J.S.A. 40A:11-15, a contract may be extended by mutual agreement of the parties to the contract when a contracting unit has commenced rebidding prior to the time the contract expires; and

**WHEREAS**, the Division desires to extend the contracts with C.A. Spinella, Inc. under SB-18-031, and Divine Energy Solutions, Inc. under SB-18-032, respectively for an additional three (3) months, commencing on September 1, 2021 through November 30, 2021 for a total award amount not to exceed one hundred seventy-five thousand dollars (\$175,000.00); and

**WHEREAS**, the Division desires to extend the contracts under SB-18-031 and SB-18-032, respectively, for a three (3) month term because the Division has commenced the rebidding process prior to the expiration of said contracts; and

**WHEREAS**, funds are available in Account No. G-01-41-705-020-213, G-01-41-708-020-213, and G-01-41-705-010-213, or any account that may be deemed appropriate by the Chief Financial Officer or his designee, and the availability of funds has been contingently certified by the Chief Financial Officer subject to sufficient funds being appropriated by the Board in the 2021 and/or subsequent years’ County budget(s), which is attached to and made part of this Resolution; and

**WHEREAS**, this matter was discussed at the July 28, 2021 meeting of the Health and Human Services Committee and is being recommended to the Board for approval; and

**NOW, THEREFORE, LET IT BE RESOLVED**, pursuant to N.J.S.A. 40A:11-15, the Board of County Commissioners of the County of Passaic hereby authorizes the extension of the contracts with C.A. Spinella, Inc. under SB-18-031, and Divine Energy Solutions, Inc. under SB-18-032 for an additional three (3) months, commencing on September 1, 2021 through November 30, 2021 for a total award amount not to exceed one hundred seventy-five thousand dollars (\$175,000.00).

**LET IT BE FURTHER RESOLVED**, that the Director of the Board of County Commissioners for the County of Passaic, the County Counsel, and Clerk of the Board are hereby authorized to take the necessary actions to execute any documents necessary to effectuate the purposes of this Resolution on behalf of the County of Passaic.

KJB

August 10, 2021

CERTIFICATION OF AVAILABLE FUNDS

THIS IS TO CERTIFY THAT FUNDS ARE AVAILABLE AS FOLLOWS:

AMOUNT: \$175,000.00

APPROPRIATION: G-01-41-705-020-213 - \$66,500.00  
G-01-41-708-020-213 - \$93,500.00  
G-01-41-705-010-213 - \$15,000.00

PURPOSE: Authorizing increase in appropriation and a three month increase in contract term for residential window and door repairs and installations and residential insulation and ventilation repairs and installation.

  
Richard Cahill, Director of Finance

DATED: August 10, 2021

# County of Passaic Board of County Commissioners

OFFICE OF COUNTY COMMISSIONERS

Director Pasquale "Pat" Lepore  
Deputy Director Bruce James  
Assad R. Akhter  
John W. Bartlett  
Theodore O. Best, Jr.  
Terry Duffy  
Cassandra "Sandi" Lazzara

401 Grand Street  
Paterson, New Jersey 07505  
Tel: 973-881-4402  
Fax: 973-742-3746

Anthony J. De Nova III  
*Administrator*  
Matthew P. Jordan, Esq.  
*County Counsel*  
Louis E. Imhof, III, RMC  
*Clerk Of The Board*



## Public Meeting (Board Meeting)

Date: Aug 10, 2021 - 5:30 PM

Location: County Administration Building  
Webex - 220  
401 Grand Street  
Paterson, NJ 07505

Agenda: RESOLUTION QUALIFYING A POOL OF LEAD REMEDIATORS AND LEAD ABATEMENT CONTRACTORS AND AWARDDING CONTRACTS TO PERFORM LEAD REMEDATION AND LEAD ABATEMENT SERVICES FOR THE DIVISION OF WEATHERIZATION, PURSUANT TO N.J.S.A 40A:11-5 ET SEQ., ALL AS NOTED IN THE RESOLUTION.

THIS RESOLUTION WAS REQUESTED BY:

WEATHERIZATION

REVIEWED BY:

Anthony J. De Nova III

COUNTY ADMINISTRATOR

APPROVED AS TO FORM AND LEGALITY:

Matthew P. Jordan, Esq.

COUNTY COUNSEL

Health & Human Services

COMMITTEE NAME

<b>Official Resolution#</b>	<b>R20210742</b>							
Meeting Date	08/10/2021							
Introduced Date	08/10/2021							
Adopted Date	08/10/2021							
Agenda Item	I-26							
CAF #								
Purchase Req. #								
Result	Adopted							
<b>COMMISSIONER</b>	<b>PRES.</b>	<b>ABS.</b>	<b>MOVE</b>	<b>SEC</b>	<b>AYE</b>	<b>NAY</b>	<b>ABST.</b>	<b>RECU.</b>
Lepore	✓				✓			
James	✓		✓		✓			
Akhter	✓			✓	✓			
Bartlett	✓				✓			
Best Jr.	✓				✓			
Duffy	✓				✓			
Lazzara	✓				✓			

PRES.= present ABS.= absent  
 MOVE= moved SEC= seconded  
 AYE= yes NAY= no ABST.= abstain  
 RECU.= recuse

**Dated: August 11, 2021**

**RESOLUTION QUALIFYING A POOL OF LEAD REMEDIATORS AND LEAD ABATEMENT CONTRACTORS AND AWARDING CONTRACTS TO PERFORM LEAD REMEDIATION AND LEAD ABATEMENT SERVICES FOR THE DIVISION OF WEATHERIZATION, PURSUANT TO N.J.S.A 40A:11-5 ET SEQ.**

**WHEREAS**, the County of Passaic (hereafter “County”) is a government body incorporated pursuant to N.J.S.A. 40:18-1, et seq. and vested with all rights contained therein; and

**WHEREAS**, pursuant to N.J.S.A. 40:20-1 the Board of County Commissioners for the County of Passaic are vested with decision making powers on behalf of the County; and

**WHEREAS**, the County, through its Division of Weatherization and Home Energy (hereafter “Division”) of the Department of Senior Services administers various programs to reduce energy costs for low-income residents in Passaic County by improving energy efficiency; and

**WHEREAS**, by virtue of Resolution No. R20210553 dated June 8, 2021, and Resolution No. R20210671 dated July 20, 2021, the Board accepted grant funds from the State of New Jersey, Department of Community Affairs, for the 2021 Lead-Safe Home Remediation Grant; and

**WHEREAS**, by virtue of Resolution No. R20210555 dated June 8, 2021, and Resolution No. R20210672 dated July 20, 2021, the Board accepted grant funds from the State of New Jersey, Department of Community Affairs, for the 2021 Single Family Home Remediation Grant; and

**WHEREAS**, the Division is conducting lead remediation and lead abatement work, requiring the retention of professional lead remediators and lead abatement contractors; and

**WHEREAS**, as a condition to accepting the above-described grants from the Department of Community Affairs, the Division is required to exclusively utilize lead remediation and lead abatement contractors that have been identified by a competitive request for qualifications procurement process conducted by Isles, Inc., a New Jersey nonprofit corporation working with the Department of Community Affairs and specializing in administering lead remediation and lead abatement programs; and

**WHEREAS**, pursuant to N.J.S.A. 40A:11-5, et seq., the Division desires to qualify the following contractors, identified by Isles, Inc. through its request for qualifications process: AAA Lead Professionals, Apex Development, Inc., BGI Resources International Corp., EnviroScience Solutions, LLC, Joseph Environmental, Optimum Environmental Solutions, LLC, Pow R Save, Inc., Tahshin Construction, LLC, The Wright Design, LLC, and Turningpoint Contracting Corp.; and

**WHEREAS**, pursuant to N.J.S.A. 40A:11-5, et seq., the Division desires to award contracts to the following contractors on an as needed basis with the contract term beginning April, 1, 2021 through March, 31, 2022 to AAA Lead Professionals, Apex Development, Inc., BGI Resources International Corp., EnviroScience Solutions, LLC, Joseph Environmental, Optimum Environmental Solutions, LLC, Pow R Save, Inc., Tahshin Construction, LLC, The Wright Design, LLC, and Turningpoint Contracting Corp. with a combined amount as to all contracts awarded herein not to exceed one hundred sixty thousand dollars (\$160,000.00); and

**WHEREAS**, funds are available in any account that may be deemed appropriate by the Chief Financial Officer or his designee, and the availability of funds has been contingently certified by the Chief Financial Officer subject to sufficient funds being appropriated by the Board in the 2021 and/or subsequent years’ County budget(s), which is attached to and made part of this Resolution; and

**WHEREAS**, this matter was discussed at the July 28, 2021 meeting of the Health and Human Services Committee and being recommended to the Board for approval; and

**NOW, THEREFORE, LET IT BE RESOLVED**, pursuant to N.J.S.A. 40A:11-5 et seq., the Board of County Commissioners of the County of Passaic, hereby authorizes an award of contract to the following contractors on an as needed basis with the contract term beginning April, 1, 2021 through March, 31, 2022 to AAA Lead Professionals, Apex Development, Inc., BGI Resources International Corp., EnviroScience Solutions, LLC, Joseph Environmental, Optimum Environmental Solutions, LLC, Pow R Save, Inc., Tahshin Construction, LLC, The Wright Design, LLC, and Turningpoint Contracting Corp. with a combined amount as to all contracts awarded herein not to exceed one hundred sixty thousand dollars (\$160,000.00)



**LET IT BE FURTHER RESOLVED**, the Clerk to the Board shall print, in the official newspaper, a brief notice stating the nature, duration, service, and amount of the contracts to AAA Lead Professionals, Apex Development, Inc., BGI Resources International Corp., EnviroScience Solutions, LLC, Joseph Environmental, Optimum Environmental Solutions, LLC, Pow R Save, Inc., Tahshin Construction, LLC, The Wright Design, LLC, and Turningpoint Contracting Corp. and maintain a copy of the resolution on file and available for public inspection in the Office of the Clerk to the Board.

**BE IT FURTHER RESOLVED** that the persons whose names and titles appear below are authorized to sign all necessary documents on behalf of the County of Passaic, and authorizes the Director of the Board of County Commissioners of the County of Passaic and Clerk of the Board of County Commissioners of the County of Passaic and any other County Official to execute the necessary agreements accordingly, and that they or their successors in said titles are authorized to sign the agreement and any other documents necessary in connection therewith:

Kevin Batacchi, Director  
Weatherization & Home Energy  
County of Passaic

Pasquale Lepore, Commissioner Director  
Board of County Commissioners  
County of Passaic

Louis E. Imhof III  
Clerk of the Board of  
County Commissioners  
County of Passaic

Matthew P. Jordan, Esq.  
County Counsel  
County of Passaic

KJB

August 10, 2021

**STATEWIDE OUTREACH AND COORDINATION OF LEAD GRANT SERVICES  
SUBGRANT AGREEMENT 2021**

This Subgrant Agreement (hereafter "Agreement") is entered into, effective as of March 1, 2021 (the "Effective Date") by and between the entities described below (hereafter "Party or "Parties" in the collective):

- (1) Isles, Inc., a New Jersey based non-profit corporation, which has its principal office at 10 Wood Street, Trenton, NJ 08618; and
- (2) The County of Passaic (hereafter "County"), a corporate body politic of the State of New Jersey, which has its principal office at 401 Grand Street, Paterson, NJ 07505.

**WHEREAS**

- A. Isles, Inc. is an organization that has been recognized by the IRS as tax-exempt under section 501(c)(3) of the Internal Revenue Code of 1986, with a mission to foster self-reliant families and healthy, sustainable communities.
- B. The County was founded in 1837, with decision making powers vested in the Passaic County Board of County Commissioners (hereafter "Board").
- C. The Passaic County Division of Weatherization and Home Energy administers energy assistance, weatherization assistance and lead assistance programs, to serve eligible residents throughout the County.
- D. Isles Inc. has received a grant from the New Jersey Department of Community Affairs (hereafter "NJDCA") to operate as the Statewide Outreach and Management of Lead Evaluation Services grantee, for NJDCA's Lead Assistance Program grants—including the Lead-Safe Home Remediation Grant Program and the Single-Family Home Remediation Program (hereafter "Lead Assistance Program"). In keeping with the intent and conditions of such grant, the County will designate a staff member to act as the Lead Hazard Control Supervisor for the County's Lead Assistance Program activities (hereafter "Lead Hazard Control Supervisor"). Isles agrees to reimburse the County for these staff costs for the coordination of lead evaluation and lead hazard control services for this statewide effort.
- E. This memorandum is intended solely for the purpose of recording expectations for budget estimates and work allocations for the County. It reflects an arrangement that currently is satisfactory to the parties; however, it is recognized and anticipated that changing circumstances of the evolving program will necessitate revisions. The parties agree to modify this memorandum to reflect such required adjustments as allowed within the NJDCA grant.
- F. Per the terms of the grant from NJDCA, Isles serves as the "fiscal agent" for the lead hazard control supervision and lead inspection/evaluation components of the grant. Isles has

determined that it is in its best interest to enter into a contract with the County to support the delivery of grant services in accordance with the terms of this Agreement.

NOW, THEREFORE, the parties hereby agree as follows:

## SECTION 1 SCOPE OF ENGAGEMENT.

### 1.1 Subgrant.

#### (A) Isles Inc.'s obligations:

- (i) Provide management, training, technical assistance and guidance to the designated Lead Hazard Control Supervisor with the County. The designated Lead Hazard Control Supervisor will perform all duties under the direction and guidance of Isles Inc.
- (ii) Reimburse the County for salary, fringe and related personnel costs to engage a Lead Hazard Control Supervisor, in a manner consistent with agency payroll billing schedule. The Lead Hazard Control Supervisor will carry out services under the Lead Assistance Program grants. Reimbursement is subject to the terms of this Agreement and NJDCA requirements for organizational expenses for work related to Lead Assistance Programs, and is subject to the availability of grant funding from for eligible County services, as determined by NJDCA.
- (iii) Under the guidance and within the rules of the NJDCA, and in compliance with N.J.S.A. 40A:11-1 et seq., create a "pool" of lead evaluation contractors for use by the County in the provision of 1) lead inspection risk assessments and 2) lead dust clearance examinations (hereafter "Lead Evaluators"). These Lead Evaluators meet all standards set by the State of New Jersey, and their use and payment for their services are detailed in Isles grant titled, "Statewide Outreach and Coordination of Lead Services". Per the "Statewide Outreach and Coordination of Lead Services" grant agreement and this Agreement, the County may not utilize lead evaluation services outside of this pool of Lead Evaluators unless they perform a separate RFQ process as required by NJDCA and pursuant to N.J.S.A. 40A:11-1 et seq.
- (iv) Under the guidance and within the rules of the New Jersey Department of Community Affairs (NJDCA) create a "pool" of qualified Lead Remediation and Abatement Contractors (hereafter "Lead Remediators") for use by the County in the provision of lead remediation or lead abatement services as required by the Lead Assistance Program grants. Lead Remediators meet all standards set by NJDCA in the Program Guidelines for the Lead Assistance Program. Lead Remediators are certified by the State of NJ and appear on the Certified Lead Abatement Contractors directory maintained by NJDCA.

Per this Agreement, the County may not utilize Lead Remediators outside of this pool, unless they perform a separate RFQ process as required by NJDCA and pursuant to N.J.S.A. 40A:11-1 et seq.

(B) County's obligations:

- (i) Assign a staff member who will perform as the Lead Hazard Control Supervisor to fulfill all grant requirements under the Lead Assistance Program. The Lead Hazard Control Supervisor shall perform all duties set forth in the Job Description (Attachment A) and the Lead Risk Assessment Flow Chart. Lead Hazard Control Supervisor shall (i) comply with Isles' programmatic directives; (ii) fulfill all programmatic responsibilities stipulated by Isles; and (iii) remain under Isles' guidance/supervision for the entirety of this Agreement. The Lead Hazard Control Supervisor can perform duties for other programs, provided that such other program duties would not interfere with his/her Lead Assistance Program capacity. The County cannot request reimbursement from Isles for the duties performed for other programs.
- (ii) The Lead Hazard Control Supervisor shall be available for all training and periodic technical assistance as needed by the program and as directed by Isles, Inc.
- (iii) Provide day to day supervision of the assigned staff member and will maintain all current employment conditions with regards to pay, benefits and other pertinent staff arrangements.
- (iv) Use only Lead Evaluators and Lead Remediators that are part of the qualified "pools" established by Isles under the guidance of NJDCA, provided that use of such Lead Evaluators and Lead Remediators is not violative of any provisions under N.J.S.A. 40A:11-1 et seq.
- (v) Keep records as required by NJDCA and submit timesheets and other payroll information to Isles Inc. in a timely manner.

1.2 Term or Termination Date: one (1) year, with a stipulation that unless termination is exercised pursuant to Section 5.2 herein, the contract automatically renews for an additional one (1) year.

1.3 Return of Unexpended Funds. N/A

## SECTION 2 CONDITIONS ON USE OF FUNDS.

2.1 Restricted Funds. The County may use the funds provided under this Agreement only to reimburse costs for the Lead Hazard Control Supervisor salary, fringe and related personnel costs.

**SECTION 3 RECORDKEEPING AND REPORTS.**

- 3.1 Financial Recordkeeping. The County shall maintain a separate fund on their books for all funds transferred from Isles Inc. under this Agreement, shall retain these records for at least five (5) years after NJDCA's receipt and acceptance of the final grant report, and shall provide such records to Isles Inc. or NJDCA, if requested.
- 3.2 Reports. The County shall submit reports as required by NJDCA and this Agreement.

**SECTION 4 INDEMNIFICATION**

- 4.1 **Release and Indemnity.** To the fullest extent permitted by law, each Party shall release, indemnify, defend and hold harmless the other Party and its directors, officers, trustees, employees, representatives and agents from and against any and all claims, demands, suits, damages, liabilities, injuries (personal or bodily), property damage, causes of action, losses, judgments, costs, expenses and penalties, including, without limitation, court costs and attorney's fees, arising out of (directly or indirectly) or related in any way to the negligent or wrongful acts or omissions of either Party or any Party's director, officer, employee or agent in connection with the Lead Assistance Program, except to the extent resulting from the negligent or wrongful acts or omissions of either Party.

**SECTION 5 GENERAL PROVISIONS.**

- 5.1 Entire Agreement, Amendment, and Waiver.
- (A) This Agreement contains the entire agreement of the Parties with respect to the subject matter of this Agreement.
  - (B) No provisions of this Agreement may be changed or modified except by written instrument signed by the Parties.
  - (C) Waiver by any Party of any term or condition of this Agreement or any breach hereof does not constitute a waiver of any other term or condition.
- 5.2 Termination and Survival.
- (A) This Agreement may be terminated by either Party, upon receipt of 30-days' notice in writing to the other Party and may be renegotiated at the option of the Parties.
  - (B) The County's obligations set forth in Sections 1.1, 1.3, 2, and 3 survive termination of this Agreement until all funds provided under this Agreement have been expended and accounted for.
  - (C) All Parties' obligation to maintain records documenting the uses of all funds provided under this Agreement shall survive for a period of five (5) years following the final expenditure of grant funds under this Agreement, unless NJDCA earlier provides assurances that no further records shall be requested

from the Parties to this Agreement.

5.3 Governing Law, Jurisdiction, and Venue.

- (A) This Agreement is governed in all respects, including validity, interpretation, and effect, by the internal law of the State of New Jersey, without regard to its conflicts-of-laws principles.
- (B) The jurisdictional venue for any legal matter involving this Agreement is in any appropriate state or federal court located in New Jersey.

5.4 Headings and Sections.

- (A) The subject headings used in this Agreement are included for purposes of reference and convenience only and may not affect the construction or interpretation of any of its provisions.
- (B) References in this Agreement to "Section" without elaboration are references to the numbered sections of this Agreement.

5.5 Counterpart and Facsimile Signatures.

- (A) This Agreement may be executed in multiple counterparts, each of which when so executed is deemed to be an original and all of which together, upon delivery, constitute one and the same agreement.
- (B) Facsimile signatures on this Agreement are as binding and enforceable as original signatures.
- (C) Each of the parties has caused this Agreement to be executed by its duly authorized signatory, as of the Effective Date.

Isles, Inc.

By: Peter W. Rose

Name: Peter W. Rose

Title: Managing Director

County of Passaic

By: Kevin J. Batacchi

Name: Kevin Batacchi

Title: Director, Weatherization and Home Energy Division

Date: 6/28/2021

CERTIFICATION OF AVAILABLE FUNDS

THIS IS TO CERTIFY THAT FUNDS ARE AVAILABLE AS FOLLOWS:

AMOUNT: \$160,000.00

APPROPRIATION: G-01-41-711-021-213 - \$80,000.00  
G-01-41-712-021-213 - \$80,000.00

PURPOSE: Awarding contracts to various contractors to perform lead remediation and lead abatement services.

  
Richard Cahill, Director of Finance

DATED: August 10, 2021



# County of Passaic Board of County Commissioners

OFFICE OF COUNTY COMMISSIONERS

Director Pasquale "Pat" Lepore  
Deputy Director Bruce James  
Assad R. Akhter  
John W. Bartlett  
Theodore O. Best, Jr.  
Terry Duffy  
Cassandra "Sandi" Lazzara

401 Grand Street  
Paterson, New Jersey 07505  
Tel: 973-881-4402  
Fax: 973-742-3746

Anthony J. De Nova III  
*Administrator*  
Matthew P. Jordan, Esq.  
*County Counsel*  
Louis E. Imhof, III, RMC  
*Clerk Of The Board*



## Public Meeting (Board Meeting)

Date: Aug 10, 2021 - 5:30 PM

Location: County Administration Building  
Webex - 220  
401 Grand Street  
Paterson, NJ 07505

Agenda: RESOLUTION RENAMING FRIENDSHIP PARK IN THE PASSAIC COUNTY PARK SYSTEM AS THE MAYOR DUNLEAVY MEMORIAL PARK, PURSUANT TO N.J.S.A. 40:20-1, ALL AS NOTED IN THE RESOLUTION.

THIS RESOLUTION WAS REQUESTED BY:

REVIEWED BY:

Anthony J. De Nova III  
COUNTY ADMINISTRATOR

APPROVED AS TO FORM AND LEGALITY:

Matthew P. Jordan, Esq.  
COUNTY COUNSEL

Public Works

COMMITTEE NAME

<b>Official Resolution#</b>	<b>R20210743</b>							
Meeting Date	08/10/2021							
Introduced Date	08/10/2021							
Adopted Date	08/10/2021							
Agenda Item	I-27							
CAF #								
Purchase Req. #								
Result	Adopted							
<b>COMMISSIONER</b>	<b>PRES.</b>	<b>ABS.</b>	<b>MOVE</b>	<b>SEC</b>	<b>AYE</b>	<b>NAY</b>	<b>ABST.</b>	<b>RECU.</b>
Lepore	✓				✓			
James	✓		✓		✓			
Akhter	✓			✓	✓			
Bartlett	✓				✓			
Best Jr.	✓				✓			
Duffy	✓				✓			
Lazzara	✓				✓			

PRES.= present ABS.= absent  
MOVE= moved SEC= seconded  
AYE= yes NAY= no ABST.= abstain  
RECU.= recuse

**Dated: August 11, 2021**

**RESOLUTION RENAMING FRIENDSHIP PARK IN THE PASSAIC COUNTY PARK SYSTEM  
AS THE MAYOR DUNLEAVY MEMORIAL PARK, PURSUANT TO N.J.S.A. 40:20-1**

**WHEREAS**, the County of Passaic (hereafter “County”) is a body politic and corporate pursuant to N.J.S.A. 40:18-1 and vested with all rights contained therein; and

**WHEREAS**, pursuant to N.J.S.A. 40:20-1 the Board of County Commissioners of the County of Passaic (hereafter “Board”) is vested with managing the property, finances, and affairs of the County; and

**WHEREAS**, pursuant to N.J.S.A. 40:32-7.7 the Board operates and maintains over sixteen thousand (16,000) acres of preserved open space and recreational facilities as part of the Passaic County Park System, through the Department of Parks and Recreation (hereafter “Department”); and

**WHEREAS**, Friendship Park is an approximately forty-four (44) acre recreational facility in the Passaic County Park System located at 50 Glenwild Avenue in the Borough of Bloomingdale, County of Passaic, State of New Jersey; and

**WHEREAS**, former Bloomingdale Mayor Jonathan Dunleavy served as Mayor since 2011, was a thirty-year resident of the Borough, and served as a Councilman, Cub Scout Leader, President of the Bloomingdale Youth Organization, helped establish the Bloomingdale Recreation and Open Space Trust Fund, and made lasting contributions to the betterment of recreational and open space facilities in Bloomingdale; and

**WHEREAS**, on November 6, 2020, at the age of 56, Mayor Dunleavy tragically passed away, after leaving a lasting impact of civic and personal contributions to the betterment of the Borough of Bloomindale; and

**WHEREAS**, in recognition of Mayor Dunleavy’s contributions to the Borough of Bloomindale and the County of Passaic, and specifically his advocacy for the preservation of open space and the improvement of recreational facilities during his life, the Board desires to rename Friendship Park as the Mayor Dunleavy Memorial Park; and

**WHEREAS**, this matter was discussed at the May 12, 2021 Public Works Committee, and is being recommended to the Board for approval.

**NOW, THEREFORE, LET IT BE RESOLVED**, pursuant to N.J.S.A. 40:20-1 that the Board of County Commissioners of the County of Passaic authorizes the renaming of Friendship Park in the Passaic County Park System as the Mayor Dunleavy Memorial Park.

**LET IT BE FURTHER RESOLVED**, that the Clerk of the Board, County Counsel, County Administrator, and Director of the Department of Parks and Recreation are authorized to take any action necessary to carry out the purpose of this Resolution.

MPJ

August 10, 2021

# County of Passaic Board of County Commissioners

OFFICE OF COUNTY COMMISSIONERS

Director Pasquale "Pat" Lepore  
Deputy Director Bruce James  
Assad R. Akhter  
John W. Bartlett  
Theodore O. Best, Jr.  
Terry Duffy  
Cassandra "Sandi" Lazzara

401 Grand Street  
Paterson, New Jersey 07505  
Tel: 973-881-4402  
Fax: 973-742-3746

Anthony J. De Nova III  
*Administrator*  
Matthew P. Jordan, Esq.  
*County Counsel*  
Louis E. Imhof, III, RMC  
*Clerk Of The Board*



## Public Meeting (Board Meeting)

Date: Aug 10, 2021 - 5:30 PM

Location: County Administration Building  
Webex - 220  
401 Grand Street  
Paterson, NJ 07505

Agenda: RESOLUTION AUTHORIZING AWARD OF CONTRACT TO THE VENDORS LISTED BELOW FOR PAPER GOODS, BAG LINERS, FOOD SERVICE SUPPLY AND RELATED PRODUCTS (BULK PURCHASE) FOR THE COUNTY OF PASSAIC DEPARTMENTS AND INSTITUTIONS AS PER BID SB-21-027 AND PURSUANT TO N.J.S.A. 40A 11-1 ET SEQ., ALL AS NOTED IN THE RESOLUTION.

THIS RESOLUTION WAS REQUESTED BY:

REVIEWED BY:

Anthony J. De Nova III  
COUNTY ADMINISTRATOR

APPROVED AS TO FORM AND LEGALITY:

Matthew P. Jordan, Esq.  
COUNTY COUNSEL

Public Works

COMMITTEE NAME

<b>Official Resolution#</b>	<b>R20210744</b>							
Meeting Date	08/10/2021							
Introduced Date	08/10/2021							
Adopted Date	08/10/2021							
Agenda Item	I-28							
CAF #								
Purchase Req. #								
Result	Adopted							
<b>COMMISSIONER</b>	<b>PRES.</b>	<b>ABS.</b>	<b>MOVE</b>	<b>SEC</b>	<b>AYE</b>	<b>NAY</b>	<b>ABST.</b>	<b>RECU.</b>
Lepore	✓				✓			
James	✓		✓		✓			
Akhter	✓			✓	✓			
Bartlett	✓				✓			
Best Jr.	✓				✓			
Duffy	✓				✓			
Lazzara	✓				✓			

PRES.= present ABS.= absent  
MOVE= moved SEC= seconded  
AYE= yes NAY= no ABST.= abstain  
RECU.= recuse

Dated: August 11, 2021

**RESOLUTION AUTHORIZING AWARD OF CONTRACT TO THE VENDORS LISTED BELOW FOR PAPER GOODS, BAG LINERS, FOOD SERVICE SUPPLY AND RELATED PRODUCTS (BULK PURCHASE) FOR THE COUNTY OF PASSAIC DEPARTMENTS AND INSTITUTIONS AS PER BID SB-21-027 AND PURSUANT TO N.J.S.A. 40A 11-1 ET SEQ.**

**WHEREAS**, the County of Passaic (hereafter "County") is a government body incorporated pursuant to N.J.S.A. 40:18-1, et seq. and vested with all rights contained therein; and

**WHEREAS**, pursuant to N.J.S.A. 40:20-1, the Board of County Commissioners for the County of Passaic (hereafter "Board") is vested with decision making powers on behalf of the County; and

**WHEREAS**, pursuant to N.J.S.A. 40A:11-4, et seq., every contract awarded by the County, for the provision or performance of any goods or services, the cost of which in the aggregate exceeds the bid threshold [40A:11-3], shall be awarded only by resolution of the Board to the lowest responsible bidder after public advertising for bids and bidding thereof; and

**WHEREAS**, in accordance with N.J.S.A. 40A:11-11, et seq., the County of Passaic is the lead public agency for #38PCCP New Jersey Cooperative; and

**WHEREAS**, the County issued a public solicitation to qualified vendors for SB-21-027 Paper Goods, Bag Liners, Good Service Supply and related Products (Bulk Purchase) for the County of Passaic Departments and Institutions in accordance with "Fair and Open" procedures as established in N.J.S.A. 19:44A-20.4 et seq.; and

**WHEREAS**, on June 4, 2021, the Purchasing Agent issued SB-21-027 Paper Goods, Bag Liners, Foodservice Supply and Related Products, as needed Bulk Purchase for the County of Passaic Departments and Institution, Bid No. SB-21-027 (hereafter "SB-21-027") seeking sealed proposals from qualified bidders for bulk purchase for various Passaic County Departments, to be used on an as-needed basis; and

**WHEREAS**, on June 16, 2021, bids were unsealed for SB-21-027 by the Purchasing Agent with six (6) responses from qualified bidders below were received; and

**WHEREAS**, the Superintendent of Buildings and Grounds is recommending an award of contract to the vendors listed below for a contract term beginning September 1, 2021 and expiring August 31, 2023 and an appropriation of six hundred thousand dollars (\$600,000.00) to purchase goods and services on an as-need basis; and

<b>Vendor</b>	<b>Category</b>	<b>Bid Total</b>
Unipak Corp 2766 East 63 St. Brooklyn, NY 11234	Supplies Bulk Purchases	2 Items \$142,650
Central Policy -Bag Corp 2400 Bedle Place Linden NJ 07036	Supplies Bulk Purchases	13 Items \$376,410
Interboro Packaging Corp. 114 Bracken Rd. Montgomery, NY 12549	Supplies Bulk Purchases	12 Items \$253,364.30
Spruce Industries 759 East Lincoln Ave Rahway NJ 07065	Supplies Bulk Purchases	6 Items \$224,440
APPCO Paper & Plastic Corp. 3949 Austin Boulevard Island Park, NY 11558	Supplies Bulk Purchases	32 Items Subject to tally
Imperial Bag & Paper Co LLC 255 Route 4 and 9 Jersey City, NJ 07306	Supplies Bulk Purchases	70 Items \$1,147,083.95

**WHEREAS**, the County complied with the legal requirements as set forth under N.J.S.A. 40A:11-23 and the County is making the award of contract within sixty (60) days of the bid opening, as required under N.J.S.A. 40A:11-24(a); and

**WHEREAS**, funds are available in an account that may be deemed appropriate by the Chief Financial Officer or his designee, and the availability of funds has been contingently certified by the Chief Financial Officer subject to sufficient funds being appropriated by the Board in the 2021 and/or subsequent years' County budget (s), which is attached to and made part of this Resolution.

**WHEREAS**, this matter was discussed at the July 28, 2021, Public Works Committee, and is being recommended to the Board for approval.

**NOW, THEREFORE, LET IT BE RESOLVED**, pursuant to N.J.S.A. 40A:11-1, et seq. the Board of County Commissioners of the County of Passaic authorizes an award of contract to vendors listed above for Paper Goods, Bag Liners, Foodservice Supply Related Products (Bulk Purchase) for the County of Passaic Departments and Institution for a term beginning September 1, 2021 and expiring August 31, 2023.

**LET IT BE FURTHER RESOLVED**, that the Chief Financial Officer is authorized to appropriate six hundred thousand dollars (\$600,000.00) to be used by the various departments listed above for clean uniform janitorial supplies to be used on an as-needed basis.

**LET IT BE FURTHER RESOLVED**, that the Clerk of the Board, County Counsel, Director of the Board of County Commissioners, and Purchasing Agent are authorized to execute an agreement with the vendors and take any other steps necessary to carry out the purpose of this Resolution.

NDA

August 10, 2021

Sherry Arvanitidis, Q.P.A.  
Purchasing Agent

**COUNTY OF PASSAIC**  
**BID TALLY SHEET**  
**Straight Bids**

Matthew Jordan, Esq.  
County Counsel  
Nadège Allwaters, Esq.  
Deputy County Counsel

**PURCHASING DEPARTMENT**

Taken by: Kevin McDuffie  
Typed by: Lisa Stacevitz  
Tiffany Brown  
Bids received at 10:30 a.m. on June 16, 2021 at the Passaic County Procurement Center 495 River Street Second Floor Paterson, NJ 07524  
SB-21-027 Paper Goods, Bag Liners, Foodservice Supply and Related Products, As Needed (Bulk Purchase)

Vendor	Act of Abolish	Disc. Stm.	New Coll. Adt.	Disc. I/A Item	Business Bag. Cert.	Avail to Co-Op	Bid Total
UNIPAK CORP 2766 EAST 69th STREET BROOKLYN NEW YORK 11234-6814	X	X	X	X	X	YES	2 ITEMS \$142,650
CENTRAL POLY-BAG CORP. 2400 BEDLE PLACE LINDEN NEW JERSEY 07036	X	X	X	X	X	YES	13 ITEMS \$376,410
INTERBORO PACKAGING CORP 114 BRACKEN RD MONTGOMERY, NY 12549	X	X	X	X	X	YES	12 ITEMS \$253,364.30

Sherry Arvanitakis, Q.P.A.  
Purchasing Agent

**COUNTY OF PASSAIC**  
**BID TALLY SHEET**  
**Straight Bids**

Matthew Jordan, Esq.  
County Counsel  
Nadege Allwaters, Esq.  
Deputy County Counsel

Taken by: Kevin McDuffie  
Taken by: Lisa Stacevich  
Typed by: Tiffany Brown

**PURCHASING DEPARTMENT**

Bids received at 10:30 a.m. on June 16, 2021 at the Passaic County Procurement Center, 495 River Street Second Floor, Paterson, NJ 07524  
**SB-21-027 Paper Goods, Bag Liners, Foodservice Supply and Related Products, As Needed (Bulk Purchase)**

Vendor	Adt. of Address	Disc. Stim.	Non-Coll. AE	Disc. IA Loan	Business Reg. Cert.	Avail to Go-Op	Bid Total
SPRUCE INDUSTRIES 759 E. LINCOLN AVE RAHWAY NEW JERSEY 07065	X	X	X	X	X	YES	6 ITEMS \$224,440
ALL AMERICAN POLY 40 TURNER PLACE PISCATAWAY, NJ 08854 <i>NOT RUNNING BID</i>	X	X	X	X	X	NO	5 ITEMS \$245,860.50
APPCO PAPER & PLASTICS CORP. 3949 AUSTIN BOULEVARD ISLAND PARK, NY 11558	X	X	X	X	X	YES	32 ITEMS SUBJECT TO TALLY

Sherry Arvanitakis, Q.P.A.  
Purchasing Agent

**COUNTY OF PASSAIC**  
**BID TALLY SHEET**  
**Straight Bids**

Matthew Jordan, Esq.  
County Counsel  
Nadege Allwaters, Esq.  
Deputy County Counsel

**PURCHASING DEPARTMENT**

**Bids received at 10:30 a.m. on June 16, 2021 at the Passaic County Procurement Center, 495 River Street Second Floor, Paterson, NJ 07524**  
**SB-21-027 Paper Goods, Bag Liners, Foodservice Supply and Related Products, As Needed (Bulk Purchase)**

Taken by: Kevin McDuffie  
Typed by: Lisa Stacevich  
Tiffany Brown

Vendor	Ask of Awards	Disc. Str.	Non-Gen. A/E	Disc. I/A Item	Business Reg. Cert.	Avail to Co-Ops	Bid Total
IMPERIAL BAG & PAPER CO, LLC 255 ROUTE 1 AND 9 JERSEY CITY, NJ 07306	X	X	X	X	X	NO	70 ITEMS \$1,147,083.95



CERTIFICATION OF AVAILABLE FUNDS

THIS IS TO CERTIFY THAT FUNDS ARE AVAILABLE AS FOLLOWS:

AMOUNT: \$600,000.00

APPROPRIATION: Various accounts on as-needed basis.

PURPOSE: Authorizing award of contracts to various vendors for paper goods, bag liners, food service supply and related products in bulk..

  
\_\_\_\_\_  
Richard Cahill, Director of Finance

DATED: August 10, 2021

# County of Passaic Board of County Commissioners

OFFICE OF COUNTY COMMISSIONERS

Director Pasquale "Pat" Lepore  
Deputy Director Bruce James  
Assad R. Akhter  
John W. Bartlett  
Theodore O. Best, Jr.  
Terry Duffy  
Cassandra "Sandi" Lazzara

401 Grand Street  
Paterson, New Jersey 07505  
Tel: 973-881-4402  
Fax: 973-742-3746

Anthony J. De Nova III  
*Administrator*  
Matthew P. Jordan, Esq.  
*County Counsel*  
Louis E. Imhof, III, RMC  
*Clerk Of The Board*



## Public Meeting (Board Meeting)

Date: Aug 10, 2021 - 5:30 PM

Location: County Administration Building  
Webex - 220  
401 Grand Street  
Paterson, NJ 07505

Agenda: RESOLUTION AUTHORIZING AWARD OF CONTRACT TO THE VENDORS LISTED BELOW FOR JANITORIAL SUPPLIES CATALOG % DISCOUNTS PRICING FOR THE COUNTY OF PASSAIC DEPARTMENTS AND INSTITUTIONS WITH A ONE YEAR OPTION TO RENEW AS PER BID SB-21-053 AND PURSUANT TO N.J.S.A. 40A 11-1 ET SEQ., ALL AS NOTED IN THE RESOLUTION.

THIS RESOLUTION WAS REQUESTED BY:

REVIEWED BY:

Anthony J. De Nova III  
COUNTY ADMINISTRATOR

APPROVED AS TO FORM AND LEGALITY:

Matthew P. Jordan, Esq.  
COUNTY COUNSEL

Public Works

COMMITTEE NAME

<b>Official Resolution#</b>	<b>R20210745</b>							
Meeting Date	08/10/2021							
Introduced Date	08/10/2021							
Adopted Date	08/10/2021							
Agenda Item	I-29							
CAF #								
Purchase Req. #								
Result	Adopted							
<b>COMMISSIONER</b>	<b>PRES.</b>	<b>ABS.</b>	<b>MOVE</b>	<b>SEC</b>	<b>AYE</b>	<b>NAY</b>	<b>ABST.</b>	<b>RECU.</b>
Lepore	✓				✓			
James	✓		✓		✓			
Akhter	✓			✓	✓			
Bartlett	✓				✓			
Best Jr.	✓				✓			
Duffy	✓				✓			
Lazzara	✓				✓			

PRES.= present ABS.= absent  
MOVE= moved SEC= seconded  
AYE= yes NAY= no ABST.= abstain  
RECU.= recuse

Dated: August 11, 2021

**RESOLUTION AUTHORIZING AWARD OF CONTRACT TO THE VENDORS LISTED BELOW FOR JANITORIAL SUPPLIES CATALOG % DISCOUNTS PRICING FOR THE COUNTY OF PASSAIC DEPARTMENTS AND INSTITUTIONS WITH A ONE YEAR OPTION TO RENEW AS PER BID SB-21-053 AND PURSUANT TO N.J.S.A. 40A 11-1 ET SEQ.**

**WHEREAS**, the County of Passaic (hereafter “County”) is a government body incorporated pursuant to N.J.S.A. 40:18-1, et seq. and vested with all rights contained therein; and

**WHEREAS**, pursuant to N.J.S.A. 40:20-1, the Board of County Commissioners for the County of Passaic (hereafter “Board”) is vested with decision making powers on behalf of the County; and

**WHEREAS**, pursuant to N.J.S.A. 40A:11-4, et seq., every contract awarded by the County, for the provision or performance of any goods or services, the cost of which in the aggregate exceeds the bid threshold [40A:11-3], shall be awarded only by resolution of the Board to the lowest responsible bidder after public advertising for bids and bidding thereof; and

**WHEREAS**, in accordance with N.J.S.A. 40A:11-11, et seq., the County of Passaic is the lead public agency for the #38PCCP New Jersey Cooperative; and

**WHEREAS**, the County of Passaic issued a public solicitation to qualified vendors for SB-21-053 Janitorial Supplies Catalog Discount Pricing for the County of Passaic Departments and Institutions in accordance with “Fair and Open procedures as established in N.J.S.A. 19:44A-20.4 et seq.; and

**WHEREAS**, on June 22, 2021, the Purchasing Agent issued SB-21-053 Janitorial Supplies Catalog % Discount Pricing for the County of Passaic Departments and Institution, Bid No. SB-21-053 (hereafter “SB-21-053”) seeking sealed proposals from qualified bidders for janitorial supplies for various Passaic County Departments, to be used on an as-needed basis; and

**WHEREAS**, on July 8, 2021, bids were unsealed for SB-21-053 by the Purchasing Agent with seven (7) responses from qualified bidders listed below were received; and

**WHEREAS**, the Superintendent of Buildings and Grounds is recommending an award of contract to the vendors listed below for a contract term beginning September 1, 2021 and expiring August 31, 2022 with a one year option to renew, and an appropriation of three hundred and fifty thousand dollars (\$350,000.00) to purchase goods and services on an as-need basis; and

<b>Vendor</b>	<b>Category</b>	<b>Manufacturer price sheet &amp; date</b>	<b>% Discount</b>
Imperial Bag & Paper Co. 225 Rt. 1 & 9 South Jersey City, NJ 07306	Janitorial	1.Imperial DADE 2.SC Johnson’s 3.Spartan Chemical	1. 33% 2. 18% 3. 23%
Pariser Industries Inc. 91 Michigan Ave. Paterson, NJ 07503	Janitorial	1. WWS- Ware-With all Food service 2. RCS-Room Care Systems Janitorial Chemicals 3. Exception-San-Man hand sanitizer	1. 25% 2. 25% 3. 40%
Spruce Industries 759 East Lincoln Ave Rahway NJ 07065	Janitorial	1.Triples 2.Spartan	1. 20% 2. 20%
Unipak Corp 2766 East 63 St. Brooklyn, NY 11234	Janitorial	1.Personal Protective Equipment a. Plastic bags b. PPE c. Gloves	1a. 20% 1b. 20% 1c. 10%
TSP Maintenance Supply 52 E. Drive Livingston NJ 07039	Janitorial	TSP Maintenance Supplies	60%
United Sales US Corp. 185 30 <sup>th</sup> Street	Janitorial	Facility cleaning and maintenance solution	51%

Brooklyn NY 11232			
Zep, Inc. 3330 Cumberland Blvd. Ste 700 Atlanta GA 30339	Janitorial	1. ZEP Catalog a. chemicals b. equipment & other supplies	1a. 38% 1b.25%

**WHEREAS**, the County complied with the legal requirements as set forth under N.J.S.A. 40A:11-23 and the County is making the award of contract within sixty (60) days of the bid opening, as required under N.J.S.A. 40A:11-24(a); and

**WHEREAS**, funds are available in an account that may be deemed appropriate by the Chief Financial Officer or his designee, and the availability of funds has been contingently certified by the Chief Financial Officer subject to sufficient funds being appropriated by the Board in the 2021 and/or subsequent years' County budget (s), which is attached to and made part of this Resolution.

**WHEREAS**, this matter was discussed at the July 28, 2021, Public Works Committee, and is being recommended to the Board for approval.

**NOW, THEREFORE, LET IT BE RESOLVED**, pursuant to N.J.S.A. 40A:11-1, et seq. the Board of County Commissioners of the County of Passaic authorizes an award of contract to vendors listed above for Janitorial supplies catalog % discount pricing for the County of Passaic Departments and Institution for a term beginning September 1, 2021, and expiring August 31, 2022 with a one year option to renew.

**LET IT BE FURTHER RESOLVED**, that the Chief Financial Officer is authorized to appropriate three hundred and fifty thousand dollars (\$350,000.00) to be used by the various departments listed above for clean uniform janitorial supplies to be used on an as-needed basis.

**LET IT BE FURTHER RESOLVED**, that the Clerk of the Board, County Counsel, Director of the Board of County Commissioners, and Purchasing Agent are authorized to execute an agreement with Clean Rental Uniforms and take any other steps necessary to carry out the purpose of this Resolution.

NDA

August 10, 2021

9/1/21 - 8/31/22

**COUNTY OF PASSAIC  
 BID TALLY SHEET  
 Straight Bids**

Sherry Arvanitakis, Q.P.A.  
 Purchasing Agent

Matthew Jordan, Esq.  
 County Counsel  
 Nadege Allwaters, Esq.  
 Deputy County Counsel

Taken by: Kevin McDuffie  
 Taken by: Lisa Stacevitz  
 Typed by: Monika Ferrac

**PURCHASING DEPARTMENT**

Bids received at JULY 8, 2021 10:30 a.m. on at the Passaic County Procurement Center, 495 River Street Second Floor, Paterson, NJ 07524  
**SB-21-053 JANITORIAL SUPPLIES CATALOG % DISCOUNT PRICING FOR THE COUNTY OF PASSAIC DEPARTMENTS AND INSTITUTIONS**

Vendor	Act of Addenda	Disc. Stim.	Non-Call All	Disc. I/A Item	Business Reg. Cert.	Avail to Co-Op	Bid Total
Imperial Bag and Paper Co 255 Rt.1 & 9 South Jersey City NJ 07306	X	X	X	X	X	YES	Imperial DADE -33% SC Johnson's -18% Spartan Chemical -23%
Prizer Industries Inc 91 Michigan Ave. Paterson NJ 07503	X	X	X	X	X	YES	"WWS" Ware -With -all Food service, ware washing chemicals -25% "RCS" Room care systems Janitorial chemicals -25% Exception: San - Man hand sanitizer -40%
Spruce Industries 759 East Lincoln Ave Rahway NJ 07065	X	X	X	X	X	YES	Triples - 20% off Spartan - 20% off

**COUNTY OF PASSAIC  
 BID TALLY SHEET  
 Straight Bids**

Sherry Arvanitakis, Q.P.A.  
 Purchasing Agent

Matthew Jordan, Esq.  
 County Counsel  
 Nadege Aliwaters, Esq.  
 Deputy County Counsel

Taken by: Kevin McDuffie  
 Taken by: Lisa Stacevich  
 Typed by: Monika Perenc

**PURCHASING DEPARTMENT**

Bids received at JULY 8, 2021 10:30 a.m. on at the Passaic County Procurement Center, 495 River Street Second Floor, Paterson, NJ 07524  
**SB-21-053 JANITORIAL SUPPLIES CATALOG % DISCOUNT PRICING FOR THE COUNTY OF PASSAIC DEPARTMENTS AND INSTITUTIONS**

Vendor	Ack of Addenda	Disc. Stan.	Non-Coll Aff	Disc. I/A Item	Business Reg. Cert.	Avail to Co-Op	Bid Total
Unibak Corp. 2766 East 63 St Brooklyn NY 11234	X	X	X	X	X	YES	Personal Protective Equipment (PPE) 20% - Plastics Bags 20% - PPE 10% - Gloves
TSP Maintenance Supply 52 East Drive Livingston NJ 07039	X	X	X	X	X	YES	TSP Maintenance Supply - 60% off
United Sales US Corp. 145 30 TH Street Brooklyn NY 11231	X	X	X	X	X	YES	Facility cleaning and Maintenance solution - 51%

**COUNTY OF PASSAIC  
 BID TALLY SHEET  
 Straight Bids**

Sherry Arvanitakis, Q.P.A.  
 Purchasing Agent

Matthew Jordan, Esq.  
 County Counsel  
 Nadege Aliwaters, Esq.  
 Deputy County Counsel

Taken by:  
 Taken by:  
 Typed by:

**PURCHASING DEPARTMENT**

Bids received at JULY 8, 2021 10:30 a.m. on at the Passaic County Procurement Center, 495 River Street Second Floor, Paterson, NJ 07524  
**SB-21-053 JANITORIAL SUPPLIES CATALOG % DISCOUNT PRICING FOR THE COUNTY OF PASSAIC DEPARTMENTS AND INSTITUTIONS**

Vendor	Ack of Addenda	Disc. Str.	Non-Call Aff.	Dist. VA Iran	Business Reg. Cert.	Avail to Co-Op	Bid Total
Zep, Inc 3336 Chamberland Blvd, Suite 700 Atlanta Ga, 30329	X	X	X	X	Not Submitted	Yes	Zep Catalog -- 38% off chemicals -25% off equipment and other supplies

Introduced on: August 10, 2021  
 Adopted on: August 10, 2021  
 Official Resolution#: R20210745

CERTIFICATION OF AVAILABLE FUNDS

THIS IS TO CERTIFY THAT FUNDS ARE AVAILABLE AS FOLLOWS:

AMOUNT: \$350,000.00

APPROPRIATION: All accounts on a needs basis

PURPOSE: Authorizing award of contract to the vendors listed on the attached resolution for janitorial supplies for various County of Passaic Departments and Institutions for the period of September 1, 2021 through August 31, 2022.



Richard Cahill, Director of Finance

DATED: August 10, 2021



# County of Passaic Board of County Commissioners

OFFICE OF COUNTY COMMISSIONERS

Director Pasquale "Pat" Lepore  
Deputy Director Bruce James  
Assad R. Akhter  
John W. Bartlett  
Theodore O. Best, Jr.  
Terry Duffy  
Cassandra "Sandi" Lazzara

401 Grand Street  
Paterson, New Jersey 07505  
Tel: 973-881-4402  
Fax: 973-742-3746

Anthony J. De Nova III  
*Administrator*  
Matthew P. Jordan, Esq.  
*County Counsel*  
Louis E. Imhof, III, RMC  
*Clerk Of The Board*



## Public Meeting (Board Meeting)

Date: Aug 10, 2021 - 5:30 PM

Location: County Administration Building  
Webex - 220  
401 Grand Street  
Paterson, NJ 07505

Agenda: RESOLUTION AUTHORIZING THE PURCHASE OF TWO 2022 FORD F-550 VEHICLES FROM ROUTE 23 AUTOMALL, LLC FOR USE BY THE DIVISION OF ROADS, PURSUANT TO N.J.S.A. 40A:11-12, ET SEQ., ALL AS NOTED IN THE RESOLUTION.

THIS RESOLUTION WAS REQUESTED BY:

REVIEWED BY:

Anthony J. De Nova III  
COUNTY ADMINISTRATOR

APPROVED AS TO FORM AND LEGALITY:

Matthew P. Jordan, Esq.  
COUNTY COUNSEL

Public Works

COMMITTEE NAME

<b>Official Resolution#</b>	<b>R20210746</b>							
Meeting Date	08/10/2021							
Introduced Date	08/10/2021							
Adopted Date	08/10/2021							
Agenda Item	I-30							
CAF #	1-01-44-900-003-000							
Purchase Req. #								
Result	Adopted							
<b>COMMISSIONER</b>	<b>PRES.</b>	<b>ABS.</b>	<b>MOVE</b>	<b>SEC</b>	<b>AYE</b>	<b>NAY</b>	<b>ABST.</b>	<b>RECU.</b>
Lepore	✓				✓			
James	✓		✓		✓			
Akhter	✓			✓	✓			
Bartlett	✓				✓			
Best Jr.	✓				✓			
Duffy	✓				✓			
Lazzara	✓				✓			

PRES.= present ABS.= absent  
MOVE= moved SEC= seconded  
AYE= yes NAY= no ABST.= abstain  
RECU.= recuse

Dated: August 11, 2021

**RESOLUTION AUTHORIZING THE PURCHASE OF TWO 2022 FORD F-550 VEHICLES FROM ROUTE 23 AUTOMALL, LLC FOR USE BY THE DIVISION OF ROADS, PURSUANT TO N.J.S.A. 40A:11-12, ET SEQ.**

**WHEREAS**, the County of Passaic (hereafter "County") is a government body incorporated pursuant to N.J.S.A. 40:18-1, et seq. and vested with all rights contained therein; and

**WHEREAS**, pursuant to N.J.S.A. 40:20-1 the Passaic Board of County Commissioners (hereafter "Board") is vested with decision making powers on behalf of the County; and

**WHEREAS**, pursuant to N.J.S.A. 40A:11-12, et seq., the County may, without advertising for bids, purchase goods or services under any contract or contracts for such goods or service entered into on behalf of the State by the Division of Purchase and Property in the Department of Treasury; and

**WHEREAS**, Route 23 Automall, LLC submitted competitive pricing for two (2) 2022 Ford F-550 Chassis 4x4 SD Crew Cab 203" WB DRW XL (W5H), Master Purchase Blanket Order No. 17-FLEET-00241, to the State of New Jersey, Division of Purchase of Property in the Department of Treasury; and

**WHEREAS**, the Supervisor of Roads is seeking authorization for the purchase of two (2) 2022 Ford F-550 Chassis 4x4 SD Crew Cab 203" WB DRW XL (W5H) in an amount not to exceed one hundred eighty-five thousand seven hundred sixteen dollars (\$185,716.00); and

**WHEREAS**, on April 27, 2021, Board passed Resolution R20210428 authorizing the purchase of 2022 Ford F-450 WD Reg Cab 145" WB 60" CA XL Base Model from Beyer Ford, LLC in an amount not to exceed one hundred sixty-eight thousand five hundred fifty-seven dollars (\$168,557.00); and

**WHEREAS**, the Supervisor of Roads is requesting that the Board rescind Resolution R20210428 authorizing the purchase of vehicles from Beyer Ford, LLC because the Beyer is not able to provide the vehicles for the quoted price; and

**WHEREAS**, funds are available in Account No.1-01-44-900-003-000 or any other account that may be deemed appropriate by the Chief Financial Officer or his designee, and the availability of funds has been contingently certified by the Chief Financial Officer subject to sufficient funds being appropriated by the Board in the 2021 and/or subsequent years' County budget (s), which is attached to and made part of this Resolution; and

**WHEREAS**, this matter was discussed at the meeting on July 28, 2021 by the Public Works Committee and is being recommended to the Board for approval.

**NOW, THEREFORE, LET IT BE RESOLVED**, pursuant to N.J.S.A. 40A:11-12, et seq., that the Board of County Commissioners of the County of Passaic hereby authorizes the purchase of (2) 2022 Ford F-550 Chassis 4x4 SD Crew Cab 203 WB DRW XL (W5H) in an amount not to exceed one hundred eighty-five thousand seven hundred sixteen dollars (\$185,716.00) from Route 23 Automall.

**LET IT BE FURTHER RESOLVED**, that the Board Rescinds Resolution R20210428 authorizing the purchase of two (2) 2022 Ford F-450 WD Reg Cab 145" WB 60" CA XL Base Model from Beyer Ford, LLC.

**LET IT BE FURTHER RESOLVED**, that the Purchasing Agent and all other necessary officers and employees be and hereby are authorized and directed to take such further actions and sign such documents as are necessary to effectuate the purpose of this Resolution, including but not limited to issuance of an appropriate Purchase Order.

NDA

August 10, 2021

COUNTY OF PASSAIC

ROADS DEPT, CO OF PASSAIC  
 (Q) 973-881-4500  
 1310 ROUTE 23 NORTH  
 WAYNE, NJ 07470

REQUISITION	
NO.	R1-13727

SHIP TO	COUNTY OF PASSAIC ROAD DEPARTMENT 1310 ROUTE 23 NORTH WAYNE, NJ 07470
VENDOR	VENDOR #: 04422 ROUTE 23 AUTOMALL 1301 ROUTE 23 SOUTH BUTLER, NJ 07405

ORDER DATE: 07/20/21  
 DELIVERY DATE:  
 STATE CONTRACT: 17-FLEET-00241  
 F.O.B. TERMS:

QTY/UNIT	DESCRIPTION	ACCOUNT NO.	UNIT PRICE	TOTAL COST
2.00	ROAD DEPARTMENT - WAYNE TWO (2) 2022 FORD F-550 CHASSIS 4X4 SD CREW CAB 203" WB DRW XL (WSH) AS PER SPECIFICATIONS CONTAINED IN QUOTE #PASSW5HNJ, DATED JUNE 1, 2021 AND PROVIDE AND INSTALL A GALION MODEL 133USD-9' STAINLESS STEEL DUMP BODY ON TO 2022 FORD F-550, CREW CAB, GAS ENGINE, AUTO TRANS, 60" CA, DUAL REAR WHEEL AS CONTAINED IN QUOTE #21-0056, 5/26/2021 PROVIDED BY STRUCTURAL METAL FABRICATORS, INC. TRUCK EQUIPMENT DUMP, PLOW, SALTER, HYDRAULICS, LIGHTS  AS PER QUOTES DATED, 5/26/21 AND 6/1/21 PER STATE CONTRACT NO. 17-FLEET-00241  PER RESOLUTION NO.	1-01-44-900-003-000	92,858.0000	185,716.00
			TOTAL	185,716.00

Introduced on: August 10, 2021  
 Adopted on: August 10, 2021  
 Official Resolution#: R20210746

REQUESTING DEPARTMENT

DATE

Proposal Bid/No Bid Assessment and Checklist

92,858

PASSAIC COUNTY 2022 NJ STATE CONTRACT 17-FLEET-00241 06/01/21

2021/2022 NJ STATE CONTRACT 17-FLEET-00241 SUPER DUTY 4X4 VALID 08/17/2017 TO 8/16/2021

PLEASE ADD OPTIONS TO THE RIGHT AFTER SELECTING OPTION VIA DROP DOWN MENU

ROUTE 23 AUTOMALL LLC  
1301 ROUTE 23  
BUTLER, NJ 07405

Base bid price

Contact David Armiger 908-872-0867 damiger@23automall.com

DEALER PRICE	YOUR PRICE
103,640	92,858.00

USE DI  
BY CLI  
TO RIC  
PLEAS  
OPTIO  
WILL E  
BOTTC

CHASSIS OPTIONS

PLEASE USE DROP DOWN MENU ON RIGHT OF LAST COLUMN TO SELECT

99Y	7.3 liter gas engine V-8	-7832	-7832	
62R	Pto Provision	320	280	
X4N	4.10 limited slip axle (REQUIRES DIESEL 99T)	420	360	
X8L	4.88 limited slip axle (REQUIRES 68M)	420	360	INCLU
X8L	4.30 limited slip axle	420	360	
475	GVWR 18,000 pounds	-422	-422	
68M	GVWR 19,500 (gas engine) double frame 19,000 GVWR 60"CA (Gas engine)	1425	1155	
THS	Tires 4 traction rear and 2 all season front tires	280	280	
TGB	Tires 4 traction rear and 2 traction front tires	385	215	
512	Spare tire and wheel mounted same as on chassis	575	473	
945	Stainless steel wheel covers set of four mounted on wheels Ford direct	595	480	
1S	Cloth seat 40/20/40 split bench seat	140	100	
LS	Vinyl 40/ mini console/40 front seat	485	355	
2S	Cloth 40/ mini console / 40 front seat	685	515	
96V	XL value cd player, mp3, 4 speakers, cruise control, chrome bumper	775	595	
67H	Power Group (Windows, Door locks, Heated Mirrors, Keyless Entry)	985	920	INCLU
535	High capacity trailer tow package (68M required as well) Chassis Only	835	665	
98G	CNG / LPG fuel capable engine	420	315	
63T	Engine idle shutdown (optional, not mandatory in New Jersey)	365	290	
98R	Operator commanded regeneration (diesel only)	345	250	
67A	Dual alternators Diesel only	485	380	
213	4x4 shift on the fly	320	225	
65M	28 gallon mid ship fuel tank	245	125	
65C	Dual diesel fuel tanks 68 gallon capacity 40 gallon 28 gallon mid ship	550	380	
531	Trailer Tow Package (Package must be selected with Tow Command)	330	270	INCLU
18B	6" angular cab steps molded-in-color running boards	595	388	INCLU
41A	Rapid heat supplemental cab heater	325	250	
76S	Remote Start (requires 90L)	240	195	
91M	SYNC hands free cell phone system hardware (requires 62D)	495	395	
62D	Steering wheel audio controls (required with SYNC)	95	70	
17F	Chrome front bumper with aerodynamic headlights	160	125	
47A	Special Green Paint factory sprayed	895	820	
67P	7500 lb front axle	450	410	INCLU
98R	Diesel manual regeneration	85	45	
VS2	Super Cab	-3622	-3622	
VSO	Delete all additional equipment from NJ State	-5280	-5280	
F4H	16,000 lb. 4x4 GVW Chassis deduct from base GVWR F4H		-569	
F3H	14,000 lb. 4x4 GVW Chassis deduct from base GVWR F3H		-3384	
F3B	11,000 LB 4X4 GVW Pick Up deduct from base GVWR F3B		-4804	
2WD	2 WHEEL DRIVE IN LIEU OF 4X4 CHASSIS ONLY		-2739	
203	203 Wheel are 24.5 GA	588	488	

EQUIPMENT OPTIONS

PL1C	TRUCK EQUIPMENT DUMP, PLOW, SALTER, HYDRAULICS, LIGHTS	42,380.00	42,380.00
WA	7 YEAR 100,000 MILE WARRANTY TO COVER ALL MAJOR COMPONENTS		

**PASSAIC COUNTY 2022 NJ STATE CONTRACT 17-FLEET-00241 06/01/21**

2021/2022 NJ STATE CONTRACT 17-FLEET-00241 SUPER DUTY 4X4 VALID 08/17/2017 TO 01/16/2021

PLEASE ADD OPTIONS TO THE RIGHT AFTER SELECTING OPTION VIA DROP DOWN MENU

ROUTE 23 AUTOMALL LLC  
1301 ROUTE 23  
BUTLER, NJ 07405  
Revs bid price  
Contact: David Armiger 908-872-0867, darmiger@23automall.com

DEALER PRICE	YOUR PRICE
103,640	92,858.00

USE DROP DOWN MENU BY CLICKING ON ROW TO RIGHT OF COLUMN. PLEASE SELECT EACH OPTION NEEDED. TOTAL WILL BE TALLIED ON BOTTOM OF PAGE

**CHASSIS OPTIONS**

PLEASE USE DROP DOWN MENU ON RIGHT OF LAST COLUMN TO SELECT

Code	Description	Dealer Price	Your Price	Included
99V	7.3 liter gas engine V-8	-7832	-7832	
52R	Pro Provision	320	280	
X4N	4.10 limited slip axle (REQUIRES DIESEL 99T)	420	360	
X6	4.65 limited slip axle (REQUIRES 68M)	420	360	INCLUDED
X8L	4.30 limited slip axle	420	360	
475	GVWR 18,000 pounds	-422	-422	
68M	GVWR 19,500 (gas engine) double frame 19,500 GVWR 60" CA (Gas engine)	1425	1155	
T1B	Tires 4 traction rear and 2 all season front tires	280	280	
TGB	Tires 4 traction rear and 2 traction front tires	385	215	
512	Spare tire and wheel mounted same as on chassis	575	473	
945	Stainless steel wheel covers set of four mounted on wheels Ford direct	595	480	
16	Cloth seat 40/20/40 split bench seat	140	100	
LS	Vinyl 40/ mini console/40 front seat	485	355	
2S	Cloth 40/ mini console/40 front seat	685	515	
96V	XL value cd player, mp3, 4 speakers, cruise control, chrome bumper	775	585	
67H	Power Group (Windows, Door locks, Heated Mirrors, Keyless Entry)	985	920	INCLUDED
935	High capacity trailer tow package (68M required as well) Chassis Only	835	665	
98G	CNG / LPG fuel capable engine	420	315	
631	Engine idle shutdown (optional and mandatory in New Jersey)	365	290	
98R	Operator commanded regeneration (diesel only)	345	280	
67A	Dual alternators Diesel only	485	380	
213	4x4 shift on the fly	325	225	
65M	28 gallon mid ship fuel tank	245	125	
65C	Dual diesel fuel tanks 68 gallon capacity 40 gallon 28 gallon mid ship	550	380	
531	Trailer Tow Package (Package must be selected with Tow Command)	330	270	INCLUDED
18B	6" angular cab steps molded-in-color running boards	595	388	INCLUDED
41A	Rapid heat supplemental cab heater	325	250	
76S	Remote Start (requires 90L)	240	195	
91M	SYNC hands free cellphone system hardware (requires 62D)	495	395	
62D	Steering wheel audio controls (required with SYNC)	85	70	
17F	Chrome front bumper with aerodynamic headlights	160	125	
47A	Special Green Paint factory sprayed	895	820	
67P	7500 lb front axle	450	410	INCLUDED
98R	Diesel manual regeneration	85	45	
V52	Super Cab	-3522	-3522	
V5D	Delete all additional equipment from NJ State	-5280	-5280	
F4R	16,000 lb 4x4 GVW Chassis deduct from base GVWR F4R		-559	
F3H	14,000 lb 4x4 GVW Chassis deduct from base GVWR F3H		-3384	
F3B	11,000 lb 4x4 GVW Chassis deduct from base GVWR F3B		-4604	
ZWD	2 WHEEL DRIVE IN LIEU OF 4X4 CHASSIS ONLY		-2735	
WB	203 Wheelbase 64" CA	588	488	488.00

**EQUIPMENT OPTIONS**

PL1C	TRUCK EQUIPMENT DUMP, PLOW, SALTER, HYDRAULICS, LIGHTS	42,380.00	42,380.00	42,380.00
WA1	7 YEAR 100,000 MILE BUMPER TO BUMPER WARRANTY CHASSIS	6290	5922	
WA2	6 YEAR 100,000 MILE BUMPER TO BUMPER WARRANTY CHASSIS	6035	5735	
WA3	5 YEAR 75000 MILE BUMPER TO BUMPER WARRANTY CHASSIS	4300	3820	

ROUTE 23 AUTOMALL IS A NJ STATE PARTS AND SERVICE CONTRACT VENDOR

TOTAL COST OF UNIT BASE PRICE AND OPTIONS: 92,858.00  
PURCHASE ORDERS TO: darmiger@23automall.com OR FAX TO 973-936-5572  
CELL: 908-872-0867 OFFICE 973-833-0800 x122

\* options are available to members for additional cost not included in base bid

**NJ STATE CONTRACT 17-FLEET-00241 SUPER DUTY UNIVERSAL TRUCK 4X4**



David Armiger  
Commercial/Municipal Truck Manager

darmiger@23automall.com  
http://www.23ford.com/

Route 23 Automall  
1301 Route 23  
BUTLER, NJ 07405

(973) 838-0800 ext. 122 direct line  
(908) 872-0867 cellular  
(973) 838-5572 fax

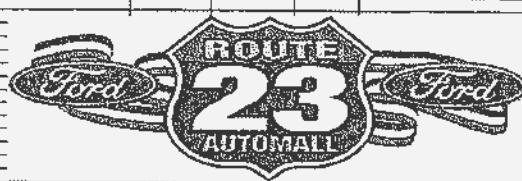

Prepared for: Mr. Dan Garafano

Sales Consultant, SMF

Prepared by: Dave Armiger

06/01/2021

NJ STATE CONTRACT | CONTRACT 17-FLEET-00241 Butler New Jersey | 07405



2022 F-550 Chassis 4x4 SD Crew Cab 203" WB DRW XL (W5H)

Price Level: 225 | Quote ID: PASSW5HNJ

## Table of Contents

Description	Page
Table of Contents.....	1
Selected Equip & Specs.....	2
As Configured Vehicle.....	12

**Prepared for: Mr. Dan Garafano**

Sales Consultant, SMF

Prepared by: Dave Armiger

06/01/2021

NJ STATE CONTRACT | CONTRACT 17-FLEET-00241 Butler New Jersey | 07405



2022 F-550 Chassis 4x4 SD Crew Cab 203" WB DRW XL (W5H)

Price Level: 225 | Quote ID: PASSW5HNJ

## Selected Equip & Specs

### Dimensions

• Exterior length: 289.2" • Cab to axle: 84.0" • Exterior width: 80.0" • Exterior height: 81.7" • Wheelbase: 203.0" • Front track: 74.8" • Rear track: 74.0" • Turning radius: 28.6' • Rear tire outside width: 93.9" • Min ground clearance: 8.2" • Front legroom: 43.9" • Rear legroom: 43.6" • Front headroom: 40.8" • Rear headroom: 40.4" • Front hiproom: 62.5" • Rear hiproom: 64.7" • Front shoulder room: 66.7" • Rear shoulder room: 65.9" • Passenger volume: 131.7cu.ft. • Cargo volume: 52.1cu.ft. • Maximum cargo volume: 52.1cu.ft.

### Powertrain

• 350hp 7.3L OHV 16 valve V-8 engine with DEVCT variable valve control, SMPI • Recommended fuel : regular unleaded • federal • TorqShift 10 speed automatic transmission with overdrive • Part-time \* **Limited slip differential** • Fuel Economy City: N/A • Fuel Economy Highway: N/A \* **Transmission PTO provision**

### Suspension/Handling

• Front Mono-beam non-independent suspension with anti-roll bar, HD shocks \* **Rear DANA 130 rigid axle leaf spring suspension with anti-roll bar, HD shocks** • Firm ride Suspension • Hydraulic power-assist re-circulating ball Steering • Front and rear 19.5 x 6 argent steel wheels \* **LT225/70SR19.5 GBSW AT front and rear tires** • Dual rear wheels

### Body Exterior

• 4 doors • Conventional left rear passenger • Conventional right rear passenger \* **Driver and passenger power remote heated, manual folding door mirrors with turn signal indicator** \* **Turn signal indicator in mirrors** • Black door mirrors • Black bumpers \* **Side steps** • Trailer harness • Clearcoat paint • Front and rear 19.5 x 6 wheels • 2 front tow hook(s)

### Convenience

• Manual air conditioning with air filter \* **Power windows** \* **Driver and passenger 1-touch up** \* **Driver and passenger 1-touch down** \* **Remote power door locks with 2 stage unlock and illuminated entry** • Manual tilt steering wheel • Manual telescopic steering wheel • Day-night rearview mirror • FordPass Connect 4G internet access • 911 Assist emergency SOS • Wireless phone connectivity • AppLink smart device integration • 2 1st row LCD monitors • Front and rear cupholders • Passenger visor mirror • Full overhead console \* **Driver and passenger door bins** \* **Rear door bins** • Upfitter switches

### Seats and Trim

• Seating capacity of 6 • Front 40-20-40 split-bench seat • 4-way driver seat adjustment • Manual driver lumbar support • 4-way passenger seat adjustment • Centre front armrest with storage • 60-40 folding rear split-bench seat

### Entertainment Features

• AM/FM stereo radio • SYNC external memory control • Steering wheel mounted radio controls • 4 speakers • Streaming audio • Fixed antenna

### Lighting, Visibility and Instrumentation

Prices and contents availability are subject to change and should be treated as estimates only. Actual base vehicle, package and option pricing may vary from this quote due to special local pricing, availability or pricing adjustments not reflected in the dealer's computer system. See Official Resolution # R20210746 for more information.

Prepared for: Mr. Dan Garafano

Sales Consultant, SMF

Prepared by: Dave Armiger

06/01/2021

NJ STATE CONTRACT | CONTRACT 17-FLEET-00241 Butler New Jersey | 07405



2022 F-550 Chassis 4x4 SD Crew Cab 203" WB DRW XL (W5H)

Price Level: 225 | Quote ID: PASSW5HNJ

## Selected Equip & Specs (cont'd)

• Halogen aero-composite headlights • Delay-off headlights • Auto on/off headlights • Variable intermittent front windshield wipers • Light tinted windows • Front and rear reading lights • Tachometer • Oil pressure gauge • Compass • Outside temperature display • Trip computer • Trip odometer

### Safety and Security

• 4-wheel ABS brakes • Brake assist • 4-wheel disc brakes • Driveline traction control • Dual front impact airbag supplemental restraint system • Dual seat mounted side impact airbag supplemental restraint system • Safety Canopy System curtain 1st and 2nd row overhead airbag supplemental restraint system • **Remote activated perimeter/approach lighting** • **Power remote door locks with 2 stage unlock and panic alarm** • **Security system with SecuriLock immobilizer** • **MyKey restricted driving mode** • Manually adjustable front head restraints • 3 manually adjustable rear head restraints

### Dimensions

#### General Weights

* Curb .....	7,809 lbs.	* GVWR .....	19,500 lbs.
* Payload .....	11,900 lbs.		

#### Front Weights

* Front GAWR .....	7,500 lbs.	* Front curb weight .....	4,469 lbs.
* Front axle capacity .....	7,500 lbs.	* Front spring rating .....	7,500 lbs.
Front tire/wheel capacity .....	7,500 lbs.		

#### Rear Weights

* Rear GAWR .....	14,706 lbs.	* Rear curb weight .....	3,340 lbs.
* Rear axle capacity .....	14,706 lbs.	* Rear spring rating .....	15,000 lbs.
Rear tire/wheel capacity .....	15,000 lbs.		

#### Trailer Type

Harness .....	Yes	* Brake controller .....	Yes
Trailer sway control .....	Yes		

#### General Trailering

5th-wheel towing capacity .....	19300 lbs.	Gooseneck towing capacity .....	19300 lbs.
Towing capacity .....	18340 lbs.	GCWR .....	28000 lbs.

#### Fuel Tank type

Capacity .....

40 gal.
---------

#### Off Road

Min ground clearance .....

8 "
-----

#### Interior cargo

Cargo volume .....	52.1 cu.ft.	Maximum cargo volume .....	52.1 cu.ft.
--------------------	-------------	----------------------------	-------------

Prices and content availability shown are subject to change and should be treated as estimates only. Actual base vehicle, package and option pricing may vary from this quote due to special local pricing, availability or pricing adjustments not reflected in the dealer's computer system. See Official Representative for more information.



**Prepared for: Mr. Dan Garafano**

Sales Consultant, SMF

Prepared by: Dave Anniger

06/01/2021

NJ STATE CONTRACT | CONTRACT 17-FLEET-00241 Butler New Jersey | 07405



2022 F-550 Chassis 4x4 SD Crew Cab 203" WB DRW XL (W5H)

Price Level: 225 | Quote ID: PASSW5HNJ

**Selected Equip & Specs (cont'd)***Rear Frame*

Height loaded .....	29 "	Height unloaded .....	34 "
---------------------	------	-----------------------	------

**Powertrain***Engine Type*

Block material .....	Iron	Cylinders .....	V-8
Head material .....	Aluminum	Ignition .....	Spark
Injection .....	Sequential MPI	Liters .....	7.3L
Orientation .....	Longitudinal	Recommended fuel .....	Regular unleaded
Valves per cylinder .....	2	Valvetrain .....	OHV
Variable valve control .....	DEVCT		

*Engine Spec*

Bore .....	4.21"	Compression ratio .....	10.5:1
Displacement .....	445 cu.in.	Stroke .....	3.98"

*Engine Power*

SAEJ1349 AUG2004 compliant .....	Yes	Output .....	350 HP @ 3,900 RPM
Torque .....	468 ft.-lb @ 3,900 RPM		

*Alternator*

*Type .....	Dual	*Amps .....	397
-------------	------	-------------	-----

*Battery*

Amp hours .....	78	Cold cranking amps .....	750
Run down protection .....	Yes	*Type .....	Dual

*Transmission*

Electronic control .....	Yes	Lock-up .....	Yes
Overdrive .....	Yes	Speed .....	10
Type .....	Automatic		

*Transmission Gear Ratios*

1st .....	4.696	2nd .....	2.985
3rd .....	2.146	4th .....	1.769
5th .....	1.52	6th .....	1.275
7th .....	1	8th .....	0.854
9th .....	0.689	10th .....	0.616
Reverse Gear ratios .....	4.866		

*Transmission Extras*

Driver selectable mode .....	Yes	Sequential shift control .....	SelectShift
Oil cooler .....	Regular duty	*PTO provision .....	Yes

Prices and contents availability shown are subject to change and should be treated as estimates only. Actual base vehicle, package and option pricing may vary from this quote due to special local pricing, availability or pricing adjustments not reflected in the dealer's computer system. See Official Resolution # R20210746 for more information.

Prepared for: Mr. Dan Garafano

Sales Consultant, SMF

Prepared by: Dave Armiger

06/01/2021

NJ STATE CONTRACT | CONTRACT 17-FLEET-00241 Butler New Jersey | 07405

2022 F-550 Chassis 4x4 SD Crew Cab 203" WB DRW XL (W5H)

Price Level: 225 | Quote ID: PASSW5HNJ



## Selected Equip & Specs (cont'd)

### Drive Type

4wd type ..... Part-time      Type ..... Four-wheel

### Drive Feature

\* Limited slip differential ..... **Mechanical**      Traction control ..... Driveline  
 \* Power take-off provision ..... **Yes**      Locking hub control ..... Auto  
 Transfer case shift ..... **Electronic**

### Drive Axle

Ratio ..... 4.88

### Exhaust

Material ..... Stainless steel      System type ..... Single

### Emissions

CARB ..... Federal

### Fuel Economy

Fuel type ..... Gasoline

## Driveability

### Brakes

ABS ..... 4-wheel      ABS channels ..... 3  
 Type ..... 4-wheel disc      Vented discs ..... Front and rear

### Brake Assistance

Brake assist ..... Yes

### Suspension Control

Ride ..... Firm

### Front Suspension

Independence ..... Mono-beam non-independent      Anti-roll bar ..... Regular

### Front Spring

Type ..... Coil      \* Grade ..... **HD**

### Front Shocks

Type ..... HD

### Rear Suspension

\* Independence ..... **DANA 130 rigid axle**      Type ..... Leaf

Anti-roll bar ..... Regular

### Rear Spring

Type ..... Leaf      Grade ..... HD

Prices and content available only in NJ are subject to change and should be treated as estimates only. Actual base vehicle, package and option pricing may vary from this listing due to special local pricing, availability or pricing adjustments not reflected in the dealer's computer system. See Official Report for the most current information.

Prepared for: Mr. Dan Garafano

Sales Consultant, SMF

Prepared by: Dave Armiger

06/01/2021

NJ STATE CONTRACT | CONTRACT 17-FLEET-00241 Butler New Jersey | 07405



2022 F-550 Chassis 4x4 SD Crew Cab 203" WB DRW XL (W5H)

Price Level: 225 | Quote ID: PASSW5HNJ

### Selected Equip & Specs (cont'd)

*Rear Shocks*

Type ..... HD

*Steering*

Activation ..... Hydraulic power-assist      Type ..... Re-circulating ball

*Steering Specs*

# of wheels ..... 2

### Exterior

*Front Wheels*

Diameter ..... 19.5"      Width ..... 6.00"

*Rear Wheels*

Diameter ..... 19.5"      Width ..... 6.00"

Dual ..... Yes

*Spare Wheels*

\* Wheel material ..... Steel

*Front and Rear Wheels*

Appearance ..... Argent      Material ..... Steel

*Front Tires*

Aspect ..... 70      Diameter ..... 19.5"

Sidewalls ..... BSW      Speed ..... S

\* Tread ..... AT      Type ..... LT

Width ..... 225mm      LT load rating ..... G

\* RPM ..... 645

*Rear Tires*

Aspect ..... 70      Diameter ..... 19.5"

Sidewalls ..... BSW      Speed ..... S

\* Tread ..... AT      Type ..... LT

Width ..... 225mm      LT load rating ..... G

\* RPM ..... 645

*Spare Tire*

\* Mount ..... Frame mounted      \* Type ..... Full-size

*Wheels*

Front track ..... 74.8"      Rear track ..... 74.0"

Turning radius ..... 28.6'      Wheelbase ..... 203.0"

Rear tire outside width ..... 93.9"

Prices and content availability as shown are subject to change and should be treated as estimates only. Actual base vehicle, package and option pricing. Adopted from this page 10/2021 of special local pricing, availability or pricing adjustments not reflected in the dealer's computer system. See Official Resolution for the most current information.

Prepared for: Mr. Dan Garafano

Sales Consultant, SMF

Prepared by: Dave Armiger

06/01/2021

NJ STATE CONTRACT | CONTRACT 17-FLEET-00241 Buffer New Jersey | 07405

2022 F-550 Chassis 4x4 SD Crew Cab 203" WB DRW XL (W5H)

Price Level: 225 | Quote ID: PASSW5HNJ



## Selected Equip & Specs (cont'd)

### Body Features

* Front license plate bracket .....	Yes	Front splash guards .....	Yes
Body material .....	Aluminum	Side impact beams .....	Yes
* Side steps .....	Yes	Front tow hook(s) .....	2

### Body Doors

Door count .....	4	Left rear passenger .....	Conventional
Right rear passenger .....	Conventional		

### Exterior Dimensions

Length .....	289.2"	Body width .....	80.0"
Body height .....	81.7"	Cab to axle .....	84.0"
Axle to end of frame .....	47.2"	Frame section modulus .....	12.7cu.in.
Frame yield strength (psi) .....	50000.0	Frame rail width .....	34.2"
Front bumper to Front axle .....	38.3"	Cab to end of frame .....	131.2"
Front bumper to back of cab .....	158.1"		

## Safety

### Airbags

Driver front-impact .....	Yes	Driver side-impact .....	Seat mounted
Overhead ... Safety Canopy System curtain 1st and 2nd row		Passenger front-impact .....	Yes
Passenger side-impact .....	Seat mounted		

### Seatbelt

Height adjustable .....	Front
-------------------------	-------

### Security

* Immobilizer .....	SecuriLock	* Panic alarm .....	Yes
* Restricted driving mode .....	MyKey		

## Seating

### Passenger Capacity

Capacity .....	6
----------------	---

### Front Seats

Split .....	40-20-40	Type .....	Split-bench
-------------	----------	------------	-------------

### Driver Seat

Fore/aft .....	Manual	Reclining .....	Manual
Way direction control .....	4	Lumbar support .....	Manual

### Passenger seat

Prices and content availability as shown are subject to change and should be treated as estimates only. Actual base vehicle, package and option pricing may vary from this figure due to special local pricing, availability or pricing adjustments not reflected in the dealer's computer system. See Official Representative for the most current information.

Prepared for: Mr. Dan Garafano

Sales Consultant, SMF

Prepared by: Dave Armiger

06/01/2021

NJ STATE CONTRACT | CONTRACT 17-FLEET-00241 Butler New Jersey | 07405



2022 F-550 Chassis 4x4 SD Crew Cab 203" WB DRW XL (W5H)

Price Level: 225 | Quote ID: PASSW5HNJ

**Selected Equip & Specs (cont'd)**

Fore/aft	Manual	Reclining	Manual
Way direction control	4		
<b>Front Head Restraint</b>			
Control	Manual	Type	Adjustable
<b>Front Armrest</b>			
Centre	Yes	Storage	Yes
<b>Rear Seats</b>			
Descriptor	Split-bench	Facing	Front
Folding	60-40	Folding position	Fold-up cushion
Type	Fixed		
<b>Rear Head Restraints</b>			
Control	Manual	Type	Adjustable
Number	3		
<b>Front Seat Trim</b>			
Material	Vinyl	Back material	Vinyl
<b>Rear Seat Trim Group</b>			
Material	Vinyl	Back material	Carpet

**Convenience**

<b>AC And Heat Type</b>			
Air conditioning	Manual	Air filter	Yes
Underseat ducts	Yes		
<b>Audio System</b>			
Radio	AM/FM stereo	Radio grade	Regular
Seek-scan	Yes	External memory control	SYNC
<b>Audio Speakers</b>			
Speaker type	Regular	Speakers	4
<b>Audio Controls</b>			
Steering wheel controls	Yes	Voice activation	Yes
Streaming audio	Bluetooth yes		
<b>Audio Antenna</b>			
Type	Fixed		
<b>LCD Monitors</b>			
1st row	2	Primary monitor size (inches)	4.2
<b>Convenience Features</b>			

Prices and content availability shown are subject to change and should be treated as estimates only. Actual base vehicle, package and option pricing may vary from this quote due to special local pricing, availability or pricing adjustments not reflected in the dealer's computer system. See Official Representative for the most current information.

**Prepared for: Mr. Dan Garafano**

Sales Consultant, SMF  
 Prepared by: Dave Armiger  
 06/01/2021



NJ STATE CONTRACT | CONTRACT 17-FLEET-00241 Butler New Jersey | 07405

**2022 F-550 Chassis 4x4 SD Crew Cab 203" WB DRW XL (W5H)**

Price Level: 225 | Quote ID: PASSW5HNJ

**Selected Equip & Specs (cont'd)**

*Retained accessory power	Yes	12V DC power outlet	3
Emergency SOS	911 Assist	Wireless phone connectivity	Bluetooth
Smart device integration	App link	Upfitter switches	Yes
<b>Door Lock Activation</b>			
*Type	Power with 2 stage unlock	*Remote	Keyfob (all doors)
*Integrated key/remote	Yes		
<b>Door Locks Extra FOB Controls</b>			
Remote engine start	Smart device only		
<b>Instrumentation Type</b>			
Appearance	Analog		
<b>Instrumentation Gauges</b>			
Tachometer	Yes	Oil pressure	Yes
Engine temperature	Yes	Transmission fluid temp	Yes
Engine hour meter	Yes		
<b>Instrumentation Warnings</b>			
Oil pressure	Yes	Engine temperature	Yes
Battery	Yes	Lights on	Yes
Key	Yes	Low fuel	Yes
Door ajar	Yes	Service interval	Yes
Brake fluid	Yes		
<b>Instrumentation Displays</b>			
Clock	In-radio display	Compass	Yes
Exterior temp	Yes	Systems monitor	Yes
<b>Instrumentation Feature</b>			
Trip computer	Yes	Trip odometer	Yes
<b>Steering Wheel Type</b>			
Material	Urethane	Tilting	Manual
Telescoping	Manual		
<b>Front Side Windows</b>			
*Window 1st row activation	Power		
<b>Windows Rear Side</b>			
*2nd row activation	Power		
<b>Window Features</b>			
*1-touch down	Driver and passenger	*1-touch up	Driver and passenger
Tinted	Light		

Prices and content availability as shown are subject to change and should be treated as estimates only. Actual base vehicle, package and option pricing may vary from this quote. Prices are subject to change without notice. Official Ford website for the most current information. Adopted from this August 10, 2021. August 10, 2021. August 10, 2021. August 10, 2021.

Prepared for: Mr. Dan Garafano

Sales Consultant, SMF

Prepared by: Dave Arniger

06/01/2021

NJ STATE CONTRACT | CONTRACT 17-FLEET-00241 Butler New Jersey | 07405



2022 F-550 Chassis 4x4 SD Crew Cab 203" WB DRW XL (W5H)

Price Level: 225 | Quote ID: PASSW5HNJ

### Selected Equip & Specs (cont'd)

*Front Windshield*

Wiper ..... Variable intermittent

*Rear Windshield*

Window ..... Fixed

### Interior

*Passenger Visor*

Mirror ..... Yes

*Rear View Mirror*

Day-night ..... Yes

*Headliner*

Coverage ..... Full      Material ..... Cloth

*Floor Trim*

Coverage ..... Full      Covering ..... Vinyl/rubber

*Trim Feature*

Gear shifter material ..... Urethane      Interior accents ..... Chrome

*Lighting*

Dome light type ..... Fade      Front reading ..... Yes

\*Illuminated entry ..... Yes      Rear reading ..... Yes

Variable IP lighting ..... Yes

*Overhead Console Storage*

Storage ..... Yes      Type ..... Full

*Storage*

\* Driver door bin ..... Yes      Front Beverage holder(s) ..... Yes

Glove box ..... Locking      \* Passenger door bin ..... Yes

\* Seatback storage pockets ..... 2      Illuminated ..... Yes

Rear yes ..... Yes      Instrument panel ..... Covered bin

Dashboard ..... Yes      \* Rear door bins ..... Yes

*Legroom*

Front ..... 43.9"      Rear ..... 43.6"

*Headroom*

Front ..... 40.8"      Rear ..... 40.4"

*Hip Room*

Front ..... 62.5"      Rear ..... 64.7"

Prices and content availability shown are subject to change and should be treated as estimates only. Actual base vehicle, package and option pricing may vary from this August 10, 2021 of special local pricing, availability or pricing adjustments not reflected in the dealer's computer system. See Official Resolution # R20210749 for more information.

Prepared for: Mr. Dan Garafano

Sales Consultant, SMF

Prepared by: Dave Armiger

06/01/2021

NJ STATE CONTRACT | CONTRACT 17-FLEET-00241 Butler New Jersey | 07405



2022 F-550 Chassis 4x4 SD Crew Cab 203" WB DRW XL (W5H)

Price Level: 225 | Quote ID: PASSW5HNJ

### Selected Equip & Specs (cont'd)

*Shoulder Room*

Front ..... 66.7"                      Rear ..... 65.9"

*Interior Volume*

Passenger volume ..... 131.7 cu.ft.

Price and content availability as shown are subject to change and should be treated as estimates only. Actual base vehicle, package and option pricing may vary from this estimate because of special local pricing, availability or pricing adjustments not reflected in the dealer's computer system. See salesperson for the most current information.



**Prepared for: Mr. Dan Garafano**

Sales Consultant, SMF

Prepared by: Dave Armiger

06/01/2021

NJ STATE CONTRACT | CONTRACT 17-FLEET-00241 Butler New Jersey | 07405



2022 F-550 Chassis 4x4 SD Crew Cab 203" WB DRW XL (W5H)

Price Level: 225 | Quote ID: PASSW5HNJ

**As Configured Vehicle**

Code	Description
<b>Base Vehicle</b>	
W5H	Base Vehicle Price (W5H)
<b>Packages</b>	
660A	<p>Order Code 660A</p> <p><i>Includes:</i></p> <ul style="list-style-type: none"> <li>- Engine: 7.3L 2V DEVCT NA PFI V8 Gas</li> <li>- Transmission: TorqShift 10-Speed Automatic 10R140 with neutral idle and selectable drive modes: normal, tow/haul, eco, deep sand/snow and slippery.</li> <li>- Wheels: 19.5" x 6" Argent Painted Steel Hub covers/center ornaments not included.</li> <li>- HD Vinyl 40/20/40 Split Bench Seat Includes center armrest, cupholder, storage and driver's side manual lumbar.</li> <li>- Radio: AM/FM Stereo w/MP3 Player Includes 6 speakers.</li> <li>- SYNC Communications &amp; Entertainment System Includes enhanced voice recognition, 911 Assist, 4.2" LCD center stack screen, AppLink, 1 smart-charging USB port and steering wheel audio controls.</li> </ul>
<b>Powertrain</b>	
99N	Engine: 7.3L 2V DEVCT NA PFI V8 Gas
44G	<p>Transmission: TorqShift 10-Speed Automatic</p> <p>10R140 with neutral idle and selectable drive modes: normal, tow/haul, eco, deep sand/snow and slippery.</p>
X8L	Limited Slip w/4.88 Axle Ratio
68M	<p>GVWR: 19,500 lb Payload Plus Upgrade Package</p> <p>Includes upgraded frame, rear-axle and low deflection/high capacity springs. Increases max RGAWR to 14,706. Note: See Order Guide Supplemental Reference for further details on GVWR.</p>
<b>Wheels &amp; Tires</b>	
TGK	<p>Tires: 225/70Rx19.5G BSW Traction (TGK)</p> <p>Includes 4 traction tires on the rear and 2 traction tires on the front. Not recommended for over the road applications; could incur irregular front tire wear and/or NVH.</p>
64Z	<p>Wheels: 19.5" x 6" Argent Painted Steel</p> <p>Hub covers/center ornaments not included.</p>
512	<p>Spare Tire, Wheel &amp; Jack</p> <p>Required in Rhode Island.</p> <p><i>Excludes carrier.</i></p> <p><i>Includes:</i></p> <ul style="list-style-type: none"> <li>- 6-Ton Hydraulic Jack</li> </ul>

Prices and content availability as shown are subject to change and should be treated as estimates only. Actual base vehicle, package and option pricing may vary from this quote due to special local pricing, availability or pricing adjustments not reflected in the dealer's computer system. See Official Publication for the most current information.

Prepared for: Mr. Dan Garafano

Sales Consultant, SMF

Prepared by: Dave Armiger

06/01/2021

NJ STATE CONTRACT | CONTRACT 17-FLEET-00241 Butler New Jersey | 07405



2022 F-550 Chassis 4x4 SD Crew Cab 203" WB DRW XL (W5H)

Price Level: 225 | Quote ID: PASSW5HNJ

## As Configured Vehicle (cont'd)

Code	Description
<b>Seats &amp; Seat Trim</b>	
A	HD Vinyl 40/20/40 Split Bench Seat <i>Includes center armrest, cupholder, storage and driver's side manual lumbar.</i>
<b>Other Options</b>	
PAINT	Monotone Paint Application
203WB	203" Wheelbase
STDRD	Radio: AM/FM Stereo w/MP3 Player <i>Includes 6 speakers.</i> <i>Includes:</i> - SYNC Communications & Entertainment System <i>Includes enhanced voice recognition, 911 Assist, 4.2" LCD center stack screen, AppLink, 1 smart-charging USB port and steering wheel audio controls.</i>
90L	Power Equipment Group <i>Deletes passenger side lock cylinder. Includes upgraded door-trim panel.</i> <i>Includes:</i> - Accessory Delay - Advanced Security Pack <i>Includes SecurILock Passive Anti-Theft System (PATS) and inclination/intrusion sensors.</i> - Folding Trailer Tow Mirrors w/Power Heated Glass <i>Includes manual telescoping, heated convex spoiler mirror and integrated clearance lamps/turn signals.</i> - MyKey <i>Includes owner controls feature.</i> - Power Front & Rear Side Windows <i>Includes 1-touch up/down driver/passenger window.</i> - Power Locks - Remote Keyless Entry
67P	Extra Heavy-Duty Front End Suspension - 7,500 GAWR <i>Includes upgraded front axle and max 7,500 lbs. Front springs/GAWR rating for configuration selected. Incomplete vehicle package - requires further manufacture and certification by a final stage manufacturer.</i>
473	Snow Plow Prep Package <i>Includes pre-selected springs (see order guide supplemental reference for springs/GAWR of specific vehicle configurations). Note 1: Restrictions apply; see supplemental reference or body builders layout book for details. Note 2: Also allows for the attachment of a winch. Note 3: Highly recommended to add (86M) dual battery on 7.3L gas engines. Adding (67B) 397 amp alternators for diesel engine is highly recommended for max output.</i>
61J	6-Ton Hydraulic Jack
62R	Transmission Power Take-Off Provision <i>Includes mobile and stationary PTO modes.</i>
86M	Dual 78 AH Battery

Prices and content availability as shown are subject to change and should be treated as estimates only. Actual base vehicle, package and option pricing may vary from this estimate because of special local pricing, availability or pricing adjustments not reflected in the dealer's computer system. See Official Resources for more information.

Prepared for: Mr. Dan Garafano

Sales Consultant, SMF

Prepared by: Dave Arnlger

06/01/2021

NJ STATE CONTRACT | CONTRACT 17-FLEET-00241 Butler New Jersey | 07405

2022 F-550 Chassis 4x4 SD Crew Cab 203" WB DRW XL (W5H)

Price Level: 225 | Quote ID: PASSW5HNJ



## As Configured Vehicle (cont'd)

Code	Description
67B	397 Amp Alternators
63A	Utility Lighting System <i>Includes LED side-mirror spotlights.</i>
52B	Trailer Brake Controller <i>Includes smart trailer tow connector. Verified to be compatible with electronic actuated drum brakes only.</i>
18B	Platform Running Boards
59H	Center High-Mounted Stop Lamp (CHMSL)
153	Front License Plate Bracket Standard in states requiring 2 license plates and optional to all others.

## Emissions

425 50-State Emissions System

## Interior Color

AS\_01 Medium Earth Gray

## Exterior Color

Z1\_01 Oxford White

Prices and content availability as shown are subject to change and should be treated as estimates only. Actual base vehicle, package and option pricing may vary from this estimate because of special local pricing, availability or pricing adjustments not reflected in the dealer's computer system. See salesperson for the most current information.

Introduced on: August 10, 2021  
 Adopted on: August 10, 2021  
 Official Resolution#: R20210748

CUSTOM METAL FABRICATION  
FIELD MAINTENANCE AND INSTALLATION  
TRUCK BODIES AND EQUIPMENT  
AERIAL AND UTILITY EQUIPMENT  
PAINTING, REPAIRS AND SERVICE



*We Build Solutions*

1226 LITTLE GAP ROAD  
PALMERTON, PA 18071  
TMERTZ@SMFTRUCK.COM  
PHONE :610-824-7000

SALES - ESTIMATING - OFFICE FAX :610-824-7100

Date : 5/26/2021

Company : Route 23 Auto Mall / Passaic County  
1301 Rt. 23  
Butler, N.J. 07405  
Phone: 973-838-0800 Ext # 122  
Cell: 908-872-0867  
Email: darmiger@23automall.com  
Attn : Dave Armiger  
Quote # 21-0056

**RE: Provide and install a Galion Model 133USD-9' Stainless Steel dump body , on to customer supplied 2022 Ford F-550 , crew cab, Gas engine , Auto Trans , 60" CA , Dual Rear Wheel .**

**Body info :**

**108" long**

**84" wide**

**18" Side Height**

**Front height 24"**

**Rear height 24"**

**Construction floor 7 Ga. 304-2B S/S**

**Sides ,front and gate 10 Ga. 304-2B S/S**

**One coal door center of gate .**

**3/16" X 7" formed long sills .**

**½ X 84" Cab Guard.**

**2- Step slide out S/S ladder .**

**Grab handle left front by ladder.**

**Model # CS615T-09' Scissor hoist in sub frame w/ Electric D/A hydraulics.**

**Provide Buyers DTR7012 Manual Tarp system .**

**Provide 18 X 18X30 Aluminum Diamond Plate underbody box.**

**Hitch plate with combo ball and pintle hook .**

**7 pin round trailer connector .**

**Provide and install a Buyers Products Model # Pro 3000 spreader install in bed of truck .**

**Provide Meyers Road pro 9' snow plow with LED lights ,Curb guards and skid shoes and deflector .**

**Provide and install Air-Lift 1000 front spring booster kit .**



COUNTY OF PASSAIC  
ROADS DEPT, CO OF PASSAIC  
(Q) 973-881-4500  
1310 ROUTE 23 NORTH  
WAYNE, NJ 07470

**Purchase Order**

THIS NUMBER MUST APPEAR ON ALL INVOICES  
PACKING LISTS, CORRESPONDENCE, ETC.

NO. 21-02929

**SHIP TO**  
COUNTY OF PASSAIC  
ROAD DEPARTMENT  
1310 ROUTE 23 NORTH  
WAYNE, NJ 07470

ORDER DATE: 05/05/21  
DELIVERY DATE:  
STATE CONTRACT: A88214  
F.O.B. TERMS:  
VENDOR ACCT NUM:  
VENDOR PHONE #:  
VENDOR FAX #:  
REQUISITION #: R1-11981

**VENDOR** Vendor #: 11508  
BEYER OF MORRISTOWN, I.L.C  
T/A BEYER CHRYSLER DODGE JEEP  
200 RIDGEDALE AVENUE  
MORRISTOWN, NJ 07960-4000

**PAYMENT RECORD**  
CHECK NO.  
DATE PAID

NOTICE: TAX EXEMPT - TAX ID: 22-6902466

QUANTITY	DESCRIPTION	ACCOUNT NO.	UNIT PRICE	TOTAL
2.00	ROAD DEPARTMENT - WAYNE TWO (2) 2022 FORD F-450 4WD REG CAB 145" WB 60", CA XL, BASE MODEL WITH FOLLOWING OPTIONS: LIMITED SLIP W/4 88 AXLE RATIO TIRES 225/70R19.5 BSW TRACTION POWER EQUIPMENT GROUP TRAILER TOW PACKAGE SNOW PLOW PRE PACKAGE DUAL 78 AH BATTERY 397 AMP ALTERNATORS GALION MODEL 133USD-9' STAINLESS STEEL DUMP BODY WITH SPREADER INSTALL IN BED OF TRUCKS  AS PER QUOTE DATED 3/18/2021  PER STATE CONTRACT NO. A88214  RESOLUTION NO. R20210428, 4/27/2021	1-01-44-900-003-000	84,278.5000	168,557.00
			<b>TOTAL</b>	<b>168,557.00</b>

*Cancelled*

<p><b>CLAIMANT'S CERTIFICATION &amp; DECLARATION</b></p> <p>I do solemnly declare and certify under penalties of the law that the within bill is correct in all its particulars; that the articles have been furnished or services rendered as stated therein; that no bonus has been given or received by any person or persons within the knowledge of this claimant in connection with the above claim; that the amount therein stated is justly due and owing; and that the amount charged is a reasonable one.</p> <p>_____ VENDOR SIGN HERE</p> <p>_____ OFFICIAL POSITION DATE</p> <p>Introduced on: August 10, 2021 Adopted on: August 10, 2021 Official Resolution: R1021029</p>	<p><b>OFFICER'S CERTIFICATION</b></p> <p>I, having knowledge of the facts, certify that the materials and supplies have been received or the services rendered; said certification being based on signed delivery slips or other reasonable procedures.</p> <p>_____ DEPT. HEAD DATE</p> <p>VENDOR MUST SIGN CERTIFICATION STATEMENT ON THIS VOUCHER. MAIL VOUCHER &amp; ITEMIZED BILLS TO: COUNTY OF PASSAIC ROADS DEPT, CO OF PASSAIC (Q) 973-881-4500 1310 ROUTE 23 NORTH WAYNE, NJ 07470</p>	<p><b>APPROVAL TO PURCHASE</b></p> <p>DO NOT ACCEPT THIS ORDER UNLESS IT IS SIGNED BELOW</p> <p><i>Sherry Anwaritakis</i> _____ Purchasing Agent, QPA</p>
---	--	---

**COUNTY OF PASSAIC**

ROADS DEPT, CO OF PASSAIC  
 (Q) 973-881-4500  
 1310 ROUTE 23 NORTH  
 WAYNE, NJ 07470

REQUISITION	
NO.	R1-11981

SHIP TO	COUNTY OF PASSAIC ROAD DEPARTMENT 1310 ROUTE 23 NORTH WAYNE, NJ 07470
VENDOR	VENDOR #: 11508 BEYER OF MORRISTOWN, LLC T/A BEYER CHRYSLER DODGE JEEP 200 RIDGEDALE AVENUE MORRISTOWN, NJ 07960-4000

ORDER DATE: 04/08/21  
 DELIVERY DATE:  
 STATE CONTRACT: A88214  
 F.O.B. TERMS:

QTY/UNIT	DESCRIPTION	ACCOUNT NO.	UNIT PRICE	TOTAL COST
2.00	ROAD DEPARTMENT - WAYNE TWO (2) 2022 FORD F-450 4WD REG CAB 145" WB 60" CA XL BASE MODEL WITH FOLLOWING OPTIONS: LIMITED SLIP W/4 88 AXLE RATIO TIRES 225/70RX19.5 BSW TRACTION POWER EQUIPMENT GROUP TRAILER TOW PACKAGE SNOW PLOW PRE PACKAGE DUAL 78 AH BATTERY 397 AMP ALTERNATORS GALION MODEL 133USD-9' STAINLESS STEEL DUMP BODY WITH SPREADER INSTALL IN BED OF TRUCKS  AS PER QUOTE DATED 3/18/2021  PER STATE CONTRACT NO. A88214  RESOLUTION NO. R20210428, 4/28/2021	1-01-44-900-003-000	84,278.5000	168,557.00
			TOTAL	168,557.00

Introduced on: August 10, 2021  
 Adopted on: August 10, 2021  
 Official Resolution#: R20210746

REQUESTING DEPARTMENT

DATE

## County of Passaic Board of County Commissioners

**OFFICE OF COUNTY COMMISSIONERS**

Director Pasquale "Pat" Lepore  
Deputy Director Bruce James  
Assad R. Akhter  
John W. Bartlett  
Theodore O. Best, Jr.  
Terry Duffy  
Cassandra "Sandi" Lazzara

401 Grand Street  
Paterson, New Jersey 07505  
Tel: 973-581-4402  
Fax: 973-742-3746

Anthony J. De Nova III  
*Administrator*  
Matthew P. Jordan, Esq.  
*County Counsel*  
Louis E. Imhof, III, RMC  
*Clerk Of The Board*



### Public Meeting (Board Meeting)

Date: Apr 27, 2021 - 5:30 PM

Location: County Administration Building  
WebEx - 220  
401 Grand Street  
Paterson, NJ 07505

Agenda: RESOLUTION AUTHORIZING THE PURCHASE OF VEHICLES FROM BEYER FORD, LLC FOR USE BY THE DIVISION OF ROADS, PURSUANT TO N.J.S.A. 40A:11-12, ET SEQ., ALL AS NOTED IN THE RESOLUTION.

THIS RESOLUTION WAS REQUESTED BY:

REVIEWED BY:

Anthony J. De Nova III  
COUNTY ADMINISTRATOR.

APPROVED AS TO FORM AND LEGALITY:

Matthew P. Jordan, Esq.  
COUNTY COUNSEL

Public Works  
COMMITTEE NAME

Official Resolution#	R20210428							
Meeting Date	04/27/2021							
Introduced Date	04/27/2021							
Adopted Date	04/27/2021							
Agenda Item	o-28							
CAF #	1-01-44-900-003-000							
Purchase Req. #								
Result	Adopted							
COMMISSIONER	PRES.	ABS.	MOVE	SEC	AYE	NAY	ABST.	RECU.
Lepore	✓				✓			
James	✓		✓		✓			
Akhter	✓			✓	✓			
Bartlett	✓				✓			
Best Jr.	✓				✓			
Duffy		✓						
Lazzara		✓						

PRES.= present ABS.= absent  
MOVE= moved SEC= seconded  
AYE= yes NAY= no ABST.= abstain  
RECU.= recuse

Introduced on: August 10, 2021  
Adopted on: August 10, 2021  
Official Resolution#: R20210746

Dated: April 28, 2021

**RESOLUTION AUTHORIZING THE PURCHASE OF VEHICLES FROM BEYER FORD, LLC FOR USE BY THE DIVISION OF ROADS, PURSUANT TO N.J.S.A. 40A:11-12, ET SEQ.**

**WHEREAS**, the County of Passaic (hereafter "County") is a government body incorporated pursuant to N.J.S.A. 40:18-1, et seq. and vested with all rights contained therein; and

**WHEREAS**, pursuant to N.J.S.A. 40:20-1 the Passaic Board of County Commissioners (hereafter "Board") is vested with decision making powers on behalf of the County; and

**WHEREAS**, pursuant to N.J.S.A. 40A:11-12, et seq., the County may, without advertising for bids, purchase goods or services under any contract or contracts for such goods or service entered into on behalf of the State by the Division of Purchase and Property in the Department of Treasury; and

**WHEREAS**, Beyer Ford, LLC submitted competitive pricing for Vehicles, Trucks, Class 4, Utility/Dump, with Snow Plow Option, Master Purchase Blanket Order No. 88214, to the State of New Jersey, Division of Purchase of Property in the Department of Treasury; and

**WHEREAS**, the Supervisor of Roads is seeking authorization for the purchase of two (2) 2022 Ford F-450 WD Reg Cab 145" WB 60" CA XL Base Model from Beyer Ford, LLC in an amount not to exceed one hundred sixty eight thousand five hundred fifty seven dollars (\$168,557.00); and

**WHEREAS**, funds are available in Account No. 1-01-44-900-003-000 or any other account that may be deemed appropriate by the Chief Financial Officer or his designee, and the availability of funds has been contingently certified by the Chief Financial Officer subject to sufficient funds being appropriated by the Board in the 2021 and/or subsequent years' County budget (s), which is attached to and made part of this Resolution; and

**WHEREAS**, this matter was discussed at the meeting on April 14, 2021 by the Public Works Committee and is being recommended to the Board for approval.

**NOW, THEREFORE, LET IT BE RESOLVED**, pursuant to N.J.S.A. 40A:11-12, et seq., that the Board of County Commissioners of the County of Passaic hereby authorizes the purchase of two (2) 2022 Ford F-450 WD Reg Cab 145" WB 60" CA XL Base Model from Beyer Ford, LLC in an amount not to exceed one hundred sixty-eight thousand five hundred fifty seven dollars (\$168,557.00).

**LET IT BE FURTHER RESOLVED**, that the Purchasing Agent and all other necessary officers and employees be and hereby are authorized and directed to take such further actions and sign such documents as are necessary to effectuate the purpose of this Resolution, including but not limited to issuance of an appropriate Purchase Order.

NDA

April 27, 2021



CERTIFICATION OF AVAILABLE FUNDS

THIS IS TO CERTIFY THAT FUNDS ARE AVAILABLE AS FOLLOWS:

AMOUNT: \$168,557.00

APPROPRIATION: 1-01-44-900-003-000

PURPOSE: Resolution authorizing the purchase of vehicles from Beyer Ford, LLC.



Richard Cahill, Director of Finance

DATED: April 27, 2021

RC:fr

COUNTY OF PASSAIC  
 ROADS DEPT, CO OF PASSAIC  
 (O) 973-881-4500  
 1310 ROUTE 23 NORTH  
 WAYNE, NJ 07470

REQUISITION	
NO.	RI-11981

SHIP TO	COUNTY OF PASSAIC ROAD DEPARTMENT 1310 ROUTE 23 NORTH WAYNE, NJ 07470
VENDOR	VENDOR #: 11508 BEYER OF MORRISTOWN, LLC T/A BEYER CHRYSLER DODGE JEEP 200 RIDGEDALE AVENUE MORRISTOWN, NJ 07960-4000

ORDER DATE: 04/08/21  
 DELIVERY DATE:  
 STATE CONTRACT: A88214  
 F.O.B. TERMS:

QTY/UNIT	DESCRIPTION	ACCOUNT NO.	UNIT PRICE	TOTAL COST
2.00	ROAD DEPARTMENT - WAYNE TWO (2) 2022 FORD F-450 4WD REG CAB 145" WB 60" CA XL BASE MODEL WITH FOLLOWING OPTIONS: LIMITED SLIP W/4 88 AXLE RATIO TIRES 225/70R19.5 BSW TRACTION POWER EQUIPMENT GROUP TRAILER TOW PACKAGE SNOW FLOW PRE PACKAGE DUAL 78 AH BATTERY 397 AMP ALTERNATORS GALION MODEL 133USD-9' STAINLESS STEEL DUMP BODY WITH SPREADER INSTALL IN BED OF TRUCKS  AS PER QUOTE DATED 3/18/2021  PER STATE CONTRACT NO. A88214  RESOLUTION NO.	1-01-44-900-003-000	84,278.5000	168,557.00
			TOTAL	168,557.00

Introduced on: April 27, 2021  
 Adopted on: April 27, 2021  
 Official Resolution#: R20210428  
 Introduced on: August 10, 2021  
 Adopted on: August 10, 2021  
 Official Resolution#: R20210746

REQUESTING DEPARTMENT \_\_\_\_\_ DATE \_\_\_\_\_

3/18/2021



## BEYER FORD

170 Ridgedale Ave.  
Morristown, NJ 07936

## Quote

To:	From:
Passaic Co	Jim Longobardi 31 Williams Parkway East Hanover, NJ 07936
	Phone/Fax (973) 319-7006 / (973) 884-2650

2022 FORD F-450 4WD REG CAB 145" WB 60" CA XL  
STATE OF NEW JERSEY  
CONTRACT # A88214

Engine: 7.3L 2V DEVCOT NA PFI V8 Gas  
Transmission: TorqShift 8-Speed Automatic  
4.88 Axle Ratio  
50-State Emissions System  
Transmission w/SelectShift Sequential Shift  
Manual Transfer Case  
Part-Time Four-Wheel Drive  
78-Amp/Hr 750CCA Maintenance-Free Battery  
HD 240 Amp Alternator  
Towing w/Harness and Trailer Sway Control  
GVWR: 16,500 lb Payload Package  
HD Shock Absorbers  
Front And Rear Anti-Roll Bars  
Firm Suspension  
Hydraulic Power-Assist Steering  
40 Gal. Fuel Tank  
Single Stainless Steel Exhaust  
Manual Locking Hubs  
Front Suspension w/Coil Springs  
Leaf Rear Suspension w/Leaf Springs  
4-Wheel Disc Brakes w/4-Wheel ABS  
Upfilter Switches  
Wheels: 19.5" Argent Painted Steel  
Tires: 225/70R19.5G BSW A/T  
Clearcoat Paint  
Black Front Bumper w/Black Rub Strip  
Black Fender Flares  
Black Side Windows Trim  
Black Door Handles  
Black Manual Side Mirrors w/Manual Folding  
Manual Extendable Trailer Style Mirrors  
Fixed Rear Window  
Light Tinted Glass  
Variable Intermittent Wipers  
Aluminum Panels  
Front Splash Guards  
Black Grille

4-Way Driver Seat -inc: Manual Recline  
4-Way Passenger Seat -inc: Manual Recline  
Manual Tilt/Telescoping Steering Column  
Gauges -inc: Speedometer, Odometer, Oil Pressure  
Temp, Engine Hour Meter, Trip Odometer & Trip Computer  
3 Person Seating Capacity  
Front Cupholder  
Manual Air Conditioning  
Illuminated Locking Glove Box  
Interior Trim -inc: Chrome Interior Accents  
Full Cloth Headliner  
Urethane Gear Shift Knob  
HD Vinyl 40/20/40 Split Bench Seat  
Day-Night Rearview Mirror  
Passenger Visor Vanity Mirror  
2 12V DC Power Outlets  
Front Map Lights  
Fade-To-Off Interior Lighting  
Full Vinyl/Rubber Floor Covering  
Underhood Lights  
Instrument Panel Bin and Covered Dashboard Storage  
Manual 1st Row Windows  
Systems Monitor  
Trip Computer  
Outside Temp Gauge  
Analog Display  
Manual Adjustable Front Head Restraints  
Air Filtration  
Driveline Traction Control  
Side Impact Beams  
Dual Stage Driver/Passenger Seat-Mounted Side Airbags  
Dual Stage Driver/Passenger Front Airbags  
Safety Canopy System Curtain 1st Row Airbags  
Outboard Front Lap And Shoulder Safety Belts  
Front License Plate Bracket  
Halogen Headlamps w/Delay-Off  
Cab Clearance Lights

Base Price \$ 32,914.00

\*\*\*Multiple vehicle purchases require payment per vehicle delivered.  
Individual payments required regardless of status of remaining vehicles.\*\*\*  
Adopted on: April 27, 2021  
Official Resolution#: R20210428

Introduced on: August 10, 2021  
Adopted on: August 10, 2021  
Official Resolution#: R20210746

COUNTY OF PASSAIC  
 ROADS DEPT, CO OF PASSAIC  
 (O) 973-881-4500  
 1310 ROUTE 23 NORTH  
 WAYNE, NJ 07470

REQUISITION	
NO.	R1-11981

SHIP TO	COUNTY OF PASSAIC ROAD DEPARTMENT 1310 ROUTE 23 NORTH WAYNE, NJ 07470
VENDOR	VENDOR #: 11508 BEYER OF MORRISTOWN, LLC T/A BEYER CHRYSLER DODGE JEEP 200 RIDGEDALE AVENUE MORRISTOWN, NJ 07960-4000

ORDER DATE: 04/08/21  
 DELIVERY DATE:  
 STATE CONTRACT: A88214  
 F.O.B. TERMS:

QTY/UNIT	DESCRIPTION	ACCOUNT NO.	UNIT PRICE	TOTAL COST
2.00	ROAD DEPARTMENT - WAYNE TWO (2) 2022 FORD F-450 4WD REG CAB 145" WB 60" CA XL BASE MODEL WITH FOLLOWING OPTIONS: LIMITED SLIP W/4 88 AXLE RATIO TIRES 225/70R19.5 BSW TRACTION POWER EQUIPMENT GROUP TRAILER TOW PACKAGE SNOW PLOW PRE PACKAGE DUAL 78 AH BATTERY 397 AMP ALTERNATORS GALION MODEL 133USD-9' STAINLESS STEEL DUMP BODY WITH SPREADER INSTALL IN BED OF TRUCKS  AS PER QUOTE DATED 3/18/2021  PER STATE CONTRACT NO. A88214  RESOLUTION NO.	1-01-44-900-003-000	84,278.5000	168,557.00
			TOTAL	168,557.00

Introduced on: April 27, 2021  
 Adopted on: April 27, 2021  
 Official Resolution#: R20210428  
  
 Introduced on: August 10, 2021  
 Adopted on: August 10, 2021  
 Official Resolution#: R20210746

REQUESTING DEPARTMENT \_\_\_\_\_ DATE \_\_\_\_\_

CERTIFICATION OF AVAILABLE FUNDS

THIS IS TO CERTIFY THAT FUNDS ARE AVAILABLE AS FOLLOWS:

AMOUNT: \$185,716.00

APPROPRIATION: 1-01-44-900-003-000

PURPOSE: Authorizing purchase of two 2022 Ford F-550 vehicles from Route 23 Automall for the Road Department.

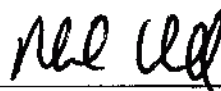

Richard Cahill, Director of Finance

DATED: August 10, 2021

# County of Passaic Board of County Commissioners

OFFICE OF COUNTY COMMISSIONERS

Director Pasquale "Pat" Lepore  
Deputy Director Bruce James  
Assad R. Akhter  
John W. Bartlett  
Theodore O. Best, Jr.  
Terry Duffy  
Cassandra "Sandi" Lazzara

401 Grand Street  
Paterson, New Jersey 07505  
Tel: 973-881-4402  
Fax: 973-742-3746

Anthony J. De Nova III  
*Administrator*  
Matthew P. Jordan, Esq.  
*County Counsel*  
Louis E. Imhof, III, RMC  
*Clerk Of The Board*



## Public Meeting (Board Meeting)

Date: Aug 10, 2021 - 5:30 PM

Location: County Administration Building  
Webex - 220  
401 Grand Street  
Paterson, NJ 07505

Agenda: RESOLUTION AUTHORIZING CHANGE ORDER NO. 2 TO JOHN O'HARA COMPANY INC. FOR THE LAMBERT CASTLE RESTORATION & REHABILITATION PROJECT, PURSUANT TO N.J.A.C. 5:30-11.3 ET SEQ., ALL AS NOTED IN THE RESOLUTION.

THIS RESOLUTION WAS REQUESTED BY:

REVIEWED BY:

Anthony J. De Nova III  
COUNTY ADMINISTRATOR

APPROVED AS TO FORM AND LEGALITY:

Matthew P. Jordan, Esq.  
COUNTY COUNSEL

Public Works

COMMITTEE NAME

<b>Official Resolution#</b>	<b>R20210747</b>							
Meeting Date	08/10/2021							
Introduced Date	08/10/2021							
Adopted Date	08/10/2021							
Agenda Item	I-31							
CAF #	C-04-55-162-001-901							
Purchase Req. #								
Result	Adopted							
<b>COMMISSIONER</b>	<b>PRES.</b>	<b>ABS.</b>	<b>MOVE</b>	<b>SEC</b>	<b>AYE</b>	<b>NAY</b>	<b>ABST.</b>	<b>RECU.</b>
Lepore	✓				✓			
James	✓		✓		✓			
Akhter	✓			✓	✓			
Bartlett	✓				✓			
Best Jr.	✓				✓			
Duffy	✓				✓			
Lazzara	✓				✓			

PRES.= present ABS.= absent  
MOVE= moved SEC= seconded  
AYE= yes NAY= no ABST.= abstain  
RECU.= recuse

Dated: August 11, 2021

**RESOLUTION AUTHORIZING CHANGE ORDER NO. 2 TO JOHN O'HARA COMPANY INC. FOR THE LAMBERT CASTLE RESTORATION & REHABILITATION PROJECT, PURSUANT TO N.J.A.C. 5:30-11.3 ET SEQ.**

**WHEREAS**, the County of Passaic (hereafter "County") is a body politic and corporate pursuant to N.J.S.A. 40:18-1 and vested with all rights contained therein; and

**WHEREAS**, pursuant to N.J.S.A. 40:20-1 the Board of County Commissioners of the County of Passaic (hereafter "Board") is vested with managing the property, finances, and affairs of the County; and

**WHEREAS**, pursuant to N.J.A.C. 5:30-11.3, et seq. the Board can authorize change orders pursuant to the conditions as set forth therein for work performed, services rendered, materials, supplies or equipment delivered or provided shall be authorized, permitted, or accepted except by the procedures established therein; and

**WHEREAS**, on December 8, 2020, the Board approved Resolution No. R20201118 awarding a contract to John O'Hara for the Lambert Castle Restoration & Rehabilitation Project (hereafter "Project") for an amount not to exceed six million seven hundred ninety-two thousand four hundred and fifteen dollars (\$6,792,415.00) pursuant to N.J.S.A. 40A:11-1, et seq.; and

**WHEREAS**, the Passaic County Director of Cultural and Historic Affairs is recommending that Change Order No. 2 be authorized for a net addition to the contract for the Project in the amount of three thousand seven hundred sixty-three dollars (\$3,763.00), due to installation of new plywood, wainscot, framing and gypsum board as a result of the removal of historic wall and material that has failed, which will result in an increase of the original contract to six million eight hundred thousand and six hundred sixty-three dollars (\$6,800,663.00); and

**WHEREAS**, funds are available in Account No. C-04-55-162-001-901 or any other account that may be deemed appropriate by the Chief Financial Officer or his designee, and the availability of funds has been contingently certified by the Chief Financial Officer subject to sufficient funds being appropriated by the Board in the 2021 and/or subsequent years' County budget(s), which is attached to and made part of this Resolution; and

**WHEREAS**, this matter was discussed on July 28, 2021, by the Public Works Committee and is being recommended to the Board for approval.

**NOW, THEREFORE, LET IT BE RESOLVED**, pursuant to N.J.A.C. 5:30-11.3, et seq., the Board of County Commissioners of the County of Passaic approves Change Order No. 2 in the amount of three thousand seven hundred sixty-three dollars (\$3,763.00), to John O'Hara Company, Inc. for the Lambert Castle Restoration & Rehabilitation Project, as recommended by the Director of Cultural and Historic Affairs.

**LET IT BE FURTHER RESOLVED**, that the Director of Cultural and Historic Affairs is authorized and directed to comply with the general requirements for change orders as set forth in N.J.A.C. 5:30-11.3, et seq.

**LET IT BE FURTHER RESOLVED**, that the Clerk of the Board, County Counsel, County Engineer, and Director of the Board of County Commissioners are authorized to execute and take any other action necessary to carry out the purpose of this Resolution.

NDA

August 10, 2021



MEMORANDUM

**Clarke Caton Hintz**  
Architecture  
Planning  
Landscape Architecture

**TO:** Kelly C. Ruffel, Director  
Department of Cultural & Historic Affairs, County of Passaic  
**FROM:** Michael Hanrahan, AIA  
**RE:** C-20-026 Lambert Castle – Restoration and Rehabilitation  
**DATE:** July 26, 2021

100 Barrack Street  
Trenton NJ 08608  
clarkecatonhintz.com  
Tel: 609 883 8383  
Fax: 609 883 4044

Clarke Caton Hintz conducted a thorough review of the proposed change orders:  
1. AWA 5 – Reframing of wall in room 117

The repair of the plaster wall uncovered, concealed and unforeseen deteriorated wood framing. The proposed cost of \$3,763.00 is a fair and reasonable price for the work.

Clarke Caton Hintz is available to clarify or answer any questions.

Sincerely,

Michael J. Hanrahan, AIA  
Principal

John Hatch, FAIA  
George Hibbs, AIA  
Brian Slauch, AICP  
Michael Sullivan, AICP  
Michael Hanrahan, AIA  
Mary Beth Loneragan, AICP



## JOHN O'HARA COMPANY, INC.

25 Kearney St., East Orange NJ 07019  
PHONE (973) 673-4676 FAX (973) 673-7141

### ADDITIONAL WORK AUTHORIZATION

<b>Project: Restoration &amp; Rehabilitation of Lambert Castle</b>	<b>Date:</b>	07/15/21
	<b>Job #</b>	PAS00010
<b>Paterson, NJ</b>	<b>CO #</b>	5
<b>Ref: Re-Framing of Wall Room 117</b>		

The following is a summary of additional costs required to complete work on the above referenced project which is above and beyond our current scope of work.

Removal of wall behind failed framing to have access. Removal of failed framing while temporary shoring. Installation of new plywood to pull bowed out wainscott to be flush. Installation of new wood framing and new gypsum board.

**All work will be done in accordance with:**

Attached estimate and attached SK drawing (Option A)

**The Following is a breakdown of costs for this work:**

Laborer - 1 Man Day		600
Carpenter Journeyman - 3 Man Days		2,352
Tapper - .5 Man Day		320
	<b>SUBTOTAL</b>	<b>3,272</b>
John O'Hara Company Overhead (10%) and Profit (5%)	15.0%	491
<b>TOTAL COST</b>		<b>3,763</b>

**The Following work is excluded:**

OT, Unforeseen aspects

Please indicate your approval of the above costs and your authorization to proceed by signing a copy of this correspondence and returning it to the sender.

Approved by:

Dated

--	--

Clarke Caton Hintz

Approved by:

Dated

--	--

County of Passaic



COUNTY OF PASSAIC  
 CO OF PASSAIC, DEY MANSION  
 (Q) 973-706-6640  
 199 TOTOWA ROAD  
 WAYNE, NJ 07470

**Purchase Order**

THIS NUMBER MUST APPEAR ON ALL INVOICES,  
 PACKING SLIPS, CORRESPONDENCE, ETC.

NO. 21-01727

ORDER DATE: 03/17/21

DELIVERY DATE:

STATE CONTRACT:

F.O.B. TERMS:

VENDOR ACCT NUM:

VENDOR PHONE #: (973)673-4676

VENDOR FAX #: (973)673-7141

REQUISITION #: R0-04988

**PAYMENT RECORD**

CHECK NO.

DATE PAID

Vendor #: 13725

JOHN O'HARA COMPANY, INC.  
 25 KEARNEY STREET  
 EAST ORANGE, NJ 07017

NOTICE: TAX EXEMPT - TAX ID: 22-6002466

QUANTITY	DESCRIPTION	ACCOUNTING	UNIT PRICE	TOTALS
1.00	Lambert Castle Restoration Lambert Castle Restoration & Rehabilitation Project C-20-026  Resolution No.R2020-1119 Resolution Date: December 8, 2020	C-04-55-162-001-901	6,792,415.0000	6,792,415.00
			TOTAL	6,792,415.00

<p><b>CLAIMANT'S CERTIFICATION &amp; DECLARATION</b></p> <p>I do solemnly declare and certify under penalties of the law that the within bill is correct in all its particulars; that the articles have been furnished or services rendered as stated therein; that no bonus has been given or received by any person or persons within the knowledge of this claimant in connection with the above claim; that the amount therein stated is justly due and owing; and that the amount charged is a reasonable one.</p> <p>_____                  VENDOR SIGN HERE</p> <p>Introduced on: August 10, 2021                  Adopted on: August 10, 2021                  Official Resolution#: R20210747</p> <p>TAX ID NO. OR SOCIAL SECURITY NO.</p>	<p><b>OFFICER'S CERTIFICATION</b></p> <p>I, having knowledge of the facts, certify that the materials and supplies have been received or the services rendered; said certification being based on signed delivery slips or other reasonable procedures.</p> <p>_____                  DEPT. HEAD      DATE</p> <p>VENDOR MUST SIGN CERTIFICATION STATEMENT ON THIS VOUCHER. MAIL VOUCHER &amp; ITEMIZED BILLS TO:                  COUNTY OF PASSAIC                  CO OF PASSAIC, DEY MANSION                  (Q) 973-706-6640                  199 TOTOWA ROAD                  WAYNE, NJ 07470</p>	<p><b>APPROVAL TO PURCHASE</b></p> <p>DO NOT ACCEPT THIS ORDER UNLESS IT IS SIGNED BELOW</p> <p><i>Sherry Avanzitakis</i>                  _____                  Purchasing Agent, QPA</p>
---	--	---

COUNTY OF PASSAIC

DEPARTMENT OF CULTURAL & HISTORIC AFFAIRS  
 DEY MANSION  
 199 TOTOWA ROAD  
 WAYNE, NJ 07470

CHANGE ORDER No. 2  
 PROJECT No. C-20-026  
 DATE: July 26, 2021

PROJECT TITLE: LAMBERT CASTLE RESTORATION & REHABILITATION

LOCATION: 3 VALLEY ROAD, PATERSON, NJ

DATE OF CONTRACT: January 4, 2021

OWNER: PASSAIC COUNTY BOARD OF COUNTY COMMISSIONERS

CONTRACTOR: JOHN O'HARA Company, Inc.

It is hereby mutually agreed that when this Change Order has been signed by the contracting parties the following described changes in work required by the contract shall be executed by the Contractor without changing the terms of the contract except as herein stipulated and agreed:

**1. DESCRIPTION AND VALUE OF CHANGE**

<u>ITEM</u>	<u>DESCRIPTION</u>	<u>QUANTITY</u>	<u>UNIT</u>	<u>PRICE</u>	<u>AMOUNT</u>
<b>Additions</b>					
1	The County requested additional site work to be done for Removal of wall behind failed framing to have access. Removal of failed framing while temporary shoring. Installation of new plywood to pull bowed out wainscott to be flush. Installation of new wood framing and new gypsum board.	1	EA	\$3,763	\$ 3,763.00
<b>Total Extras</b>					<b>\$ 3,763.00</b>
<b>Total Supplementals</b>					<b>\$ -</b>
<b>Total Adds</b>					<b>\$ 3,763.00</b>

1. DESCRIPTION AND VALUE OF CHANGE (Con't)

ADD TO THE AMOUNT OF CONTRACT.....  
 ORIGINAL DATE FOR COMPLETION..... January 21, 2022  
 ADD TO OR DEDUCT FROM - THE PRESENT CONTRACT TIME..... 0 Calendar Days  
 NEW DATE FOR COMPLETION IS..... January 21, 2022

**2. REASON FOR CHANGE**

The County requested additional site work to be done for Removal of wall behind failed framing to have access. Removal of failed framing while temporary shoring. Installation of new plywood to pull bowed out wainscott to be flush. Installation of new wood framing and new gypsum board.

COUNTY OF PASSAIC

DEPARTMENT OF CULTURAL & HISTORIC AFFAIRS  
 DEY MANSION  
 199 TOTOWA ROAD  
 WAYNE, NJ 07470

CHANGE ORDER No. 2  
 PROJECT No. C-20-026  
 DATE: July 26, 2021

PROJECT TITLE: LAMBERT CASTLE RESTORATION & REHABILITATION  
 LOCATION: 3 VALLEY ROAD, PATERSON, NJ  
 DATE OF CONTRACT: January 4, 2021  
 OWNER: PASSAIC COUNTY BOARD OF COUNTY COMMISSIONERS  
 CONTRACTOR: JOHN O'HARA Company, Inc.

3. STATEMENT OF CONTRACT AMOUNT

ORIGINAL CONTRACT AMOUNT.....	\$ 6,792,415.00
PREVIOUS ADDITIONS.....	\$ 4,485.00
TOTAL.....	\$ 6,796,900.00
PREVIOUS DEDUCTIONS.....	\$ -
NET PRIOR TO THIS CHANGE.....	\$ 6,796,900.00
AMOUNT OF THIS CHANGE (Add).....	\$ 3,763.00
CONTRACT AMOUNT TO DATE.....	\$ 6,800,663.00

CONTRACTOR'S PROPOSAL FOR THE ABOVE DESCRIBED CHANGES:

I/We hereby agree to the modifications of the contract as described above and agree to furnish all materials, equipment, and labor to perform all work in connection therewith in accordance with the requirements for similar work in the existing contract except as otherwise stipulated therein for the above consideration.

I/We hereby release the County of Passaic, the Board of County Commissioners, their agents, officers and employees from any claims and liability of whatsoever nature for anything done or furnished or in any manner growing out of the performance of the work.

CONTRACTOR John O' Hara Company, Inc.

SIGNATURE \_\_\_\_\_ DATE \_\_\_\_\_

You are hereby authorized to supply all labor, equipment, and material for the above change as provided under the terms of your contract; all to be in accordance with the plans and specifications and modifications thereof. Your Contract is increased or decreased by the amount given above which is agreed upon.

Reviewed By and Prepared By: \_\_\_\_\_ Date \_\_\_\_\_  
 (Director Dept. Cultural & Historic Affairs)

Reviewed By and Recommended for Processing By: \_\_\_\_\_ Date \_\_\_\_\_  
 (County Architect)

Recommend for Approval By: \_\_\_\_\_ Date \_\_\_\_\_  
 (County Engineer)

ACCEPTED BY: BOARD OF COUNTY COMMISSIONERS OF PASSAIC COUNTY

SIGNATURE \_\_\_\_\_ DATE: \_\_\_\_\_  
 Pasquaie "Pat" Lepore - Director

CERTIFICATION OF AVAILABLE FUNDS

THIS IS TO CERTIFY THAT FUNDS ARE AVAILABLE AS FOLLOWS:

AMOUNT: \$3,763.00

APPROPRIATION: C-04-55-162-001-901

PURPOSE: Authorizing Change Order No. 2 to John O'Hara Company Inc. for the Lambert Castle Restoration & Rehabilitation Project.



Richard Cahill, Director of Finance

DATED: August 10, 2021

# County of Passaic Board of County Commissioners

OFFICE OF COUNTY COMMISSIONERS

Director Pasquale "Pat" Lepore  
Deputy Director Bruce James  
Assad R. Akhter  
John W. Bartlett  
Theodore O. Best, Jr.  
Terry Duffy  
Cassandra "Sandi" Lazzara

401 Grand Street  
Paterson, New Jersey 07505

Tel: 973-881-4402  
Fax: 973-742-3746

Anthony J. De Nova III  
Administrator

Matthew P. Jordan, Esq.  
County Counsel

Louis E. Imhof, III, RMC  
Clerk Of The Board



## Public Meeting (Board Meeting)

Date: Aug 10, 2021 - 5:30 PM

Location: County Administration Building  
Webex - 220  
401 Grand Street  
Paterson, NJ 07505

Agenda: RESOLUTION AUTHORIZING PURCHASE OF SEVEN YAMAHA GOLF UTILITY CARS FROM GOLF CAR SPECIALTIES CATALOG PERCENTAGE DISCOUNT PRICING PURSUANT TO N.J.S.A 40A: 11-1, ET SEQ., ALL AS NOTED IN THE RESOLUTION.

THIS RESOLUTION WAS REQUESTED BY:

REVIEWED BY:

Anthony J. De Nova III  
COUNTY ADMINISTRATOR

APPROVED AS TO FORM AND LEGALITY:

Matthew P. Jordan, Esq.  
COUNTY COUNSEL

Public Works

COMMITTEE NAME

<b>Official Resolution#</b>		<b>R20210748</b>						
Meeting Date		08/10/2021						
Introduced Date		08/10/2021						
Adopted Date		08/10/2021						
Agenda Item		I-32						
CAF #		1-01-44-900-003-000						
Purchase Req. #								
Result		Adopted						
<b>COMMISSIONER</b>	<b>PRES.</b>	<b>ABS.</b>	<b>MOVE</b>	<b>SEC</b>	<b>AYE</b>	<b>NAY</b>	<b>ABST.</b>	<b>RECU.</b>
Lepore	✓				✓			
James	✓		✓		✓			
Akhter	✓			✓	✓			
Bartlett	✓				✓			
Best Jr.	✓				✓			
Duffy	✓				✓			
Lazzara	✓				✓			

PRES.= present ABS.= absent  
MOVE= moved SEC= seconded  
AYE= yes NAY= no ABST.= abstain  
RECU.= recuse

Dated: August 11, 2021

**RESOLUTION AUTHORIZING PURCHASE OF SEVEN YAMAHA GOLF UTILITY CARS  
FROM GOLF CAR SPECIALTIES CATALOG PERCENTAGE DISCOUNT PRICING  
PURSUANT TO N.J.S.A. 40A: 11-1, ET SEQ.**

**WHEREAS**, the County of Passaic (hereafter “County”) is a government body incorporated pursuant to N.J.S.A. 40:18-1, et seq. and vested with all rights contained therein; and

**WHEREAS**, pursuant to N.J.S.A. 40:20-1, the Board of County Commissioners for the County of Passaic (hereafter “Board”) is vested with decision making powers on behalf of the County; and

**WHEREAS**, pursuant to N.J.S.A. 40A:11-4, et seq., every contract awarded by the County, for the provision or performance of any goods or services, the cost of which in the aggregate exceeds the bid threshold [40A:11-3], shall be awarded only by resolution of the Board to the lowest responsible bidder after public advertising for bids and bidding thereof; and

**WHEREAS**, on March 1, 2021 the Purchasing Agent issued Catalog Percentage Discount Pricing – Parts for Yamaha Golf Carts, Bid No. SB-21-029 (hereafter “SB-21-029”) seeking sealed proposals from qualified bidders for catalog discount pricing for parts to service Yamaha Golf Cars at the Preakness Valley Golf Course, to be used on an as-needed basis; and

**WHEREAS**, on April 27, 2021, the Board passed Resolution R20210379 authorizing an award of contract to Golf Car Specialties for a contract term beginning April 14, 2021 and expiring April 14, 2022, with a one (1) year option to renew to purchase goods and services on an as-need basis; and

**WHEREAS**, the Director of the Department and Parks and Recreation is requesting authorization to purchase seven (7) Yamaha Golf Utility Cars (UMAX Rally 1 EFI Gas Utility Vehicles) from Golf Car Specialties for an amount not to exceed fifty seven thousand two hundred forty-six dollars (\$57,246.00) to be use by the Parks and Recreation Department for maintenance of the Preakness Valley Golf Course; and

**WHEREAS**, funds are available in Account No. 1-01-44-900-003-000 or any other account that may be deemed appropriate by the Chief Financial Officer or his designee, and the availability of funds has been contingently certified by the Chief Financial Officer subject to sufficient funds being appropriated by the Board in the 2021 and/or subsequent years’ County budget (s), which is attached to and made part of this Resolution; and

**WHEREAS**, this matter was discussed at the July 28, 2021, Public Works Committee, and is being recommended to the Board for approval.

**NOW, THEREFORE, LET IT BE RESOLVED**, pursuant to N.J.S.A. 40A:11-1, et seq. the Board of County Commissioners of the County of Passaic authorizes the purchase of seven (7) Yamaha Golf Utility Cars (UMAX Rally 1 EFI Gas Utility Vehicles) for an amount not to exceed fifty-seven thousand two hundred forty-six dollars (\$57,246.00) to be used by the Parks and Recreation Department for the maintenance of Preakness Valley Golf Course.

**LET IT BE FURTHER RESOLVED**, that the Clerk of the Board, County Counsel, and Director of the Board of County Commissioners, and Purchasing Agent are authorized to execute an agreement with Golf Car Specialties and take any other steps necessary to carry out the purpose of this resolution.

NDA

August 10, 2021

COUNTY OF PASSAIC  
 CO OF PASSAIC, PARKS DEPT  
 (Q) 973-881-4832  
 1310 ROUTE 23 NORTH  
 WAYNE, NJ 07470

REQUISITION	
NO.	R1-13783

SHIP TO	COUNTY OF PASSAIC PARKS - CLUBHOUSE 209 TOTOWA AVENUE WAYNE, NJ 07470
VENDOR	VENDOR #: 06203 GOLF CAR SPECIALTIES 3363 W RIDGE PIKE POTTSTOWN, PA 19464

ORDER DATE: 07/22/21  
 DELIVERY DATE:  
 STATE CONTRACT:  
 F.O.B. TERMS:

QTY/UNIT	DESCRIPTION	ACCOUNT NO.	UNIT PRICE	TOTAL COST
7.00	Yamaha Golf Utility Cars UMAX Rally 1 EFI Gas Utility Vehicles SB-21-029 Pending Resolution 8/10/21	1-01-44-900-003-000	8,178.0000	57,246.00
			TOTAL	57,246.00

Introduced on: August 10, 2021  
 Adopted on: August 10, 2021  
 Official Resolution#: R20210748

\_\_\_\_\_  
 REQUESTING DEPARTMENT DATE



CERTIFICATION OF AVAILABLE FUNDS

THIS IS TO CERTIFY THAT FUNDS ARE AVAILABLE AS FOLLOWS:

AMOUNT: \$57,246.00

APPROPRIATION: 1-01-44-900-003-000

PURPOSE: Authorizing purchase of seven Yamaha Golf Utility Cars from Golf Car Specialties for the maintenance of Preakness Valley Golf Course.



Richard Cahill, Director of Finance

DATED: August 10, 2021

# County of Passaic Board of County Commissioners

OFFICE OF COUNTY COMMISSIONERS

Director Pasquale "Pat" Lepore  
Deputy Director Bruce James  
Assad R. Akhter  
John W. Bartlett  
Theodore O. Best, Jr.  
Terry Duffy  
Cassandra "Sandi" Lazzara

401 Grand Street  
Paterson, New Jersey 07505  
Tel: 973-881-4402  
Fax: 973-742-3746

Anthony J. De Nova III  
*Administrator*  
Matthew P. Jordan, Esq.  
*County Counsel*  
Louis E. Imhof, III, RMC  
*Clerk Of The Board*



## Public Meeting (Board Meeting)

Date: Aug 10, 2021 - 5:30 PM

Location: County Administration Building  
Webex - 220  
401 Grand Street  
Paterson, NJ 07505

Agenda: RESOLUTION AUTHORIZING RIGHT OF WAY ENCROACHMENT PERMIT FOR INSTALLATION OF DIGITAL FIBER OPTIC COMMUNICATION CABINETS FOR ALTICE / CABLEVISION AT VARIOUS LOCATIONS WITHIN THE TOWNSHIP OF WAYNE, NEW JERSEY PURSUANT TO N.J.S.A.40:20-1, ALL AS NOTED IN THE RESOLUTION.

THIS RESOLUTION WAS REQUESTED BY:

REVIEWED BY:

Anthony J. De Nova III  
COUNTY ADMINISTRATOR

APPROVED AS TO FORM AND LEGALITY:

Matthew P. Jordan, Esq.  
COUNTY COUNSEL

Public Works  
COMMITTEE NAME

<b>Official Resolution#</b>	<b>R20210749</b>							
Meeting Date	08/10/2021							
Introduced Date	08/10/2021							
Adopted Date	08/10/2021							
Agenda Item	I-33							
CAF #								
Purchase Req. #								
Result	Adopted							
<b>COMMISSIONER</b>	<b>PRES.</b>	<b>ABS.</b>	<b>MOVE</b>	<b>SEC</b>	<b>AYE</b>	<b>NAY</b>	<b>ABST.</b>	<b>RECU.</b>
Lepore	✓				✓			
James	✓		✓		✓			
Akhter	✓			✓	✓			
Bartlett	✓				✓			
Best Jr.	✓				✓			
Duffy	✓				✓			
Lazzara	✓				✓			

PRES.= present ABS.= absent  
 MOVE= moved SEC= seconded  
 AYE= yes NAY= no ABST.= abstain  
 RECU.= recuse

Dated: August 11, 2021

**RESOLUTION AUTHORIZING RIGHT OF WAY ENCROACHMENT PERMIT FOR INSTALLATION OF DIGITAL FIBER OPTIC COMMUNICATION CABINETS FOR ALTICE / CABLEVISION AT VARIOUS LOCATIONS WITHIN THE TOWNSHIP OF WAYNE, NEW JERSEY PURSUANT TO N.J.S.A.40:20-1**

**WHEREAS**, the County of Passaic (hereafter “County”) is a body politic and corporate pursuant to N.J.S.A. 40:18-1 and vested with all rights contained therein; and

**WHEREAS**, pursuant to N.J.S.A. 40:20-1 the Board of County Commissioners of the County of Passaic (hereafter “Board”) is vested with managing the property, finances, and affairs of the County; and

**WHEREAS**, the County of Passaic has a policy which prohibits the placement of encroachments on rights-of-way of the County of Passaic; and

**WHEREAS**, the Altice/Cablevision submitted Right-of-way encroachment permit applications for the following locations 1299 Ratzer Road, across from 1083 Alps Road, 914 Black Oak Ridge Road, 170 Colfax Avenue and next to 611 Ratzer Road as required and are attached hereto and made a part hereof; and

**WHEREAS**, the encroachment consists of installation of fiber optic digital communication cabinets at various locations in the Township of Wayne within the County Right-of-Way which shall be reviewed by the Applicant’s licensed engineer or architect; and

**WHEREAS**, Altice/Cablevision (hereafter “Property Owner”), shall hold the County of Passaic and its agents and employees harmless for any damages incurred as a result of this encroachment. All equipment shall be located outside of the minimum required clear zone for the adjacent roadway. Upon proper notice from the County of Passaic, the Property Owner is to remove the encroachment at its expense should the County of Passaic require the use of the right-of-way for any other reason as may be required by the County of Passaic in the future; and

**WHEREAS**, should the Property Owner modify or abandon the need for this encroachment, the part containing the encroachment of the structures shall be removed and, thus, this encroachment permission within the County right-of-way shall cease to exist; and

**WHEREAS**, this matter was discussed at the July 28, 2021, meeting of the Public Works Committee and is being recommended to the Board for approval.

**NOW, THEREFORE, LET IT BE RESOLVED**, pursuant to N.J.S.A. 40:20-1, that the Board of County Commissioners of the County of Passaic authorizes the encroachment permit for property located at 1299 Ratzer Road, across from 1083 Alps Road, 914 Black Oak Ridge Road, 170 Colfax Avenue and next to 611 Ratzer Road, subject to the above-stated terms and conditions.

**BE IT FURTHER RESOLVED**, that the aforesaid encroachment permit is not to be considered a change of policy by the County of Passaic and future requests for encroachment permit shall be considered on a case-to-case basis.

**BE IT FURTHER RESOLVED**, the Director, Clerk of the Board and County Counsel are hereby authorized to execute an Encroachment Agreement on behalf of Passaic County.

NDA

August 10, 2021



## County of Passaic

Administration Building

401 Grand Street • Paterson, New Jersey 07505-2023

OFFICE OF THE COUNTY ENGINEER  
ROOM 524

Jonathan C. Pera, P.E.  
County Engineer

TEL: (973) 881-4456  
FAX: (973) 742-3936  
TDD: (973) 279-9786

July 26, 2021

Passaic County Board of Commissioners  
401 Grand Street  
Paterson, NJ 07505

RE: Encroachment Permit Applications  
Applicant: Altice/Cablevision  
Address: Various Locations  
Municipality: Township of Wayne

Dear Members of the Board:

This office has received and reviewed Right-of-Way Encroachment Permit Applications for the installation of digital communication cabinets at the following locations within the Wayne Township:

- 1299 Ratzer Road
- Across from 1083 Alps Road
- 914 Black Oak Ridge Road
- 170 Colfax Avenue
- Next to 611 Ratzer Road

The encroachments pose no adverse effect on vehicular or pedestrian traffic at the locations as designed.

The conditions of the permit shall include:

1. All equipment shall be located outside of the minimum required clear zone for the adjacent roadway.
2. The applicant/owner agrees to hold the County of Passaic and its agents and employees harmless for any damages incurred as a result of the granted encroachment.
3. Upon proper notice from the County of Passaic, the owner agrees to remove all or any of the encroachments at his expense for any reason as may be required by the County of Passaic in the future.
4. Should the owner modify or abandon the need for the encroachments, the portion(s) containing the encroachment of this structure or other feature shall be removed by the owner at his expense; and thus said encroachment permission within the County's right-of-way shall cease to exist.

Our office recommends the Encroachment Permits be approved and issued to the applicant, with the conditions noted above.

Very truly yours,

  
Nordan Murphy, P.E.  
Assistant County Engineer

Introduced on: August 10, 2021  
Adopted on: August 10, 2021  
Official Resolution#: R20210749

Attachment

cc: Jonathan Pera, PE, County Engineer  
Matthew Jordan, Esq., County Counsel  
Anthony DeNova, County Administrator

Introduced on: August 10, 2021  
Adopted on: August 10, 2021  
Official Resolution#: R20210749



**County of Passaic**  
**Administration Building**  
 401 Grand Street • Paterson, New Jersey 07505-2023

OFFICE OF THE COUNTY ENGINEER  
 Room 524  
 TEL: (973) 881-4456  
 FAX: (973) 742-3936  
 TDD: (973) 279-9786  
 roadpermits@passaiccountynj.org

**APPLICATION FOR RIGHT-OF-WAY ENCROACHMENT PERMIT**

SCOTT DOUGHMAN JUNE 21, 2021  
 Name of Applicant Date

Owner \_\_\_\_\_ Partner \_\_\_\_\_ Authorized Corporate Official X

ALTICE/CABLEVISION  
 Name of Company (If applicable)

Partnership \_\_\_\_\_ Corporation X

ROLT 56 - 1299 RATER RD.  
 Street Address of Encroachment

WAYNE, NJ 2117 117  
 Municipality Block(s) Lots(s)

Type of Encroachment (check all that apply): New X Existing \_\_\_\_\_

Canopy(s) \_\_\_\_\_ Sign(s) \_\_\_\_\_

Building Structure (1<sup>st</sup> Floor) \_\_\_\_\_ Building Structure (2<sup>nd</sup> Floor or higher) \_\_\_\_\_

Callar Door(s) \_\_\_\_\_ Roof Overhang \_\_\_\_\_

Window Overhang \_\_\_\_\_ Door Opens into County Right-of-way \_\_\_\_\_

Fence \_\_\_\_\_ Retaining Wall \_\_\_\_\_

Other X Describe: INSTALL FIBER OPTIC CABINET W UTILITY R.O.W.

40 POTASH RD. OAKLAND NJ 07436  
 Address of Applicant City State Zip

646-772-0284 (SHAUN) S MAXWELL @ CABLEVISION.COM  
 Telephone Number Email

The following must accompany the application:

- Four (4) copies of the property survey/site plan showing and describing in detail the encroachment with dimensions and outside boundaries; and the County of Passaic Right-of-Way Line.
- Photographs clearly showing the existing encroachment. The center of the picture should be oriented along the Right-of-Way line. Note: If any excavation is required in the road or right of way, in addition to this permit please submit a completed Highway Opening and Use Permit Application (FORM: ROAD-HWYOPENPERMITAPP).

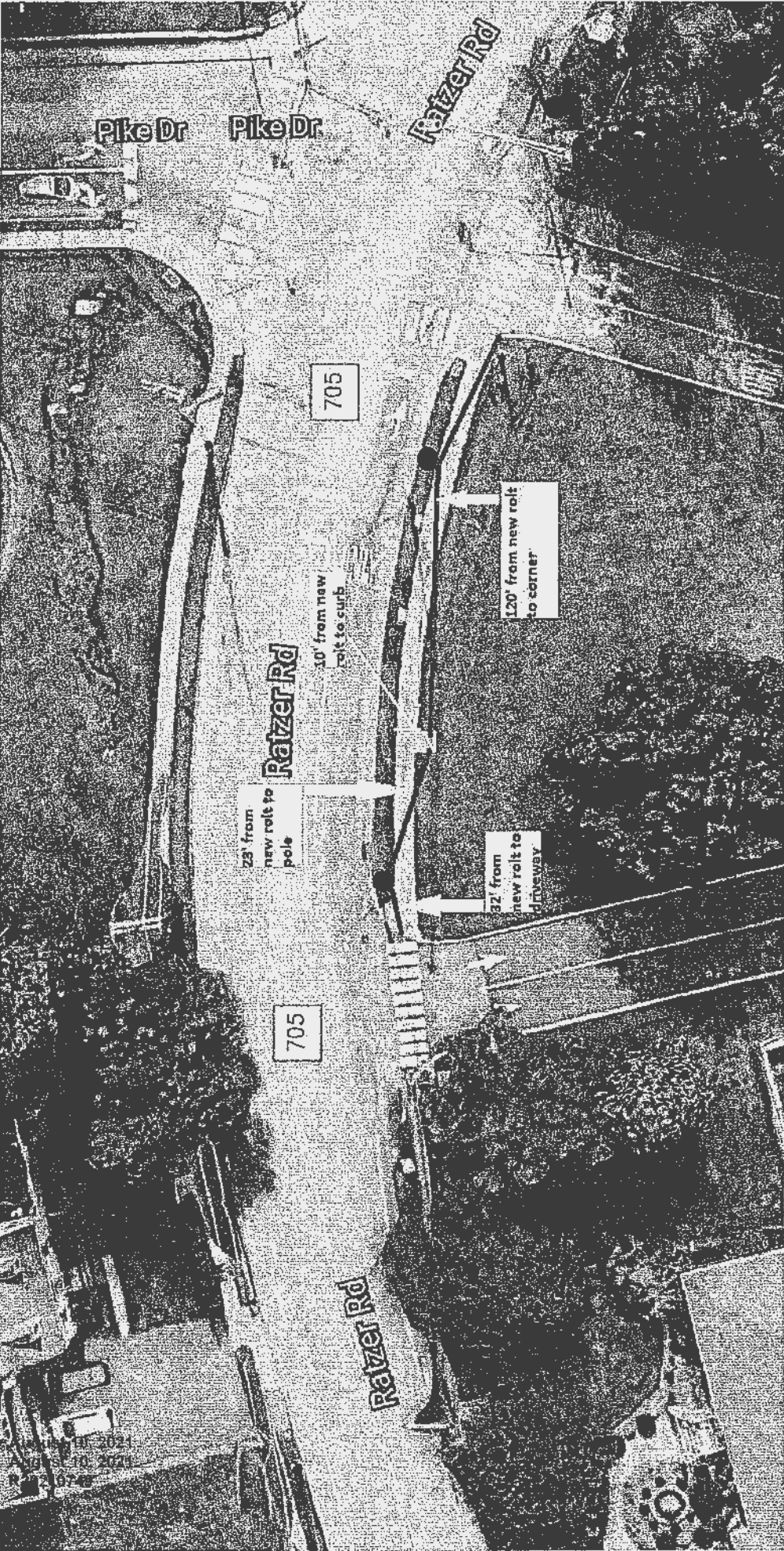

Introduced on: 10/10/2021  
 Adopted on: 10/10/2021  
 Official Resolution#: R 2021-157-42



County of Passaic  
Administration Building  
401 Grand Street • Paterson, New Jersey 07505-2023

OFFICE OF THE COUNTY ENGINEER  
Room 524  
TEL: (973) 881-4456  
FAX: (973) 742-3936  
TDD: (973) 279-9786  
[roadpermits@passaiccountynj.org](mailto:roadpermits@passaiccountynj.org)

APPLICATION FOR RIGHT-OF-WAY ENCROACHMENT PERMIT

SCOTT DOUGHMAN JUNE 21, 2021  
Name of Applicant Date

Owner \_\_\_\_\_ Partner \_\_\_\_\_ Authorized Corporate Official X

ALTICE/CABLEVISION  
Name of Company (if applicable)

Partnership \_\_\_\_\_ Corporation X

ROLT 57 - ACROSS FROM 1083 ALPS RD.  
Street Address of Encroachment

WAYNE NJ 2205 69  
Municipality Block(s) Lots(s)

Type of Encroachment (check all that apply): New X Existing \_\_\_\_\_

Canopy(s) \_\_\_\_\_ Sign(s) \_\_\_\_\_

Building Structure (1<sup>st</sup> Floor) \_\_\_\_\_ Building Structure (2<sup>nd</sup> Floor or higher) \_\_\_\_\_

Cellar Door(s) \_\_\_\_\_ Roof Overhang \_\_\_\_\_

Window Overhang \_\_\_\_\_ Door Opens into County Right-of-way \_\_\_\_\_

Fence \_\_\_\_\_ Retaining Wall \_\_\_\_\_

Other X Describe: INSTALL FIBER OPTIC CABINET IN UTILITY R.O.W

40 POTASH RD. OAKLAND NJ 07436  
Address of Applicant City State Zip

646-772-0284 (SHAUN) 5 MAXWELL @ CABLEVISION.COM  
Telephone Number Email

The following must accompany the application:

- Four (4) copies of the property survey/site plan showing and describing in detail the encroachment with dimensions and outside boundaries; and the County of Passaic Right-of-Way Line.
- Photographs clearly showing the existing encroachment. The center of the picture should be oriented along the Right-of-Way line. Note: If any excavation is required in the road or right of way, in addition to this permit please submit a completed Highway Opening and Use Permit Application (FORM: ROAD-HWYOPENPERMITAPP).



Gate of Wayne

80' from new  
roft to  
driveway

39' from  
new roft  
to pole  
at the  
corner

5' from new  
roft to curb

Alps Rd

Summit Dr

Introduced on:  
Adopted on:  
Official Resol



**County of Passaic**  
**Administration Building**  
 401 Grand Street • Paterson, New Jersey 07505-2023

OFFICE OF THE COUNTY ENGINEER  
 Room 524  
 TEL: (973) 881-4456  
 FAX: (973) 742-3936  
 TDD: (973) 279-9786  
 roadpermits@passaiccountynj.org

**APPLICATION FOR RIGHT-OF-WAY ENCROACHMENT PERMIT**

SCOTT DOUGLASS JUNE 21, 2021  
 Name of Applicant Date

Owner  Partner  Authorized Corporate Official

ALTICE/CABLEVISION  
 Name of Company (if applicable)

Partnership  Corporation

ROLL 60 - 914 BLACK OAK RINGE RD.  
 Street Address of Encroachment

WAYNE 3305 93  
 Municipality Block(s) Lots(s)

Type of Encroachment (check all that apply): New  Existing

Canopy(s)  Sign(s)

Building Structure (1<sup>st</sup> Floor)  Building Structure (2<sup>nd</sup> Floor or higher)

Cellar Door(s)  Roof Overhang

Window Overhang  Door Opens into County Right-of-way

Fence  Retaining Wall

Other  Describe: INSTALL FIBER OPTIC CABINET IN UTILITY R.O.W

40 POTASH RD. OAKLAND NJ 07436  
 Address of Applicant City State Zip

646-772-0284 (SHAUN) S MAXWELL @ CABLEVISION.COM  
 Telephone Number Email

The following must accompany the application:

- Four (4) copies of the property survey/site plan showing and describing in detail the encroachment with dimensions and outside boundaries; and the County of Passaic Right-of-Way Line.
- Photographs clearly showing the existing encroachment. The center of the picture should be oriented along the Right-of-Way line. Note: If any excavation is required in the road or right of way, in addition to this permit please submit a completed Highway Opening and Use Permit Application (FORM: ROAD-HWYOPENPERMITAPP).

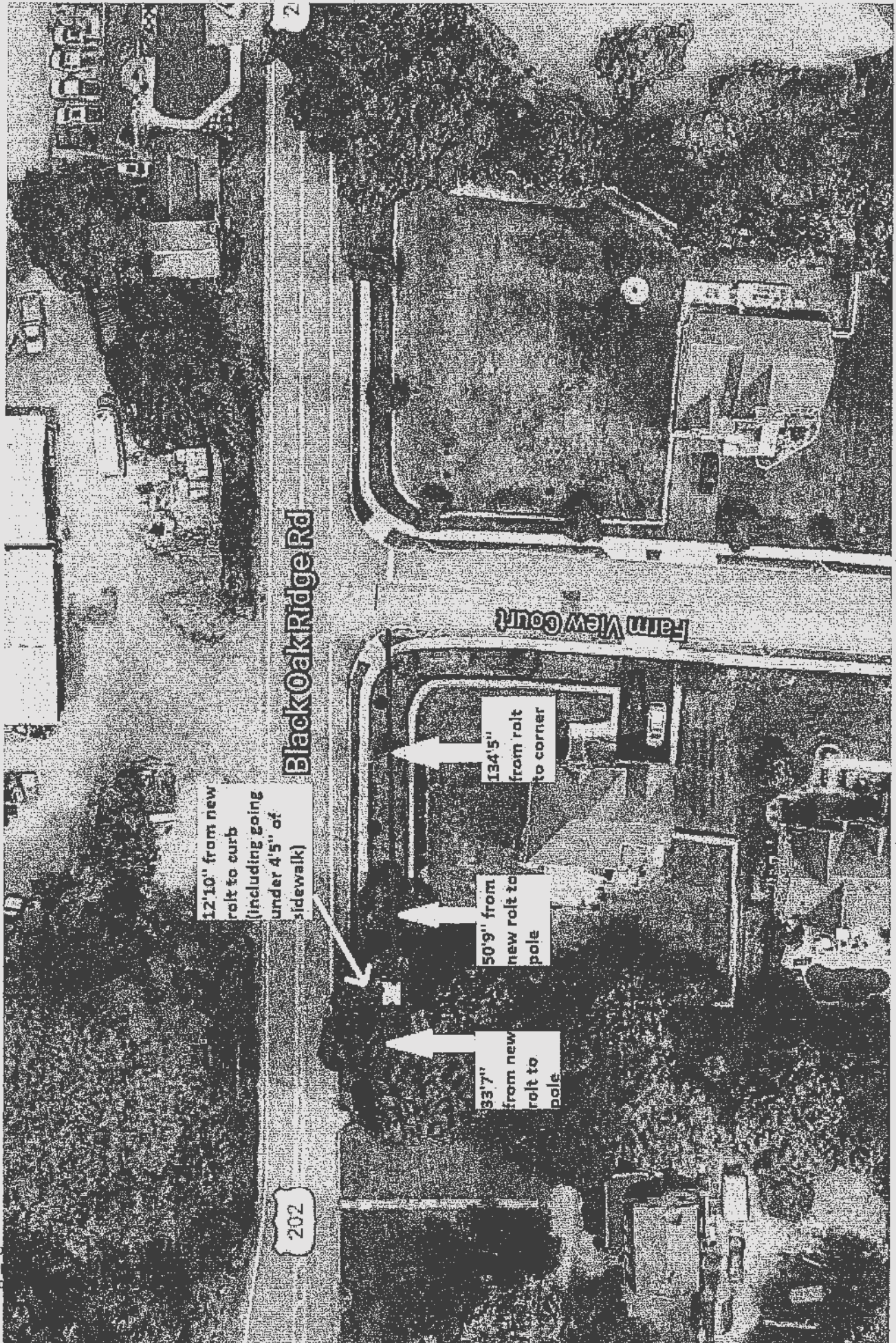

12'10" from new rolt to curb (including going under 4'5" of sidewalk)

50'9" from new rolt to pole

33'7" from new rolt to pole

134'5" from rolt to corner

Blackoak Ridge Rd

Farm View Court

202



**County of Passaic  
Administration Building  
401 Grand Street • Paterson, New Jersey 07505-2023**

**OFFICE OF THE COUNTY ENGINEER**  
Room 524  
TEL: (973) 881-4456  
FAX: (973) 742-3936  
TDD: (973) 279-9786  
[roadpermits@passaiccountynj.org](mailto:roadpermits@passaiccountynj.org)

**APPLICATION FOR RIGHT-OF-WAY ENCROACHMENT PERMIT**

SCOTT DOUGHERMAN JUNE 21, 2021  
Name of Applicant Date

Owner \_\_\_\_\_ Partner \_\_\_\_\_ Authorized Corporate Official X

ALTICE/CABLEVISION  
Name of Company (if applicable)

Partnership \_\_\_\_\_ Corporation X

ROUTE 61 - 170 COLFAX AVE.  
Street Address of Encroachment

WAYNE 3611 66  
Municipality Block(s) Lots(s)

Type of Encroachment (check all that apply): New X Existing \_\_\_\_\_

Canopy(s) \_\_\_\_\_ Sign(s) \_\_\_\_\_

Building Structure (1<sup>st</sup> Floor) \_\_\_\_\_ Building Structure (2<sup>nd</sup> Floor or higher) \_\_\_\_\_

Cellar Door(s) \_\_\_\_\_ Roof Overhang \_\_\_\_\_

Window Overhang \_\_\_\_\_ Door Opens into County Right-of-way \_\_\_\_\_

Fence \_\_\_\_\_ Retaining Wall \_\_\_\_\_

Other X Describe: INSTALL FIBER OPTIC CABINET IN UTILITY R.O.W.

40 POTASH RD. OAKLAND NJ 07436  
Address of Applicant City State Zip  
646-772-0284 (SHAUN) S MAXWELL @ CABLEVISION.COM  
Telephone Number Email

The following must accompany the application:

- Four (4) copies of the property survey/site plan showing and describing in detail the encroachment with dimensions and outside boundaries; and the County of Passaic Right-of-Way Line.
- Photographs clearly showing the existing encroachment. The center of the picture should be oriented along the Right-of-Way line. Note: If any excavation is required in the road or right of way, in addition to this permit please submit a completed Highway Opening and Use Permit Application (FORM: ROAD-HWYOPENPERMITAPP).

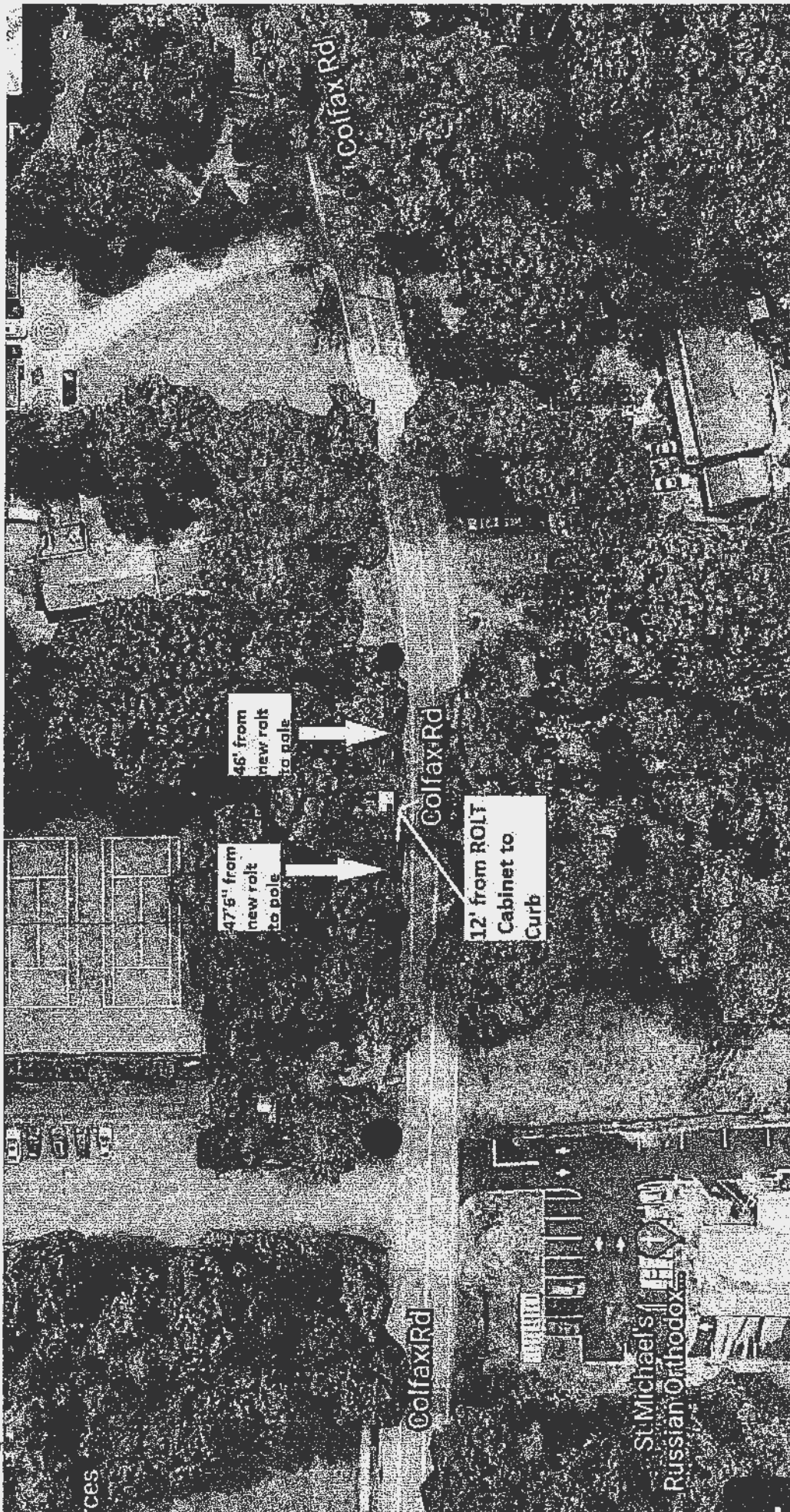

Introduced on:  
Adopted on:  
Official Resolution



**County of Passaic  
Administration Building  
401 Grand Street • Paterson, New Jersey 07505-2023**

OFFICE OF THE COUNTY ENGINEER  
Room 524  
TEL: (973) 881-4456  
FAX: (973) 742-3936  
TDD: (973) 279-9786  
[roadpermits@passaiccountynj.org](mailto:roadpermits@passaiccountynj.org)

**APPLICATION FOR RIGHT-OF-WAY ENCROACHMENT PERMIT**

SCOTT DOUBHMAN JUNE 21, 2021  
Name of Applicant Date

Owner \_\_\_\_\_ Partner \_\_\_\_\_ Authorized Corporate Official X

ALTICE/CABLEVISION  
Name of Company (if applicable)

Partnership \_\_\_\_\_ Corporation X

ROLT 77 - NEXT TO 611 RATER RD.  
Street Address of Encroachment

WAYNE 2329 16  
Municipality Block(s) Lots(s)

Type of Encroachment (check all that apply): New X Existing \_\_\_\_\_

Canopy(s) \_\_\_\_\_ Sign(s) \_\_\_\_\_

Building Structure (1<sup>st</sup> Floor) \_\_\_\_\_ Building Structure (2<sup>nd</sup> Floor or higher) \_\_\_\_\_

Cellar Door(s) \_\_\_\_\_ Roof Overhang \_\_\_\_\_

Window Overhang \_\_\_\_\_ Door Opens into County Right-of-way \_\_\_\_\_

Fence \_\_\_\_\_ Retaining Wall \_\_\_\_\_

Other X Describe: INSTALL FIBER OPTIC CABINET IN UTILITY R.O.W.

40 POTASK RD. OAKLAND NJ 07436  
Address of Applicant City State Zip  
646-272-0284 (SHAUN) SMAXWELL @ CABLEVISION.COM  
Telephone Number Email

The following must accompany the application:

- Four (4) copies of the property survey/site plan showing and describing in detail the encroachment with dimensions and outside boundaries; and the County of Passaic Right-of-Way Line.
- Photographs clearly showing the existing encroachment. The center of the picture should be oriented along the Right-of-Way line. Note: If any excavation is required in the road or right of way, in addition to this permit please submit a completed Highway Opening and Use Permit Application (FORM: ROAD-HWYOPENPERMITAPP).

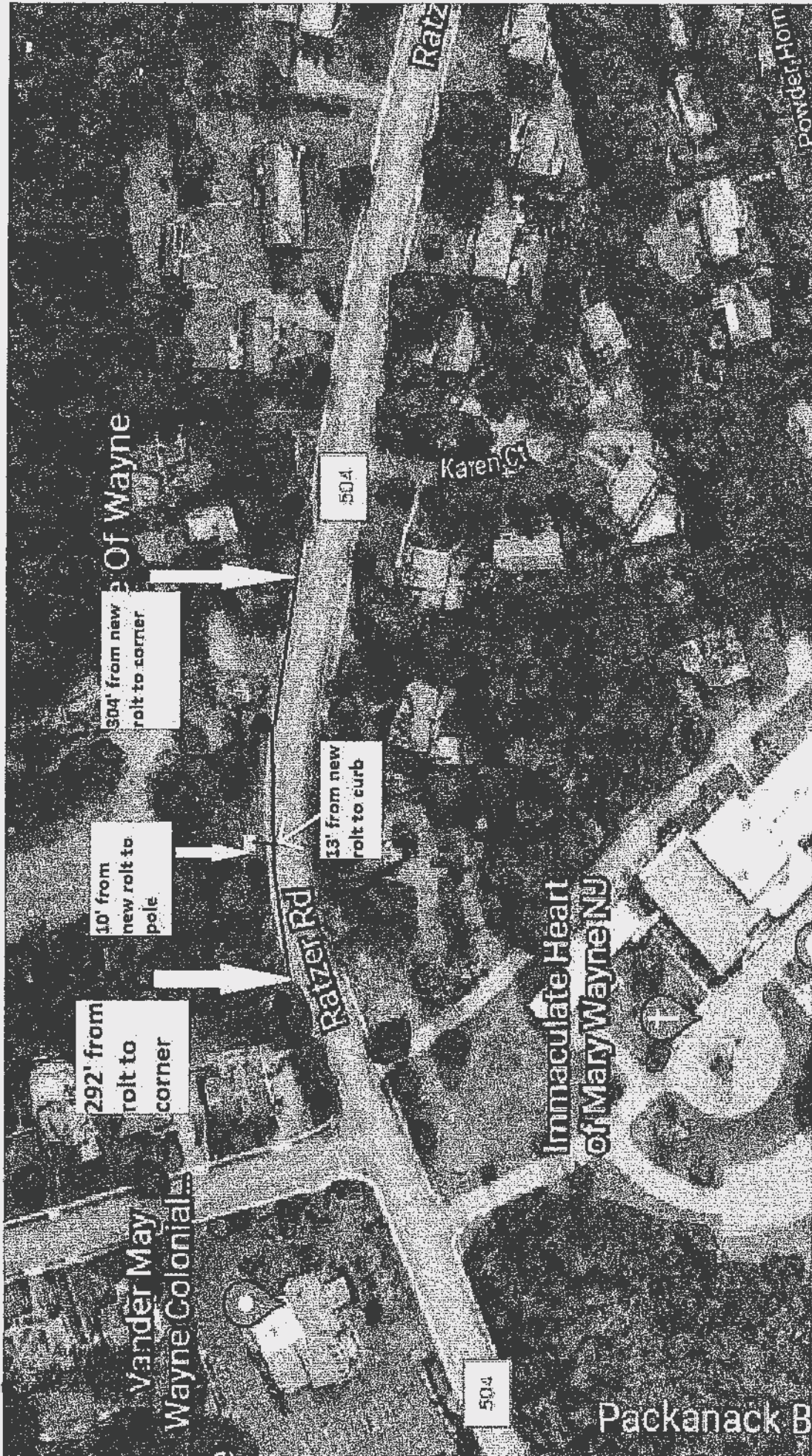

Introduced on:  
Adopted on:  
Official Resolu



# GPON OUTDOOR CABINET 6000

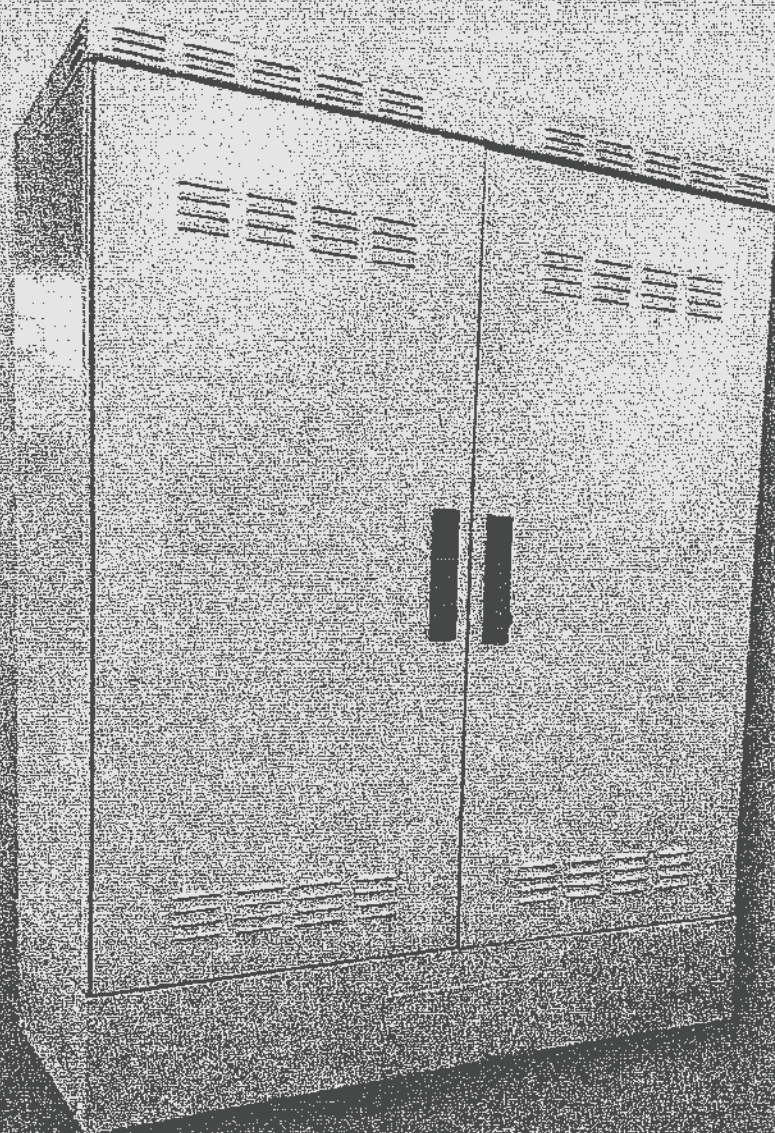

Installation Manual v1.0



### Views of the cabinet GPON Outdoor Cabinet 6000

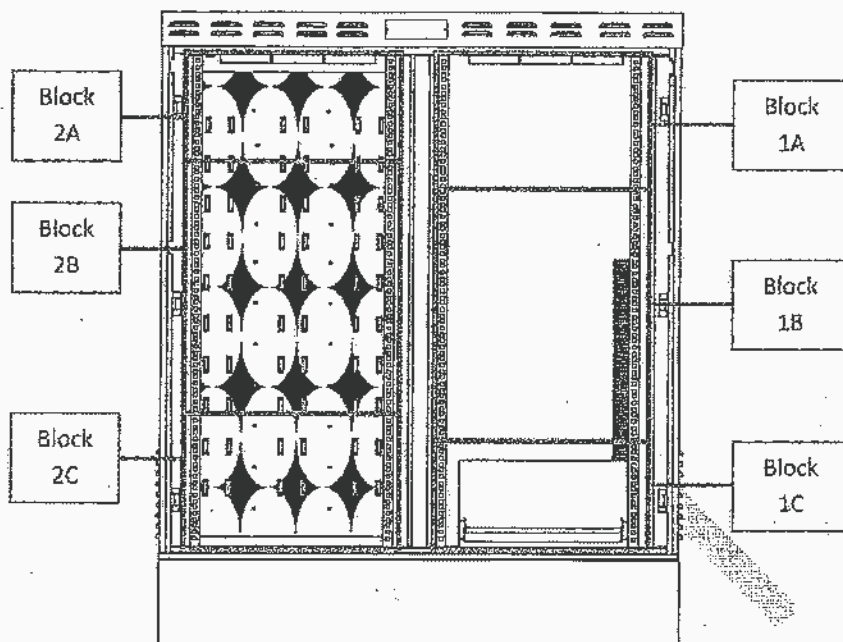

Krone position inside the cabinet.

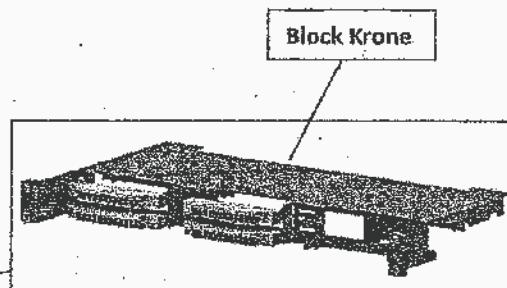
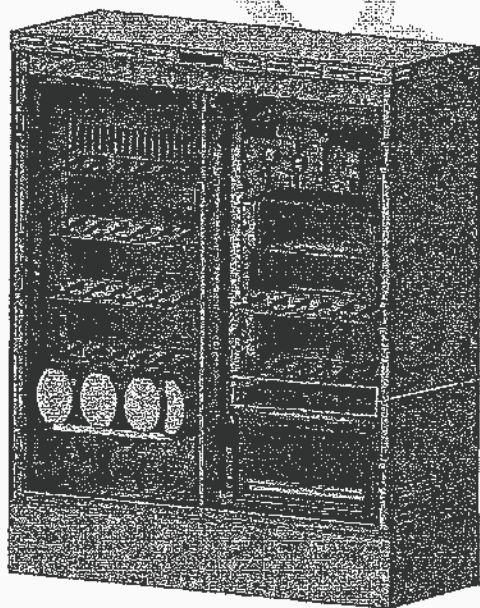

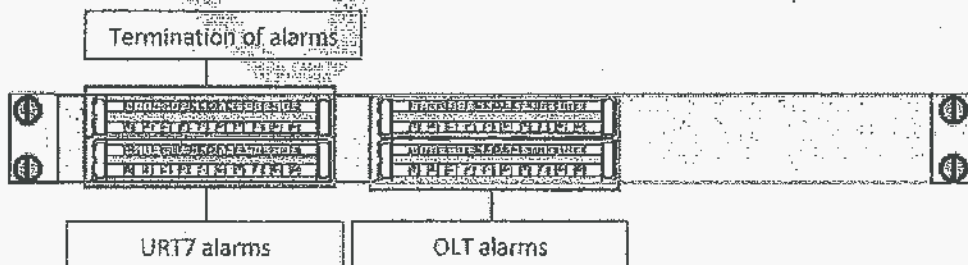
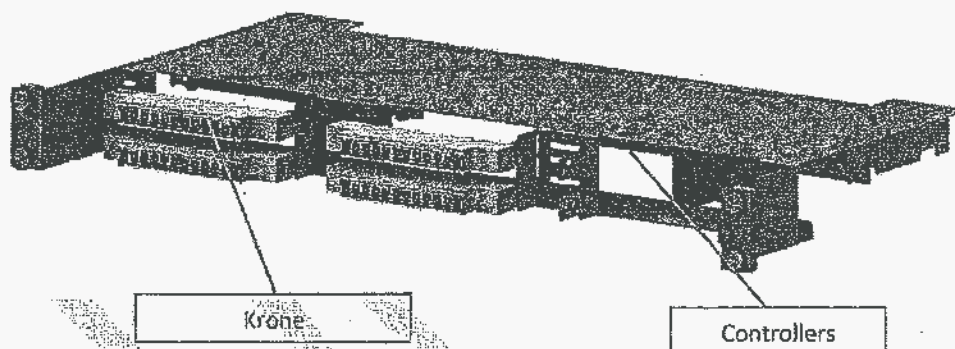
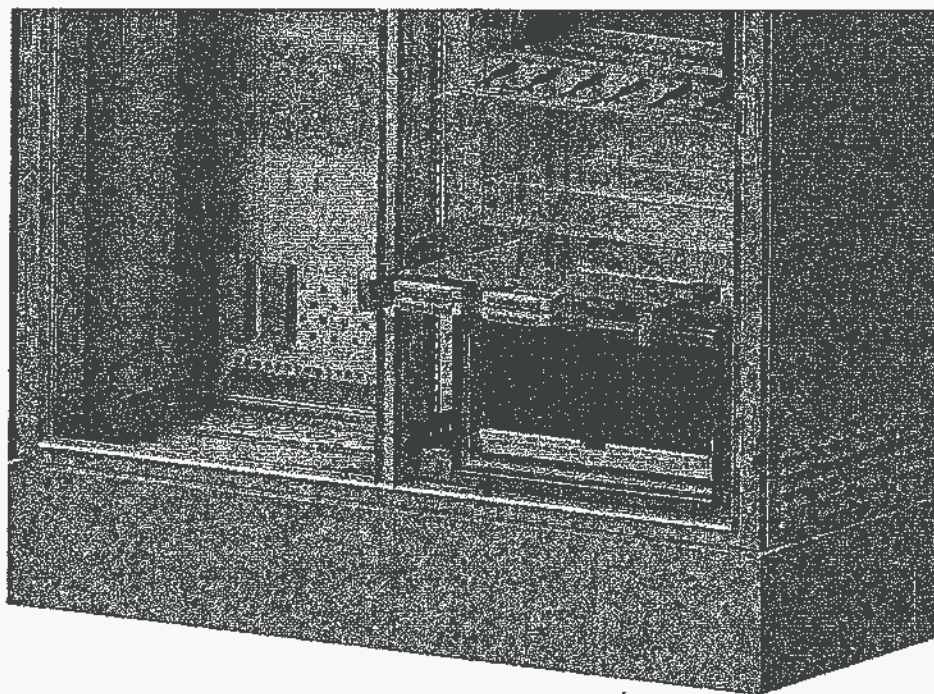

Pedestal installation in solid cement and massive

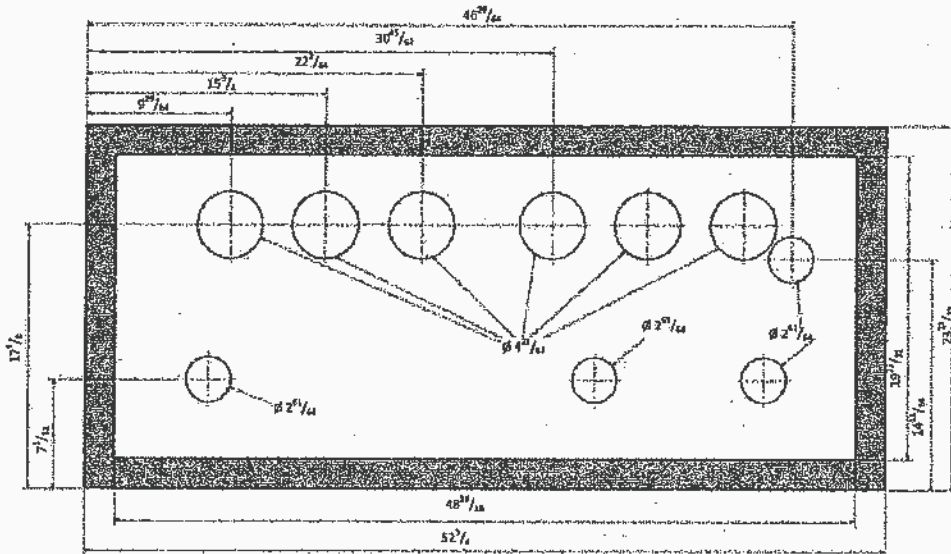

Dimensions of the cabinet (In):  $49\frac{7}{32}$  (W) X  $51\frac{3}{16}$  (H) X  $19\frac{11}{16}$  (D)

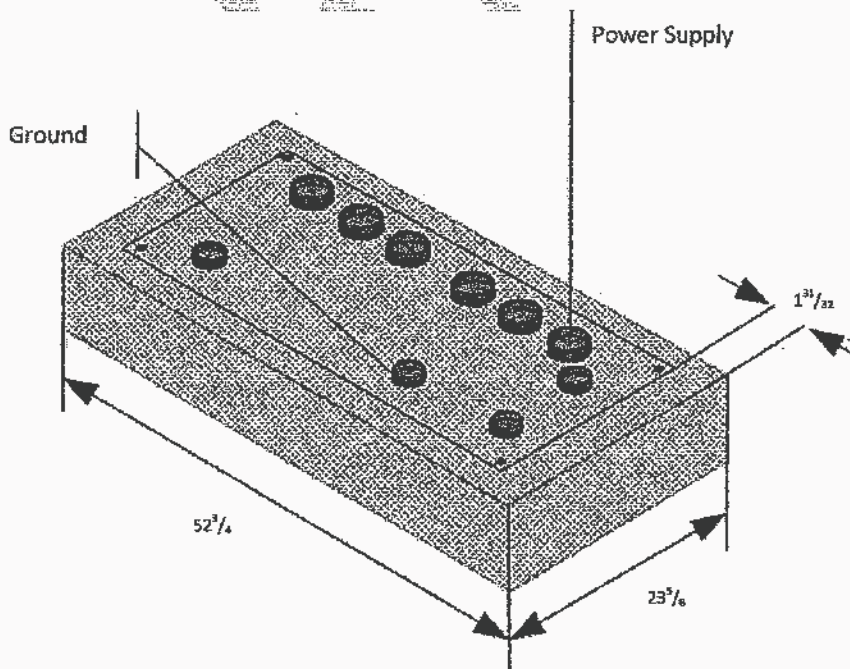

GPON OUTDOOR CABINET 6000 V1.0 / Installation Manual v1.0

### Mounting the pedestal in the "gabarit"

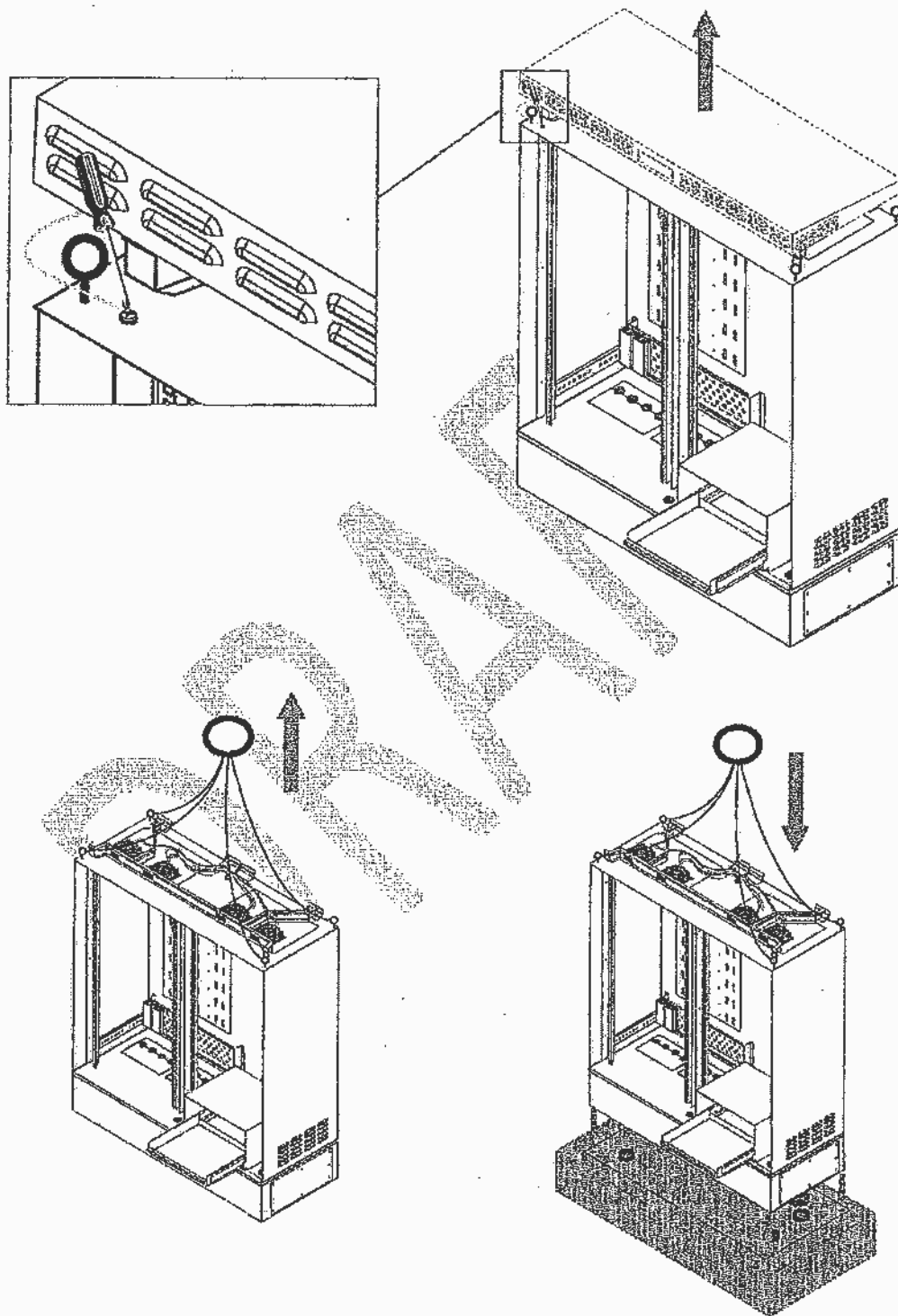

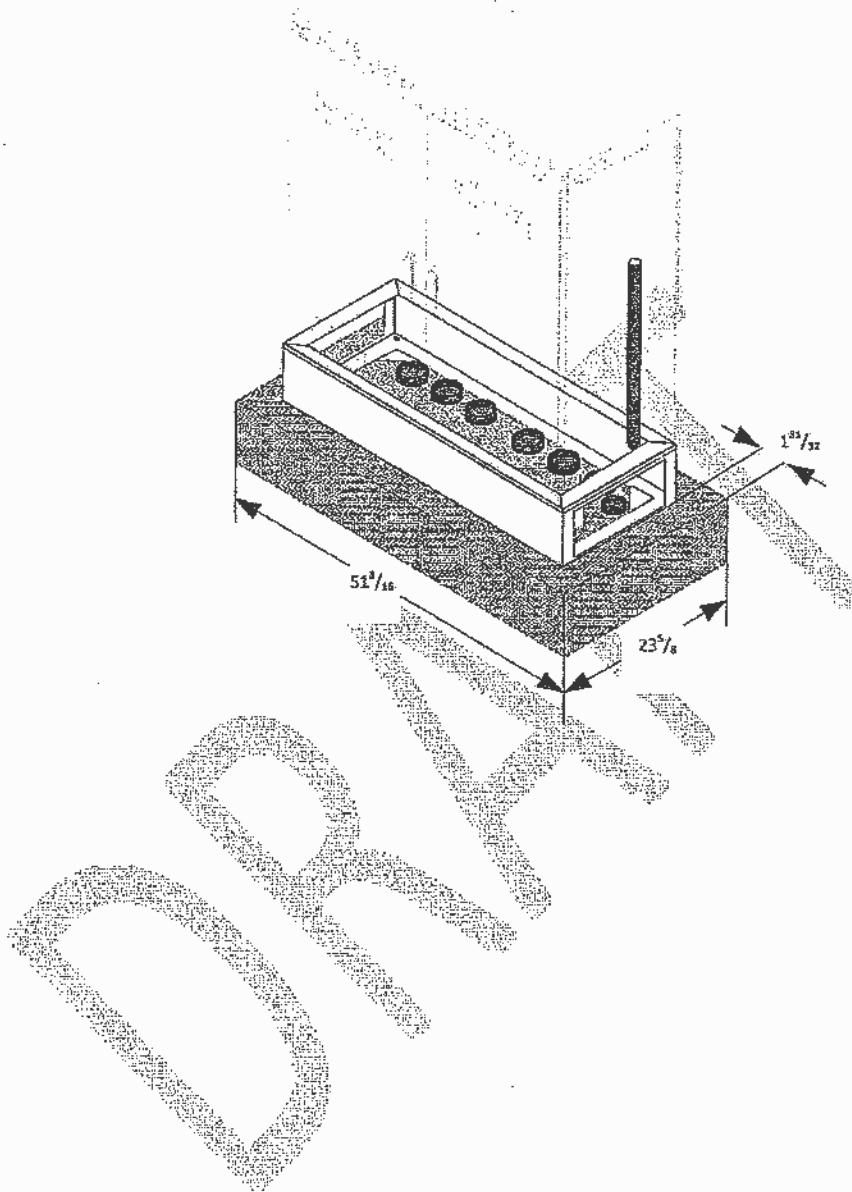

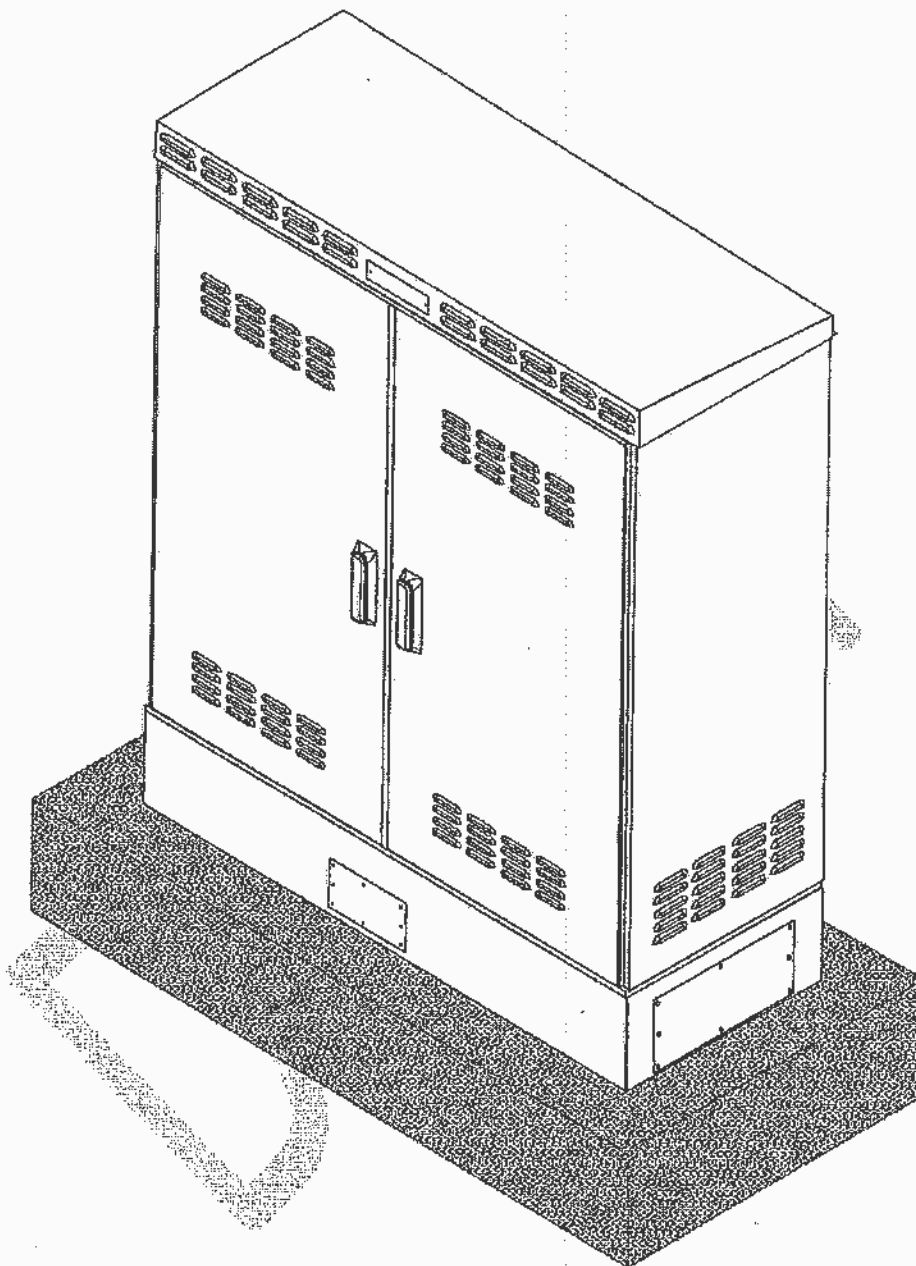

# County of Passaic Board of County Commissioners

OFFICE OF COUNTY COMMISSIONERS

Director Pasquale "Pat" Lepore  
Deputy Director Bruce James  
Assad R. Akhter  
John W. Bartlett  
Theodore O. Best, Jr.  
Terry Duffy  
Cassandra "Sandi" Lazzara

401 Grand Street  
Paterson, New Jersey 07505  
Tel: 973-881-4402  
Fax: 973-742-3746

Anthony J. De Nova III  
*Administrator*  
Matthew P. Jordan, Esq.  
*County Counsel*  
Louis E. Imhof, III, RMC  
*Clerk Of The Board*



## Public Meeting (Board Meeting)

Date: Aug 10, 2021 - 5:30 PM

Location: County Administration Building  
Webex - 220  
401 Grand Street  
Paterson, NJ 07505

Agenda: RESOLUTION AUTHORIZING AWARD OF CONTRACT TO T.R. WENIGER, INC. FOR INSTALLATION OF LOAD BEARING SCREW PILES FOR PREAKNESS VALLEY GOLF COURSE BRIDGES # 6 AND #7, PURSUANT TO N.J.S.A 40A: 11-1, ET SEQ., ALL AS NOTED IN THE RESOLUTION.

THIS RESOLUTION WAS REQUESTED BY:

REVIEWED BY:

Anthony J. De Nova III  
COUNTY ADMINISTRATOR

APPROVED AS TO FORM AND LEGALITY:

Matthew P. Jordan, Esq.  
COUNTY COUNSEL

Public Works

COMMITTEE NAME

<b>Official Resolution#</b>	<b>R20210750</b>							
Meeting Date	08/10/2021							
Introduced Date	08/10/2021							
Adopted Date	08/10/2021							
Agenda Item	I-34							
CAF #	O-21-56-645-003-603							
Purchase Req. #								
Result	Adopted							
<b>COMMISSIONER</b>	<b>PRES.</b>	<b>ABS.</b>	<b>MOVE</b>	<b>SEC</b>	<b>AYE</b>	<b>NAY</b>	<b>ABST.</b>	<b>RECU.</b>
Lepore	✓				✓			
James	✓		✓		✓			
Akhter	✓			✓	✓			
Bartlett	✓				✓			
Best Jr.	✓				✓			
Duffy	✓				✓			
Lazzara	✓				✓			

PRES.= present ABS.= absent  
MOVE= moved SEC= seconded  
AYE= yes NAY= no ABST.= abstain  
RECU.= recuse

Dated: August 11, 2021

**RESOLUTION AUTHORIZING AWARD OF CONTRACT TO T.R. WENIGER, INC. FOR INSTALLATION OF LOAD BEARING SCREW PILES FOR PREAKNESS VALLEY GOLF COURSE BRIDGES # 6 AND #7, PURSUANT TO N.J.S.A. 40A: 11-1, ET SEQ.**

**WHEREAS**, the County of Passaic (hereafter "County") is a government body incorporated pursuant to N.J.S.A. 40:18-1, et seq. and vested with all rights contained therein; and

**WHEREAS**, pursuant to N.J.S.A. 40:20-1, the Board of County Commissioners for the County of Passaic (hereafter "Board") is vested with decision making powers on behalf of the County; and

**WHEREAS**, pursuant to N.J.S.A. 40A:11-4, et seq., every contract awarded by the County, for the provision or performance of any goods or services, the cost of which in the aggregate exceeds the bid threshold [40A:11-3], shall be awarded only by resolution of the Board to the lowest responsible bidder after public advertising for bids and bidding thereof; and

**WHEREAS**, on July 2, 2021, the Purchasing Agent issued C-21-012 Installation of Load Bearing Screw Piles for Preakness Valley Golf Course Bridges #6 and #7, Bid No. C-21-012 (hereafter "C-21-012") seeking sealed proposals from qualified bidders for the installation of load bearing screw piles for golf course bridges# 6 and #7, to be used on an as-needed basis; and

**WHEREAS**, on July 21, 2021, bids were unsealed for C-21-012 by the Purchasing Agent with only (1) response from qualified bidders received from T.R. Weniger, Inc.; and

**WHEREAS**, the County Engineer is recommending an award of contract T.R. Weniger, Inc. for the Installation of Load Bearing Screw Piles for Preakness Valley Golf Course Bridges #6 and #7, and an appropriation of fifty-nine thousand six hundred and ninety dollars (\$59,690.00) to purchase goods and services on an as-need basis; and

**WHEREAS**, the County complied with the legal requirements as set forth under N.J.S.A. 40A:11-23 and the County is making the award of contract within sixty (60) days of the bid opening, as required under N.J.S.A. 40A:11-24(a); and

**WHEREAS**, funds are available in Account No.0-21-56-645-003-603 or any other account that may be deemed appropriate by the Chief Financial Officer or his designee, and the availability of funds has been contingently certified by the Chief Financial Officer subject to sufficient funds being appropriated by the Board in the 2021 and/or subsequent years' County budget (s), which is attached to and made part of this Resolution.

**WHEREAS**, this matter was discussed at the July 28, 2021, Public Works Committee, and is being recommended to the Board for approval.

**NOW, THEREFORE, LET IT BE RESOLVED**, pursuant to N.J.S.A. 40A:11-1, et seq. the Board of County Commissioners of the County of Passaic authorizes an award of contract to T.R. Weniger, Inc. for the Installation of Load Bearing Screw Piles for Preakness Valley Golf Course Bridges # 6 and #7, to be used on an as-needed basis.

**LET IT BE FURTHER RESOLVED**, that the Chief Financial Officer is authorized to appropriate fifty-nine thousand six hundred ninety dollars (\$59,690.00) to be used by the Engineer Department for the installation of load bearing screw piles for golf course bridges # 6 and #7 by T.R. Weniger, Inc., to be used on an as-needed basis.

**LET IT BE FURTHER RESOLVED**, that the Clerk of the Board, County Counsel, Director of the Board of County Commissioners, and Purchasing Agent are authorized to execute an agreement with T.R. Weniger, Inc., and take any other steps necessary to carry out the purpose of this Resolution.

NDA

August 10, 2021



COUNTY OF PASSAIC  
 ENGINEERING DEPT, CO OF PASSAIC  
 (Q) 973-881-4450  
 401 GRAND ST. ROOM 524  
 PATERSON, NJ 07505

REQUISITION	
NO.	R1-13857

S H I P  T O	
V E N D O R	VENDOR #: 12972 T.R. WENIGER, INC. 1900 NEW BRUNSWICK AVENUE PISCATAWAY, NJ 08854

ORDER DATE: 07/27/21  
 DELIVERY DATE:  
 STATE CONTRACT:  
 F.O.B. TERMS:

QTY/UNIT	DESCRIPTION	ACCOUNT NO.	UNIT PRICE	TOTAL COST
1.00 AT	Load Bearing Screw Piles for Preakness Valley Golf Course Bridges 6 & 7 as per Resolution R2021- dated August , 2021  Balance will be encumbered at a later date	0-21-56-645-003-603	29,630.0000	29,630.00
			TOTAL	29,630.00

Introduced on: August 10, 2021  
 Adopted on: August 10, 2021  
 Official Resolution#: R20210750

\_\_\_\_\_  
 REQUESTING DEPARTMENT

\_\_\_\_\_  
 DATE

**CONSTRUCTION BID  
COUNTY OF PASSAIC  
BID TALLY SHEET**

Sherry Arvanitakis, QPA  
Purchasing Agent

Matthew Jordan, Esq.  
County Counsel

Nadège Allwaters, Esq.  
Deputy County Counsel

Taken by: Kevin McDuffie  
Taken by: Tiffany Brown  
Typed by: Tiffany Brown

PROCUREMENT DEPARTMENT

Bids received at July 21, 2021 10:30 AM on at the Passaic County Procurement Center, 495 River Street Second Floor, Paterson, NJ 07524 For:  
**C-21-012 INSTALLATION OF LOAD BEARING SCREW PILES FOR PREAKNESS VALLEY GOLF COURSE BRIDGES #6 AND #7**

Vendor	AGE OF ADDENDA	Disc. Stat. (Excl. D)	New Call AF (Excl. I)	R.B. C.O.G. Ca. Check (Excl. III)	Com. OF Surety (Excl. IV)	DESC I/A II/A	FEDERA L NON- DEBAR CERTIF.	FED. QUEST.	AVAIL. TO CO-OP	PUBLIC WORKS CERTIFICATE		List of Subcontractors	Business Reg. Certificate		Bid Total
										PRIME	SUB		PRIME	SUB	
T.R.WENIGER,INC 1906 NEW BRUNSWICK AVE. PISCATAWAY, NJ 08854		X	X	X	X	X	X	X		12/17/21		NONE	X		TOTAL: \$59,690.00

CERTIFICATION OF AVAILABLE FUNDS

THIS IS TO CERTIFY THAT FUNDS ARE AVAILABLE AS FOLLOWS:

AMOUNT: \$59,690.00

APPROPRIATION: O-21-56-645-003-603

PURPOSE: Award of contract to T.R. Weniger for the installation of load bearing screw piles at Preakness Valley Golf Course.

  
Richard Cahill, Director of Finance

DATED: August 10, 2021

# County of Passaic Board of County Commissioners

OFFICE OF COUNTY COMMISSIONERS

Director Pasquale "Pat" Lepore  
Deputy Director Bruce James  
Assad R. Akhter  
John W. Bartlett  
Theodore O. Best, Jr.  
Terry Duffy  
Cassandra "Sandi" Lazzara

401 Grand Street  
Paterson, New Jersey 07505

Tel: 973-881-4402  
Fax: 973-742-3746

Anthony J. De Nova III  
Administrator

Matthew P. Jordan, Esq.  
County Counsel

Louis E. Imhof, III, RMC  
Clerk Of The Board



## Public Meeting (Board Meeting)

Date: Aug 10, 2021 - 5:30 PM

Location: County Administration Building  
Webex - 220  
401 Grand Street  
Paterson, NJ 07505

Agenda: RESOLUTION AUTHORIZING AN AWARD OF CONTRACT TO NEW PRINCE CONCRETE CONSTRUCTION COMPANY, INC., FOR THE REPLACEMENT OF THE RATZER ROAD CULVERT NO. 1600-367 OVER TRIBUTARY TO POMPTON RIVER IN THE TOWNSHIP OF WAYNE, PURSUANT TO N.J.S.A 40A: 11-1, ET SEQ., ALL AS NOTED IN THE RESOLUTION.

THIS RESOLUTION WAS REQUESTED BY:

REVIEWED BY:

Anthony J. De Nova III  
COUNTY ADMINISTRATOR

APPROVED AS TO FORM AND LEGALITY:

Matthew P. Jordan, Esq.  
COUNTY COUNSEL

Public Works

COMMITTEE NAME

<b>Official Resolution#</b>	<b>R20210751</b>							
Meeting Date	08/10/2021							
Introduced Date	08/10/2021							
Adopted Date	08/10/2021							
Agenda Item	I-35							
CAF #								
Purchase Req. #								
Result	Adopted							
<b>COMMISSIONER</b>	<b>PRES.</b>	<b>ABS.</b>	<b>MOVE</b>	<b>SEC</b>	<b>AYE</b>	<b>NAY</b>	<b>ABST.</b>	<b>RECU.</b>
Lepore	✓				✓			
James	✓		✓		✓			
Akhter	✓			✓	✓			
Bartlett	✓				✓			
Best Jr.	✓				✓			
Duffy	✓				✓			
Lazzara	✓				✓			

PRES.= present ABS.= absent  
 MOVE= moved SEC= seconded  
 AYE= yes NAY= no ABST.= abstain  
 RECU.= recuse

Dated: August 11, 2021

**RESOLUTION AUTHORIZING AN AWARD OF CONTRACT TO NEW PRINCE  
CONCRETE CONSTRUCTION COMPANY, INC., FOR THE REPLACEMENT OF THE  
RATZER ROAD CULVERT NO. 1600-367 OVER TRIBUTARY TO POMPTON RIVER IN  
THE TOWNSHIP OF WAYNE, PURSUANT TO N.J.S.A 40A: 11-1, ET SEQ.**

**WHEREAS**, the County of Passaic (hereafter “County”) is a government body incorporated pursuant to N.J.S.A. 40:18-1, et seq. and vested with all rights contained therein; and

**WHEREAS**, pursuant to N.J.S.A. 40:20-1, the Board of County Commissioners of the County of Passaic (hereafter “Board”) is vested with decision making powers on behalf of the County; and

**WHEREAS**, pursuant to N.J.S.A. 40A:11-4, et seq., every contract awarded by the County, for the provision or performance of any goods or services, the cost of which in the aggregate exceeds the bid threshold [40A:11-3], shall be awarded only by resolution of the Board to the lowest responsible bidder after public advertising for bids and bidding thereof; and

**WHEREAS**, on June 18, 2021, the Purchasing Agent issued Bid No. C-21-005 Replacement of the Ratzler Road Culvert No. 1600-367 Tributary to Pompton River in the Township of Wayne (hereafter “Bid No. C-21-005”) seeking sealed proposals from qualified bidders for Replacement of the Ratzler Road Culvert; and

**WHEREAS**, on July 23, 2021, bids were unsealed for Bid No. C-21-005 by the Purchasing Agent and a total of ten (10) responses were received; and

**WHEREAS**, the County Engineer is recommending an award of contract to New Prince Concrete Construction Company, Inc. for the Replacement of the Ratzler Road Culvert No. 1600-367 in an amount not to exceed nine hundred thirty-four thousand six hundred eighty-three dollars and forty cents (\$964,683.40) which includes the Bid Base (\$934,683.40) plus Alternate Bid #1 (\$30,000.00), as the lowest responsible bidder; and

**WHEREAS**, the County complied with the legal requirements as set forth under N.J.S.A. 40A:11-23 and the County is making the award of contract within sixty (60) days of the bid opening, as required under N.J.S.A. 40A:11-24(a); and

**WHEREAS**, this project is mostly being funded by a 2019 and 2020 NJDOT Local Bridge Fund Grants, and the Township of Wayne will reimburse the County for the cost of the Alternate Bid #1 through a Shared Services Agreement; and

**WHEREAS**, this project is mostly funded by a 2019 and 2020 New Jersey Department of Transportation (hereafter “NJDOT”) Local Bridge Fund Grants and the award is subject to concurring approval of the NJDOT; and

**WHEREAS**, funds are available in an account that may be deemed appropriate by the Chief Financial Officer or his designee, and the availability of funds has been contingently certified by the Chief Financial Officer subject to sufficient funds being appropriated by the Board in the 2021 and/or subsequent years’ County budget(s), which is attached to and made part of this Resolution; and

**WHEREAS**, this matter was discussed at the July 28, 2021, Public Works Committee, and is being recommended to the Board for approval.

**NOW, THEREFORE, LET IT BE RESOLVED**, pursuant to N.J.S.A. 40A:11-1, et seq. the Board of County Commissioners of the County of Passaic authorizes an award of contract to New Prince Concrete Construction Company, Inc. for the Replacement of the Ratzler Road Culvert No. 1600-367 in an amount not to exceed nine hundred thirty-four thousand six hundred eighty-three dollars and forty cents (\$964,683.40) as recommended by the County Engineer.

**LET IT BE FURTHER RESOLVED**, that the Clerk of the Board, County Counsel, and Director of the Board of County Commissioners are authorized to execute an agreement and Form SA-22 Recommendation of Award – State Aid Project, and to take any other steps necessary to carry out the purpose of this Resolution.

NDA

August 10, 2021

REPLACEMENT OF RATZER ROAD BRIDGE OVER TRIBUTARY TO POMPTON RIVER  
 PASSAIC COUNTY STRUCTURE NO. 1800-387  
 TOWNSHIP OF WAYNE IN PASSAIC COUNTY  
 COUNTY PROJECT NO. C-21-005  
 DATE: July 23, 2021

ITEM NO.	DESCRIPTION	UNIT	QUANTITY	UNIT PRICE	Engineer Estimate		New Prince Conc. Constr.		Grade Construction		Colonnelli Brothers, Inc	
					TOTAL	Unit Price	Total	Unit Price	Total	Unit Price	Total	
1	PAYMENT, PERFORMANCE AND MAINTENANCE BOND	DOLLAR	1	\$8,000.00	\$8,000.00	\$9,200.00	\$9,200.00	\$13,933.21	\$13,933.21	\$9,000.00	\$9,000.00	\$9,000.00
2	AS-BUILT PLANS	LS	1	\$5,000.00	\$5,000.00	\$5,000.00	\$5,000.00	\$3,784.12	\$3,784.12	\$1,500.00	\$1,500.00	\$1,500.00
3	PRE-CONSTRUCTION PHOTOGRAPHS	LS	1	\$2,500.00	\$2,500.00	\$1,000.00	\$1,000.00	\$594.65	\$594.65	\$1,000.00	\$1,000.00	\$1,000.00
4	Mobilization	LS	1	\$50,000.00	\$50,000.00	\$85,000.00	\$85,000.00	\$45,281.00	\$45,281.00	\$32,000.00	\$32,000.00	\$52,000.00
5	FIELD OFFICE TYPE D, SET UP	UNIT	1	\$8,000.00	\$8,000.00	\$5,000.00	\$5,000.00	\$16,547.25	\$16,547.25	\$6,000.00	\$6,000.00	\$6,000.00
6	FIELD OFFICE TYPE D, MAINTENANCE	MO	6	\$250.00	\$1,500.00	\$1,000.00	\$6,000.00	\$940.58	\$940.58	\$500.00	\$500.00	\$3,000.00
7	CONSTRUCTION LAYOUT	DOLLAR	1	\$90,000.00	\$90,000.00	\$10,000.00	\$10,000.00	\$13,514.73	\$13,514.73	\$11,000.00	\$11,000.00	\$11,000.00
8	SILT FENCE	LF	248	\$10.99	\$2,480.00	\$9.60	\$2,440.00	\$6.61	\$1,639.28	\$6.00	\$1,488.00	\$1,488.00
9	INLET FILTER, TYPE 1	SF	40	\$30.00	\$1,200.00	\$0.01	\$0.40	\$11.58	\$463.20	\$10.00	\$400.00	\$400.00
10	FLOODING TURBIDITY BARRIER, TYPE 1	LF	20	\$75.00	\$1,500.00	\$1.00	\$20.00	\$91.67	\$1,833.40	\$90.00	\$600.00	\$600.00
11	CONCRETE WASHOUT SYSTEM	LS	1	\$7,500.00	\$7,500.00	\$2,000.00	\$2,000.00	\$4,054.42	\$4,054.42	\$2,000.00	\$2,000.00	\$2,000.00
12	OIL-ONLY EMERGENCY SPILL KIT, TYPE 1	UNIT	1	\$800.00	\$800.00	\$100.00	\$100.00	\$910.88	\$910.88	\$750.00	\$750.00	\$750.00
13	BREAKAWAY BARRICADE	UNIT	11	\$100.00	\$1,100.00	\$100.00	\$1,100.00	\$0.01	\$0.11	\$20.00	\$20.00	\$20.00
14	DUM	UNIT	50	\$30.00	\$1,500.00	\$80.00	\$2,500.00	\$0.01	\$0.50	\$20.00	\$20.00	\$1,000.00
15	TRAFFIC CONE (IF & WHERE DIRECTED)	UNIT	100	\$30.00	\$3,000.00	\$15.00	\$1,500.00	\$0.01	\$0.01	\$10.00	\$10.00	\$1,000.00
16	CONSTRUCTION SIGNS	SF	741	\$90.00	\$66,690.00	\$15.00	\$11,115.00	\$17.84	\$13,219.44	\$14.00	\$10,374.00	\$10,374.00
17	CONSTRUCTION BARRER CURB	LF	120	\$60.00	\$7,200.00	\$7,200.00	\$7,200.00	\$1,995.98	\$1,995.98	\$5,500.00	\$5,500.00	\$5,500.00
18	MODULES	UNIT	1	\$7,000.00	\$7,000.00	\$3,000.00	\$3,000.00	\$1,995.98	\$1,995.98	\$2,500.00	\$2,500.00	\$2,500.00
19	TRAFFIC SAFETY SERVICES	ALLOW	1	\$10,000.00	\$10,000.00	\$10,000.00	\$10,000.00	\$10,000.00	\$10,000.00	\$10,000.00	\$10,000.00	\$10,000.00
20	TRAFFIC DIRECTOR, FLAGGER	HOURLY	100	\$70.00	\$7,000.00	\$75.63	\$7,563.00	\$75.43	\$7,543.00	\$75.53	\$7,553.00	\$7,553.00
21	FINAL CLEANUP	LS	1	\$10,000.00	\$10,000.00	\$5,000.00	\$5,000.00	\$3,095.36	\$3,095.36	\$8,500.00	\$8,500.00	\$8,500.00
22	ASPHALT PRICE ADJUSTMENT	DOLLAR	1	\$10,000.00	\$10,000.00	\$10,000.00	\$10,000.00	\$10,000.00	\$10,000.00	\$10,000.00	\$10,000.00	\$10,000.00
23	CLEARING SITE, BRIDGE	LS	1	\$40,000.00	\$40,000.00	\$40,000.00	\$40,000.00	\$26,935.96	\$26,935.96	\$90,000.00	\$90,000.00	\$90,000.00
24	CLEARING SITE	LS	1	\$50,000.00	\$50,000.00	\$20,000.00	\$20,000.00	\$10,867.97	\$10,867.97	\$45,000.00	\$45,000.00	\$45,000.00
25	EXCAVATION, TEST PIT (IF & WHERE DIRECTED)	CY	90	\$75.00	\$6,750.00	\$1.00	\$90.00	\$98.91	\$8,901.90	\$90.00	\$90.00	\$2,700.00
26	EXCAVATION, UNCLASSIFIED	CY	900	\$50.00	\$45,000.00	\$48.00	\$43,200.00	\$23.11	\$20,799.00	\$52.00	\$46,800.00	\$46,800.00
27	1-4 SOIL AGGREGATE	CY	800	\$90.00	\$72,000.00	\$86.00	\$68,800.00	\$95.65	\$76,520.00	\$95.00	\$76,000.00	\$76,000.00
28	1-4 SOIL AGGREGATE	CY	30	\$25.00	\$750.00	\$25.00	\$750.00	\$195.87	\$5,876.10	\$50.00	\$1,500.00	\$1,500.00
29	COARSE AGGREGATE, SIZE NO. 57	CY	27	\$50.00	\$1,350.00	\$55.00	\$1,485.00	\$94.03	\$2,538.61	\$95.00	\$2,565.00	\$2,565.00
30	DENSE-GRADED AGGREGATE BASE COURSE, 6" THICK	SY	267	\$30.00	\$8,010.00	\$15.00	\$4,005.00	\$22.41	\$5,983.47	\$12.00	\$3,204.00	\$3,204.00
31	HOT MIX ASPHALT 2.5/1.64 BASE COURSE	TON	62	\$125.00	\$7,750.00	\$150.00	\$9,300.00	\$907.01	\$59,054.62	\$181.00	\$11,170.00	\$11,170.00
32	HMA MILLING, 3" OR LESS	SY	350	\$15.00	\$5,250.00	\$15.00	\$5,250.00	\$32.49	\$11,354.90	\$90.00	\$10,800.00	\$10,800.00
33	HOT MIX ASPHALT 9.5/5.64 SURFACE COURSE	TON	60	\$135.00	\$8,100.00	\$180.00	\$10,800.00	\$908.14	\$18,468.40	\$200.00	\$20,000.00	\$20,000.00
34	HOT MIX ASPHALT 12.5/6.4 INTERMEDIATE COURSE	TON	34	\$125.00	\$4,250.00	\$180.00	\$6,120.00	\$308.14	\$10,476.76	\$200.00	\$6,800.00	\$6,800.00
35	TEMPORARY SHEETING	SF	144	\$50.00	\$7,200.00	\$180.00	\$25,920.00	\$191.33	\$27,543.20	\$85.00	\$12,240.00	\$12,240.00
36	NO ITEM											
37	BUDGET IDENTIFICATION PLACQUE, 20" x 30"	UNIT	1	\$4,000.00	\$4,000.00	\$6,000.00	\$6,000.00	\$1,666.25	\$1,666.25	\$1,500.00	\$1,500.00	\$1,500.00
38	PERMANENT SHEETING	SF	1,986	\$50.00	\$99,300.00	\$60.00	\$119,760.00	\$132.28	\$183,380.08	\$85.00	\$168,000.00	\$168,000.00
39	COTTEDBAM	LS	1	\$30,000.00	\$30,000.00	\$25,000.00	\$25,000.00	\$5,827.40	\$5,827.40	\$93,000.00	\$93,000.00	\$93,000.00
40	REINFORCEMENT STEEL	LB	3,400	\$3.00	\$10,200.00	\$4.00	\$13,600.00	\$5.85	\$19,880.00	\$2.00	\$6,800.00	\$6,800.00
41	REINFORCEMENT STEEL, GALVANIZED	LB	2,800	\$2.50	\$7,000.00	\$5.00	\$14,000.00	\$7.52	\$21,056.00	\$3.00	\$8,400.00	\$8,400.00
42	CONCRETE FOOTING	CY	52	\$550.00	\$28,600.00	\$950.00	\$49,400.00	\$470.92	\$24,467.84	\$650.00	\$33,800.00	\$33,800.00
43	CONCRETE WING WALL	CY	29	\$1,000.00	\$29,000.00	\$2,200.00	\$63,800.00	\$1,628.99	\$47,043.86	\$1,250.00	\$36,250.00	\$36,250.00

page 1 of 8

44	BWOY WATERPROOFING	SY	28	\$50.00	\$1,390.00	\$0.00	\$1,390.00	\$0.00	\$0.00	\$0.00	\$0.00	\$0.00	\$92.00	\$0.00	\$0.00	\$92.00
45	CONCRETE Pylon	LF	20	\$500.00	\$10,000.00	\$825.00	\$16,590.00	\$0.00	\$666.29	\$13,337.80	\$0.00	\$1,390.00	\$1,390.00	\$0.00	\$0.00	\$1,390.00
46	PRECAST CONCRETE CURBENT (8' X 2' 3")	LF	50	\$2,500.00	\$12,500.00	\$1,600.00	\$900,000.00	\$0.00	\$2,092.80	\$109,640.00	\$0.00	\$2,550.00	\$127,590.00	\$0.00	\$0.00	\$2,550.00
47	STEEL 4-BAY BRIDGE RAILING	LF	48	\$300.00	\$13,800.00	\$580.00	\$28,680.00	\$0.00	\$551.76	\$35,380.86	\$0.00	\$650.00	\$30,730.86	\$0.00	\$0.00	\$650.00
48	RETAINING WALL LOCATION NO. 3	SF	50	\$100.00	\$5,000.00	\$300.00	\$10,000.00	\$0.00	\$488.00	\$32,904.80	\$0.00	\$126.00	\$3,000.00	\$0.00	\$0.00	\$3,000.00
49	TEMPORARY STRUCTURE, PEDESTRIAN BRIDGE	LS	1	\$40,000.00	\$40,000.00	\$8,000.00	\$5,000.00	\$17,044.82	\$17,044.82	\$42,590.00	\$0.00	\$42,590.00	\$42,590.00	\$0.00	\$0.00	\$42,590.00
50	24" REINFORCED CONCRETE PIPE, CLASS V	LF	44	\$100.00	\$4,400.00	\$150.00	\$6,600.00	\$0.00	\$193.58	\$17,044.82	\$0.00	\$99.00	\$42,590.00	\$0.00	\$0.00	\$42,590.00
51	36" REINFORCED CONCRETE PIPE, CLASS V	LF	95	\$90.00	\$8,550.00	\$128.00	\$11,875.00	\$0.00	\$89.20	\$8,474.00	\$0.00	\$90.00	\$8,550.00	\$0.00	\$0.00	\$8,550.00
52	CONCRETE BRIDGE SIDEWALK	CY	6	\$120.00	\$720.00	\$4,200.00	\$825.00	\$0.00	\$1,046.95	\$6,281.70	\$0.00	\$1,280.00	\$7,500.00	\$0.00	\$0.00	\$7,500.00
53	INLET, TYPE A	UNIT	1	\$3,600.00	\$3,600.00	\$3,000.00	\$3,000.00	\$0.00	\$2,780.06	\$2,780.06	\$0.00	\$3,000.00	\$3,000.00	\$0.00	\$0.00	\$3,000.00
54	INLET, TYPE B	UNIT	1	\$4,000.00	\$4,000.00	\$3,500.00	\$3,500.00	\$0.00	\$3,177.05	\$3,177.05	\$0.00	\$4,250.00	\$4,250.00	\$0.00	\$0.00	\$4,250.00
55	RESET EXISTING CASTING	UNIT	2	\$5,000.00	\$10,000.00	\$7,000.00	\$14,000.00	\$0.00	\$5,584.88	\$11,129.76	\$0.00	\$8,500.00	\$17,000.00	\$0.00	\$0.00	\$17,000.00
56	RESET EXISTING CASTING	UNIT	1	\$500.00	\$500.00	\$500.00	\$500.00	\$0.00	\$1,059.70	\$1,059.70	\$0.00	\$550.00	\$550.00	\$0.00	\$0.00	\$550.00
57	CONCRETE SIDEWALK, 4" THICK	SY	92	\$250.00	\$23,000.00	\$100.00	\$9,200.00	\$0.00	\$54.87	\$5,922.04	\$0.00	\$55.00	\$5,060.00	\$0.00	\$0.00	\$5,060.00
58	HOT MIX ASPHALT DRIVEWAY, VARIABLE THICKNESS	SY	58	\$50.00	\$2,900.00	\$40.00	\$2,320.00	\$0.00	\$54.06	\$3,135.48	\$0.00	\$42.00	\$2,450.00	\$0.00	\$0.00	\$2,450.00
59	DETECTABLE WARNING SURFACE	SY	9	\$350.00	\$3,150.00	\$300.00	\$900.00	\$0.00	\$240.79	\$2,222.87	\$0.00	\$25.00	\$6,050.00	\$0.00	\$0.00	\$6,050.00
60	3"x4" CONCRETE VERTICAL CURB	LF	292	\$50.00	\$14,500.00	\$60.00	\$17,200.00	\$0.00	\$28.38	\$8,298.92	\$0.00	\$3.00	\$1,770.00	\$0.00	\$0.00	\$1,770.00
61	TRAFFIC STRIPES, 4"	LF	590	\$7.00	\$4,130.00	\$3.00	\$1,770.00	\$0.00	\$7.97	\$4,702.30	\$0.00	\$3.00	\$1,770.00	\$0.00	\$0.00	\$1,770.00
62	TRAFFIC STRIPES, 12"	LF	54	\$10.00	\$540.00	\$7.00	\$378.00	\$0.00	\$5.73	\$315.42	\$0.00	\$9.00	\$860.00	\$0.00	\$0.00	\$860.00
63	TRAFFIC MARKINGS SYMBOLS	SF	7	\$20.00	\$140.00	\$25.00	\$175.00	\$0.00	\$21.82	\$151.84	\$0.00	\$22.00	\$486.00	\$0.00	\$0.00	\$486.00
64	RPM BL DIRECTIONAL AMBER LENS	UNIT	3	\$50.00	\$150.00	\$30.00	\$90.00	\$0.00	\$297.32	\$891.96	\$0.00	\$300.00	\$900.00	\$0.00	\$0.00	\$900.00
65	CASH CUSHION, QUADGUARD, 3 BAYS, 24" WIDE	UNIT	2	\$10,000.00	\$20,000.00	\$22,000.00	\$44,000.00	\$0.00	\$19,908.81	\$39,817.62	\$0.00	\$20,000.00	\$40,000.00	\$0.00	\$0.00	\$40,000.00
66	NO ITEM															
67	RESET MANHOLE, SANITARY SEWER, USING EXISTING CASTING	UNIT	2	\$500.00	\$1,000.00	\$800.00	\$1,600.00	\$0.00	\$180.52	\$901.04	\$0.00	\$800.00	\$1,600.00	\$0.00	\$0.00	\$1,600.00
68	8" PERFORATED CORRUGATED HDPE UNDERMAIN PIPE	LF	132	\$70.00	\$9,240.00	\$85.00	\$11,100.00	\$0.00	\$29.35	\$3,874.20	\$0.00	\$5,280.00	\$5,280.00	\$0.00	\$0.00	\$5,280.00
69	TOPSOIL SPREADING, 4" THICK	SY	36	\$5.00	\$180.00	\$10.00	\$360.00	\$0.00	\$24.94	\$897.84	\$0.00	\$7.00	\$252.00	\$0.00	\$0.00	\$252.00
70	FERTILIZING AND SEEDING, TYPE A-3	SY	36	\$5.00	\$180.00	\$1.00	\$36.00	\$0.00	\$3.97	\$144.82	\$0.00	\$4.00	\$144.86	\$0.00	\$0.00	\$144.86
71	STRAW MULCHING	SY	36	\$5.00	\$180.00	\$1.00	\$36.00	\$0.00	\$3.27	\$117.72	\$0.00	\$4.00	\$144.89	\$0.00	\$0.00	\$144.89
72	SMALL DECIDUOUS TREES 2-2 1/2" CALIPER	UNIT	3	\$750.00	\$2,250.00	\$900.00	\$2,700.00	\$0.00	\$2,829.09	\$8,487.27	\$0.00	\$1,000.00	\$3,000.00	\$0.00	\$0.00	\$3,000.00
BASE BID TOTAL					\$897,540.00	\$934,683.40	\$934,683.40	\$0.00	\$958,423.52	\$988,000.00	\$0.00	\$0.00	\$0.00	\$0.00	\$0.00	\$0.00
Bid Proposal Number Read at Bid Opening					\$94,893.40	\$94,893.40	\$94,893.40	\$0.00	\$94,893.40	\$94,893.40	\$0.00	\$0.00	\$0.00	\$0.00	\$0.00	\$0.00
Bid Proposal minus Spreadsheet Total					\$0.00	\$0.00	\$0.00	\$0.00	\$0.00	\$0.00	\$0.00	\$0.00	\$0.00	\$0.00	\$0.00	\$0.00
ALTERNATE #1 BID TOTAL					\$150,000.00	\$150,000.00	\$150,000.00	\$0.00	\$29,232.45	\$29,232.45	\$0.00	\$0.00	\$0.00	\$0.00	\$0.00	\$0.00
BASE BID PLUS ALT #1 TOTAL					\$1,197,540.00	\$1,129,683.40	\$1,129,683.40	\$0.00	\$987,655.97	\$1,083,186.85	\$0.00	\$0.00	\$0.00	\$0.00	\$0.00	\$0.00

Reviewing Engineer:   
 Date Received: July 23, 2021  
 Date Reviewed: July 28, 2021  
 Jonathan Para, P.E.  
 County Engineer

PAGE 2 OF 53

REPLACEMENT OF RATZER ROAD BRIDGE OVER TRIBUTARY TO POMPTON RIVER

PASSAIC COUNTY STRUCTURE NO. 1600-367  
 TOWNSHIP OF WAYNE IN PASSAIC COUNTY  
 COUNTY PROJECT NO. C-21-009

DATE: July 23, 2021

ITEM NO.	DESCRIPTION	UNIT	QUANTITY	UNIT PRICE	TOTAL	Engineer Estimate		Rohman E&G Corp.		Sparwick Contracting Inc		Underground Utilities Corp.	
						Unit Price	Total	Unit Price	Total	Unit Price	Total	Unit Price	Total
1	PAYMENT, PERFORMANCE AND MAINTENANCE BOND	DOLLAR	1	\$8,000.00	\$8,000.00								
2	AS-BUILT PLANS	L5	1	\$5,000.00	\$5,000.00	\$1,000.00	\$1,000.00	\$1,800.00	\$1,800.00	\$1,800.00	\$1,800.00	\$7,000.00	\$7,000.00
3	PRE-CONSTRUCTION PHOTOGRAPHS	L5	1	\$2,500.00	\$2,500.00	\$1,000.00	\$1,000.00	\$500.00	\$500.00	\$1,750.00	\$1,750.00	\$1,750.00	\$1,750.00
4	MOBILIZATION	L5	1	\$50,000.00	\$50,000.00	\$110,000.00	\$110,000.00	\$125,000.00	\$125,000.00	\$125,000.00	\$125,000.00	\$175,000.00	\$175,000.00
5	FIELD OFFICE TYPE D, SET UP	UNIT	1	\$8,000.00	\$8,000.00	\$12,000.00	\$12,000.00	\$7,500.00	\$7,500.00	\$7,500.00	\$7,500.00	\$16,000.00	\$16,000.00
6	FIELD OFFICE TYPE D, MAINTENANCE	MO	6	\$250.00	\$1,500.00	\$5,000.00	\$5,000.00	\$1,500.00	\$9,000.00	\$1,500.00	\$9,000.00	\$1,500.00	\$9,000.00
7	CONSTRUCTION LAYOUT	DOLLAR	1	\$50,000.00	\$50,000.00	\$15,000.00	\$15,000.00	\$15,000.00	\$15,000.00	\$10,000.00	\$10,000.00	\$15,000.00	\$15,000.00
8	SILT FENCE	LF	248	\$10.00	\$2,480.00	\$8.00	\$1,984.00	\$2.00	\$496.00	\$2.00	\$496.00	\$4.00	\$992.00
9	HALET FILTER, TYPE 1	SF	40	\$30.00	\$1,200.00	\$8.00	\$320.00	\$10.00	\$400.00	\$15.00	\$600.00	\$15.00	\$600.00
10	FLOATING TURBIDITY BARRIER, TYPE 1	LF	20	\$75.00	\$1,500.00	\$35.00	\$700.00	\$13.00	\$260.00	\$20.00	\$400.00	\$20.00	\$400.00
11	CONCRETE WASHOUT SYSTEM	L5	1	\$7,500.00	\$7,500.00	\$5,800.00	\$5,800.00	\$9,500.00	\$9,500.00	\$9,500.00	\$9,500.00	\$9,500.00	\$9,500.00
12	OIL-DIUT, EMERGENCY SPILL KIT, TYPE 1	UNIT	1	\$100.00	\$1,100.00	\$140.00	\$140.00	\$1,400.00	\$1,400.00	\$1,400.00	\$1,400.00	\$2,475.00	\$2,475.00
13	BREAKAWAY BARRICADE	UNIT	11	\$80.00	\$880.00	\$176.00	\$1,936.00	\$16.00	\$176.00	\$1.00	\$11.00	\$1.00	\$11.00
14	DRUM	UNIT	50	\$30.00	\$1,500.00	\$76.00	\$3,800.00	\$1.00	\$50.00	\$1.00	\$50.00	\$125.00	\$6,250.00
15	TRAFFIC CONE (IF & WHERE DIRECTED)	UNIT	100	\$80.00	\$8,000.00	\$17.00	\$1,700.00	\$16.00	\$1,600.00	\$1.00	\$100.00	\$1.00	\$100.00
16	CONSTRUCTION SIGNS	SF	741	\$30.00	\$22,230.00	\$17.00	\$12,597.00	\$16.00	\$11,856.00	\$1.00	\$741.00	\$1.00	\$741.00
17	CONSTRUCTION BARRIER CURB	LF	220	\$60.00	\$13,200.00	\$176.00	\$38,720.00	\$9.00	\$1,980.00	\$75.00	\$16,500.00	\$75.00	\$16,500.00
18	MODULES	UNIT	1	\$7,000.00	\$7,000.00	\$3,000.00	\$3,000.00	\$9,500.00	\$9,500.00	\$9,500.00	\$9,500.00	\$4,500.00	\$4,500.00
19	TRAFFIC SAFETY SERVICES	ALLOW	1	\$10,000.00	\$10,000.00	\$10,000.00	\$10,000.00	\$10,000.00	\$10,000.00	\$10,000.00	\$10,000.00	\$10,000.00	\$10,000.00
20	TRAFFIC DIRECTOR, FLAGGER	HOURL	100	\$70.00	\$7,000.00	\$75.53	\$7,553.00	\$75.53	\$7,553.00	\$75.53	\$7,553.00	\$75.53	\$7,553.00
21	FINAL CLEANUP	L5	1	\$10,000.00	\$10,000.00	\$5,400.00	\$5,400.00	\$6,000.00	\$6,000.00	\$6,000.00	\$6,000.00	\$25,000.00	\$25,000.00
22	ASPHALT PRICE ADJUSTMENT	DOLLAR	1	\$10,000.00	\$10,000.00	\$10,000.00	\$10,000.00	\$10,000.00	\$10,000.00	\$10,000.00	\$10,000.00	\$10,000.00	\$10,000.00
23	CLEARING SITE, BRIDGE	L5	1	\$40,000.00	\$40,000.00	\$100,000.00	\$100,000.00	\$75,000.00	\$75,000.00	\$75,000.00	\$75,000.00	\$85,000.00	\$85,000.00
24	CLEARING SITE	L5	1	\$50,000.00	\$50,000.00	\$25,000.00	\$25,000.00	\$125,000.00	\$125,000.00	\$125,000.00	\$125,000.00	\$40,000.00	\$40,000.00
25	EXCAVATION, TEST PIT (IF & WHERE DIRECTED)	CY	90	\$75.00	\$6,750.00	\$1.00	\$90.00	\$25.00	\$2,250.00	\$25.00	\$2,250.00	\$90.00	\$27,000.00
26	EXCAVATION, UNCLASSIFIED	CY	900	\$50.00	\$45,000.00	\$10.00	\$9,000.00	\$30.00	\$27,000.00	\$30.00	\$27,000.00	\$30.00	\$27,000.00
27	1-4 SOIL AGGREGATE	CY	900	\$50.00	\$45,000.00	\$20.00	\$18,000.00	\$40.00	\$36,000.00	\$45.00	\$40,500.00	\$45.00	\$40,500.00
28	1-4 SOIL AGGREGATE	CY	30	\$26.00	\$780.00	\$60.00	\$1,800.00	\$40.00	\$1,200.00	\$45.00	\$1,350.00	\$45.00	\$1,350.00
29	COARSE AGGREGATE, SITE NO. 57	SY	27	\$50.00	\$1,350.00	\$50.00	\$1,350.00	\$60.00	\$1,620.00	\$60.00	\$1,620.00	\$125.00	\$3,375.00
30	DENSE-GRADED AGGREGATE BASE COURSE, 6" THICK	SY	267	\$20.00	\$5,340.00	\$18.00	\$4,806.00	\$10.00	\$2,670.00	\$15.00	\$4,005.00	\$15.00	\$4,005.00
31	HOT MIX ASPHALT ZEMBA BASE COURSE	TON	62	\$125.00	\$7,750.00	\$200.00	\$12,400.00	\$295.00	\$18,290.00	\$295.00	\$18,290.00	\$300.00	\$18,600.00
32	HMA MILLING, 3" OR LESS	SY	350	\$15.00	\$5,250.00	\$15.00	\$5,250.00	\$35.00	\$12,250.00	\$35.00	\$12,250.00	\$35.00	\$12,250.00
33	HOT MIX ASPHALT 5.5MID SURFACE COURSE	TON	60	\$150.00	\$9,000.00	\$220.00	\$13,200.00	\$290.00	\$17,400.00	\$290.00	\$17,400.00	\$375.00	\$22,500.00
34	HOT MIX ASPHALT 12.5MID INTERMEDIATE COURSE	TON	34	\$125.00	\$4,250.00	\$320.00	\$10,880.00	\$290.00	\$9,860.00	\$290.00	\$9,860.00	\$375.00	\$12,750.00
35	TEMPORARY SHEETING	SF	144	\$50.00	\$7,200.00	\$800.00	\$115,200.00	\$50.00	\$7,200.00	\$50.00	\$7,200.00	\$200.00	\$28,800.00
36	NO ITEM	UNIT	1	\$4,000.00	\$4,000.00	\$3,000.00	\$3,000.00	\$3,500.00	\$3,500.00	\$3,500.00	\$3,500.00	\$4,500.00	\$4,500.00
37	BRIDGE IDENTIFICATION PLAQUE, 20" x 30"	SF	1,386	\$50.00	\$69,300.00	\$30.00	\$41,580.00	\$55.00	\$76,230.00	\$55.00	\$76,230.00	\$75.00	\$103,950.00
38	PERMANENT SHEETING	L5	1	\$30,000.00	\$30,000.00	\$15,000.00	\$15,000.00	\$182,500.00	\$182,500.00	\$182,500.00	\$182,500.00	\$50,000.00	\$50,000.00
39	COFFERDAM	LB	3,400	\$2.00	\$6,800.00	\$2.50	\$8,500.00	\$1.75	\$5,950.00	\$3.00	\$10,200.00	\$3.00	\$10,200.00
40	REINFORCEMENT STEEL	LB	2,800	\$2.50	\$7,000.00	\$3.00	\$8,400.00	\$2.25	\$6,300.00	\$2.50	\$7,000.00	\$2.50	\$7,000.00
41	REINFORCEMENT STEEL, GALVANIZED	CY	52	\$16,000.00	\$832,000.00	\$1,000.00	\$52,000.00	\$250.00	\$13,000.00	\$250.00	\$13,000.00	\$800.00	\$41,600.00
42	CONCRETE FOOTING	CY	24	\$1,000.00	\$24,000.00	\$1,700.00	\$40,800.00	\$250.00	\$6,000.00	\$250.00	\$6,000.00	\$800.00	\$19,200.00
43	CONCRETE WING WALL	CY	24	\$1,000.00	\$24,000.00	\$1,700.00	\$40,800.00	\$250.00	\$6,000.00	\$250.00	\$6,000.00	\$800.00	\$19,200.00

PAGE 3 OF 8

Introduced on: August 10, 2021  
 Adopted on: August 10, 2021  
 Official Resolution#: R20210751



44	EPOXY WATERPROOFING	SY	26	\$50.00	\$1,300.00	\$1.00	\$26.00	\$60.00	\$1,560.00	\$50.00	\$1,390.00
45	CONCRETE PAVEN	LF	20	\$500.00	\$10,000.00	\$230.00	\$4,600.00	\$415.00	\$8,800.00	\$700.00	\$14,000.00
46	PRECAST CONCRETE CULVERT (8 X 7.5')	LF	50	\$2,000.00	\$1,000,000.00	\$2,200.00	\$110,000.00	\$2,590.00	\$2,590,000.00	\$3,000.00	\$150,000.00
47	STEEL 4-BAR BRIDGE RAILING	LF	46	\$300.00	\$13,800.00	\$350.00	\$9,500.00	\$345.00	\$15,870.00	\$425.00	\$20,000.00
48	RETAINING WALL, LOCATION NO. 1	SF	50	\$100.00	\$5,000.00	\$105.00	\$4,950.00	\$290.00	\$3,250.00	\$290.00	\$10,000.00
49	TEMPORARY STRUCTURE, PEDESTALIAN BRIDGE	LS	1	\$40,000.00	\$40,000.00	\$30,000.00	\$30,000.00	\$18,000.00	\$18,000.00	\$16,000.00	\$16,000.00
50	24" REINFORCED CONCRETE PIPE, CLASS V	LF	44	\$100.00	\$4,400.00	\$150.00	\$6,600.00	\$135.00	\$5,940.00	\$125.00	\$5,500.00
51	18" REINFORCED CONCRETE PIPE, CLASS V	LF	95	\$90.00	\$8,550.00	\$125.00	\$11,875.00	\$100.00	\$9,500.00	\$125.00	\$11,875.00
52	CONCRETE BRIDGE SIDEWALK	CY	5	\$700.00	\$3,500.00	\$370.00	\$2,220.00	\$1,200.00	\$7,200.00	\$1,900.00	\$11,400.00
53	INLET, TYPE A	UNIT	1	\$3,600.00	\$3,600.00	\$4,230.00	\$4,230.00	\$3,000.00	\$3,000.00	\$4,000.00	\$4,000.00
54	INLET, TYPE B	UNIT	1	\$4,000.00	\$4,000.00	\$4,800.00	\$4,800.00	\$3,500.00	\$3,500.00	\$4,000.00	\$4,000.00
55	INLET, TYPE DOUBLE B	UNIT	2	\$5,000.00	\$10,000.00	\$5,100.00	\$10,200.00	\$4,500.00	\$9,000.00	\$7,800.00	\$15,000.00
56	RESET EXISTING CASTING	UNIT	1	\$500.00	\$500.00	\$340.00	\$340.00	\$900.00	\$900.00	\$1,000.00	\$1,000.00
57	CONCRETE SIDEWALK, 4" THICK	SY	92	\$250.00	\$23,000.00	\$75.00	\$6,900.00	\$75.00	\$6,900.00	\$80.00	\$8,280.00
58	HOT MIX ASPHALT DRIVEWAY, VARIABLE THICKNESS	SY	58	\$50.00	\$2,900.00	\$72.00	\$4,176.00	\$60.00	\$3,480.00	\$80.00	\$3,480.00
59	DETECTABLE WARNING SURFACE	SY	3	\$390.00	\$1,170.00	\$140.00	\$426.00	\$390.00	\$1,170.00	\$200.00	\$600.00
60	9" X 18" CONCRETE VERTICAL CURB	LF	242	\$50.00	\$12,100.00	\$80.00	\$19,280.00	\$32.00	\$7,744.00	\$35.00	\$8,470.00
61	TRAFFIC STRIPES, 4"	LF	590	\$7.00	\$4,130.00	\$3.50	\$2,065.00	\$4.00	\$2,360.00	\$3.50	\$2,065.00
62	TRAFFIC STRIPES, 12"	LF	54	\$10.00	\$540.00	\$10.00	\$540.00	\$6.00	\$324.00	\$8.50	\$459.00
63	TRAFFIC MARKINGS SYMBOLS	SF	7	\$20.00	\$140.00	\$22.00	\$154.00	\$15.00	\$105.00	\$22.00	\$154.00
64	RPM, BI-DIRECTIONAL, AMBER LENS	UNIT	3	\$50.00	\$150.00	\$50.00	\$90.00	\$300.00	\$900.00	\$300.00	\$900.00
65	CRASH CUSHION, GUARDRAIL, 3 BAYS, 24" WIDE	UNIT	2	\$10,000.00	\$20,000.00	\$30,000.00	\$60,000.00	\$18,500.00	\$37,000.00	\$24,000.00	\$48,000.00
66	NO ITEM										
67	RESET MANHOLE, SANITARY SEWER, USING EXISTING CASTING	UNIT	2	\$800.00	\$1,600.00	\$340.00	\$680.00	\$460.00	\$920.00	\$1,500.00	\$3,000.00
68	8" PERFORATED CORRUGATED HDPE UNDERDRAIN PIPE	LF	132	\$70.00	\$9,240.00	\$15.00	\$1,980.00	\$26.00	\$3,432.00	\$50.00	\$6,600.00
69	TOPSOIL, SPREADING, 4" THICK	SY	30	\$5.00	\$1,500.00	\$5.00	\$1,500.00	\$20.00	\$720.00	\$16.00	\$496.00
70	FERTILIZING AND SEEDING, TYPE A-3	SY	36	\$5.00	\$180.00	\$0.50	\$18.00	\$3.00	\$108.00	\$10.00	\$360.00
71	STRAW MULCHING	SY	36	\$5.00	\$180.00	\$0.50	\$18.00	\$3.00	\$108.00	\$10.00	\$360.00
72	SMALL DECIDUOUS TREE, 2-2 1/2" CALIBER	UNIT	3	\$750.00	\$2,250.00	\$480.00	\$1,440.00	\$1,200.00	\$3,600.00	\$1,000.00	\$3,000.00
BASE BID TOTAL					\$897,540.00	\$1,127,879.00	\$1,127,879.00	0.00	1,142,191.00	\$1,243,621.60	\$1,243,621.60
Bid Proposal Number Read at Bid Opening						\$0.00					
Bid Proposal minus Spreadsheet Total											
A1.1	12" DUCTILE IRON WATER PIPE, CLASS 52	LS	1	\$150,000.00	\$150,000.00	\$60,000.00	\$60,000.00		\$192,000.00	\$95,000.00	\$35,000.00
ALTERNATE #1 BID TOTAL					\$150,000.00	\$60,000.00			\$192,000.00	\$95,000.00	\$35,000.00
BASE BID PLUS ALT #1 TOTAL					\$1,137,540.00	\$1,187,879.00			\$1,142,191.00	\$1,278,621.60	\$1,278,621.60

Reviewing Engineer: *Jonathan Pera, P.E.*  
 Date Received: July 23, 2021  
 Date Reviewed: July 28, 2021  
 County Engineer

Page 4 of 8

REPLACEMENT OF RATZER ROAD BRIDGE OVER TRIBUTARY TO POMPTON RIVER  
 PASSAIC COUNTY STRUCTURE NO. 1500-387  
 TOWNSHIP OF WAYNE IN PASSAIC COUNTY  
 COUNTY PROJECT NO. C-21-008

DATE: July 23, 2021

ITEM NO.	DESCRIPTION	UNIT	QUANTITY	Engineer Estimate		Martyro, Inc		Persistent Const. Inc.		CRS Contractors, Inc.	
				UNIT PRICE	TOTAL	Unit Price	Total	Unit Price	Total	Unit Price	Total
1	PAYMENT PERFORMANCE AND MAINTENANCE BOND	DOLLAR	1	\$8,000.00	\$8,000.00	\$8,000.00	\$8,000.00	\$14,300.00	\$14,300.00	\$20,000.00	\$20,000.00
2	AS-BUILT PLANS	LS	1	\$3,000.00	\$3,000.00	\$3,000.00	\$3,000.00	\$5,000.00	\$5,000.00	\$5,000.00	\$5,000.00
3	PRE-CONSTRUCTION PHOTOGRAPHS	LS	1	\$2,500.00	\$2,500.00	\$1,500.00	\$1,500.00	\$1,500.00	\$1,500.00	\$5,000.00	\$5,000.00
4	MOBILIZATION	LS	1	\$50,000.00	\$50,000.00	\$114,045.00	\$114,045.00	\$61,000.00	\$61,000.00	\$100,000.00	\$100,000.00
5	FIELD OFFICE TYPE D, SET UP	UNIT	1	\$8,000.00	\$8,000.00	\$20,000.00	\$20,000.00	\$5,000.00	\$5,000.00	\$20,000.00	\$20,000.00
6	FIELD OFFICE TYPE D, MAINTENANCE	MO	6	\$250.00	\$1,500.00	\$2,000.00	\$12,000.00	\$2,500.00	\$15,000.00	\$5,000.00	\$30,000.00
7	CONSTRUCTION LAYOUT	DOLLAR	1	\$50,000.00	\$50,000.00	\$15,000.00	\$15,000.00	\$15,950.00	\$15,950.00	\$30,000.00	\$30,000.00
8	SILT FENCE	LF	248	\$10.00	\$2,480.00	\$5.00	\$1,240.00	\$4.00	\$992.00	\$15.00	\$3,720.00
9	INLET FILTER, TYPE 1	SF	40	\$30.00	\$1,200.00	\$1.00	\$40.00	\$60.00	\$2,400.00	\$30.00	\$1,200.00
10	FLOATING TURBIDITY BARRIER, TYPE 1	LF	20	\$75.00	\$1,500.00	\$50.00	\$1,000.00	\$20.00	\$400.00	\$60.00	\$1,200.00
11	CONCRETE WASHOUT SYSTEM	LS	1	\$7,500.00	\$7,500.00	\$2,500.00	\$2,500.00	\$1,150.00	\$1,150.00	\$4,000.00	\$4,000.00
12	ON-ONLY EMERGENCY SPILL KIT, TYPE 1	UNIT	1	\$800.00	\$800.00	\$900.00	\$900.00	\$400.00	\$400.00	\$1,000.00	\$1,000.00
13	BREAKAWAY BARRICADE	UNIT	11	\$100.00	\$1,100.00	\$100.00	\$1,100.00	\$40.00	\$440.00	\$100.00	\$1,100.00
14	DRUM	UNIT	50	\$80.00	\$4,000.00	\$60.00	\$3,000.00	\$35.00	\$1,750.00	\$50.00	\$2,500.00
15	TRAFFIC CONE (IF & WHERE DIRECTED)	UNIT	100	\$90.00	\$9,000.00	\$1.00	\$100.00	\$10.00	\$1,000.00	\$15.00	\$1,500.00
16	CONSTRUCTION SIGNS	SF	741	\$30.00	\$22,230.00	\$15.00	\$11,115.00	\$15.00	\$11,115.00	\$20.00	\$14,820.00
17	CONSTRUCTION BARRIER CURB	LF	120	\$60.00	\$7,200.00	\$15.00	\$1,800.00	\$26.00	\$3,120.00	\$60.00	\$7,200.00
18	MODULES	UNIT	1	\$7,000.00	\$7,000.00	\$5,000.00	\$5,000.00	\$8,000.00	\$8,000.00	\$6,000.00	\$6,000.00
19	TRAFFIC SAFETY SERVICES	ALLOW	1	\$10,000.00	\$10,000.00	\$10,000.00	\$10,000.00	\$10,000.00	\$10,000.00	\$10,000.00	\$10,000.00
20	TRAFFIC DIRECTOR, FLAGGER	HOURL	100	\$70.00	\$7,000.00	\$75.53	\$7,553.00	\$75.53	\$7,553.00	\$75.53	\$7,553.00
21	PAINT CLEANUP	LS	1	\$10,000.00	\$10,000.00	\$5,000.00	\$5,000.00	\$4,300.00	\$4,300.00	\$6,000.00	\$6,000.00
22	ASPHALT PRICE ADJUSTMENT	DOLLAR	1	\$10,000.00	\$10,000.00	\$10,000.00	\$10,000.00	\$10,000.00	\$10,000.00	\$10,000.00	\$10,000.00
23	CLEARING SITE, BRIDGE	LS	1	\$40,000.00	\$40,000.00	\$60,000.00	\$60,000.00	\$69,962.00	\$69,962.00	\$80,000.00	\$80,000.00
24	CLEARING SITE	LS	1	\$50,000.00	\$50,000.00	\$35,000.00	\$35,000.00	\$50,000.00	\$50,000.00	\$22,000.00	\$22,000.00
25	EXCAVATION, TEST PIT (IF & WHERE DIRECTED)	CY	90	\$75.00	\$6,750.00	\$1.00	\$90.00	\$175.00	\$15,750.00	\$250.00	\$22,500.00
26	EXCAVATION, UNCLASSIFIED	CY	900	\$50.00	\$45,000.00	\$5.00	\$4,500.00	\$81.00	\$72,900.00	\$80.00	\$72,000.00
27	1-1/4 SOIL AGGREGATE	CY	900	\$50.00	\$45,000.00	\$5.00	\$4,500.00	\$81.00	\$72,900.00	\$80.00	\$72,000.00
28	1-1/4 SOIL AGGREGATE	CY	30	\$35.00	\$1,050.00	\$50.00	\$1,500.00	\$310.00	\$9,300.00	\$80.00	\$2,400.00
29	COARSE AGGREGATE, SIZE NO. 57	CY	27	\$90.00	\$2,430.00	\$10.00	\$270.00	\$297.00	\$8,118.00	\$120.00	\$3,240.00
30	DENSE-GRADED AGGREGATE BASE COURSE, 6" THICK	SY	267	\$20.00	\$5,340.00	\$27.00	\$7,209.00	\$45.00	\$12,015.00	\$22.00	\$5,874.00
31	HOT MIX ASPHALT 2.5% SMA BASE COURSE	TON	62	\$115.00	\$7,130.00	\$225.00	\$13,950.00	\$275.00	\$17,050.00	\$170.00	\$10,540.00
32	HMA MILLING, 3" OR LESS	SY	350	\$15.00	\$5,250.00	\$30.00	\$10,500.00	\$23.00	\$8,050.00	\$10.00	\$3,500.00
33	HOT MIX ASPHALT 9.5% SMA SURFACE COURSE	TON	60	\$150.00	\$9,000.00	\$250.00	\$15,000.00	\$275.00	\$16,500.00	\$220.00	\$13,200.00
34	HOT MIX ASPHALT 12.5% SMA INTERMEDIATE COURSE	TON	34	\$125.00	\$4,250.00	\$300.00	\$10,200.00	\$275.00	\$9,350.00	\$180.00	\$6,120.00
35	TEMPORARY SHEETING	SF	144	\$50.00	\$7,200.00	\$1.00	\$144.00	\$2,085.00	\$300,240.00	\$280.00	\$40,320.00
36	NO ITEM										
37	BRIDGE IDENTIFICATION PLaque, 20" x 30"	UNIT	1	\$4,000.00	\$4,000.00	\$3,000.00	\$3,000.00	\$2,050.00	\$2,050.00	\$4,500.00	\$4,500.00
38	PERMANENT SHEETING	SF	1,986	\$50.00	\$99,300.00	\$85.00	\$171,810.00	\$10.00	\$19,860.00	\$125.00	\$248,250.00
39	COFFERDAM	LS	1	\$30,000.00	\$30,000.00	\$40,000.00	\$40,000.00	\$22,050.00	\$22,050.00	\$55,000.00	\$55,000.00
40	REINFORCEMENT STEEL	LB	3,400	\$2.00	\$6,800.00	\$4.00	\$13,600.00	\$2.10	\$7,140.00	\$2.50	\$8,500.00
41	REINFORCEMENT STEEL, GALVANIZED	LB	2,800	\$2.50	\$7,000.00	\$5.00	\$14,000.00	\$2.90	\$8,120.00	\$3.00	\$8,400.00
42	CONCRETE FOOTING	CY	52	\$650.00	\$33,800.00	\$900.00	\$46,800.00	\$1,060.00	\$55,120.00	\$980.00	\$51,040.00
43	CONCRETE WING WALL	CY	24	\$1,000.00	\$24,000.00	\$1,200.00	\$28,800.00	\$2,680.00	\$64,320.00	\$1,800.00	\$43,200.00

PALE SEE B

Introduced on: August 10, 2021  
 Adopted on: August 10, 2021  
 Official Resolution#: R20210751

44	EPDM WATERPROOFING	SY	26	\$50.00	\$1,300.00	\$100.00	\$2,600.00	\$1.00	\$16.000.00	\$1.00	\$16.000.00	\$16.00	\$29,800.00	\$70.00	\$1,820.00	
45	CONCRETE PAVEN	LF	20	\$500.00	\$10,000.00	\$800.00	\$16,000.00	\$1,490.00	\$29,800.00	\$1,490.00	\$29,800.00	\$700.00	\$14,000.00	\$14,000.00	\$14,000.00	
46	PRECAST CONCRETE CULVERT (8' X 7.5')	LF	50	\$2,500.00	\$125,000.00	\$2,500.00	\$125,000.00	\$2,740.00	\$137,000.00	\$2,740.00	\$137,000.00	\$2,700.00	\$135,000.00	\$135,000.00	\$135,000.00	
47	STEEL 4-BAR BRIDGE RAILING	LF	46	\$300.00	\$13,800.00	\$450.00	\$20,700.00	\$455.00	\$20,950.00	\$455.00	\$20,950.00	\$445.00	\$19,000.00	\$19,000.00	\$19,000.00	
48	RETAINING WALL, LOCATION NO. 1	SF	50	\$100.00	\$5,000.00	\$200.00	\$10,000.00	\$170.00	\$8,500.00	\$170.00	\$8,500.00	\$170.00	\$8,500.00	\$8,500.00	\$8,500.00	
49	TEMPORARY STRUCTURE, PEDESTRIAN BRIDGE	LS	1	\$40,000.00	\$40,000.00	\$50,000.00	\$24,200.00	\$24,200.00	\$24,200.00	\$24,200.00	\$24,200.00	\$20,000.00	\$20,000.00	\$20,000.00	\$20,000.00	
50	24" REINFORCED CONCRETE PIPE, CLASS V	LF	44	\$100.00	\$4,400.00	\$180.00	\$7,920.00	\$170.00	\$7,480.00	\$170.00	\$7,480.00	\$275.00	\$12,500.00	\$12,500.00	\$12,500.00	
51	18" REINFORCED CONCRETE PIPE, CLASS V	LF	95	\$80.00	\$7,600.00	\$85.00	\$8,075.00	\$99.00	\$9,405.00	\$99.00	\$9,405.00	\$250.00	\$23,750.00	\$23,750.00	\$23,750.00	
52	CONCRETE BRIDGE SIDEWALK	LY	6	\$700.00	\$4,200.00	\$800.00	\$4,800.00	\$940.00	\$5,640.00	\$940.00	\$5,640.00	\$730.00	\$7,300.00	\$7,300.00	\$7,300.00	
53	INLET, TYPE A	UNIT	1	\$3,800.00	\$3,800.00	\$3,300.00	\$3,300.00	\$2,710.00	\$2,710.00	\$2,710.00	\$2,710.00	\$5,000.00	\$5,000.00	\$5,000.00	\$5,000.00	
54	INLET, TYPE B	UNIT	1	\$4,000.00	\$4,000.00	\$5,000.00	\$5,000.00	\$4,160.00	\$4,160.00	\$4,160.00	\$4,160.00	\$8,000.00	\$8,000.00	\$8,000.00	\$8,000.00	
55	RESET EXISTING CASTINGS	UNIT	2	\$6,000.00	\$12,000.00	\$6,500.00	\$13,000.00	\$5,890.00	\$11,780.00	\$5,890.00	\$11,780.00	\$1,000.00	\$1,000.00	\$1,000.00	\$1,000.00	
56	RESET EXISTING CASTINGS	UNIT	1	\$300.00	\$300.00	\$650.00	\$650.00	\$675.00	\$675.00	\$675.00	\$675.00	\$1,000.00	\$1,000.00	\$1,000.00	\$1,000.00	
57	CONCRETE SIDEWALK, 4" THICK	SY	92	\$250.00	\$23,000.00	\$125.00	\$11,500.00	\$105.00	\$9,660.00	\$105.00	\$9,660.00	\$150.00	\$13,800.00	\$13,800.00	\$13,800.00	
58	HOT MIX ASPHALT DRIVEWAY, VARIABLE THICKNESS	SY	58	\$50.00	\$2,900.00	\$60.00	\$3,480.00	\$45.00	\$2,610.00	\$45.00	\$2,610.00	\$80.00	\$4,640.00	\$4,640.00	\$4,640.00	
59	DETECTABLE WARNING SURFACE	SY	9	\$380.00	\$3,420.00	\$300.00	\$2,700.00	\$325.00	\$2,925.00	\$325.00	\$2,925.00	\$500.00	\$1,500.00	\$1,500.00	\$1,500.00	
60	5" X 8" CONCRETE VERTICAL CURB	LF	242	\$50.00	\$12,100.00	\$40.00	\$9,680.00	\$48.00	\$11,664.00	\$48.00	\$11,664.00	\$1.00	\$1,100.00	\$1,100.00	\$1,100.00	
61	TRAFFIC STRIPES, 4"	LF	590	\$7.00	\$4,130.00	\$7.00	\$4,130.00	\$3.50	\$2,065.00	\$3.50	\$2,065.00	\$3.00	\$1,770.00	\$1,770.00	\$1,770.00	
62	TRAFFIC STRIPES, 12"	LF	54	\$10.00	\$540.00	\$7.00	\$378.00	\$11.00	\$594.00	\$11.00	\$594.00	\$3.00	\$162.00	\$162.00	\$162.00	
63	TRAFFIC MARKINGS SYMBOLS	SF	7	\$20.00	\$140.00	\$20.00	\$140.00	\$20.00	\$140.00	\$20.00	\$140.00	\$6.00	\$42.00	\$42.00	\$42.00	
64	RPM, BIDIRECTIONAL AMBER LENS	UNIT	3	\$50.00	\$150.00	\$50.00	\$150.00	\$320.00	\$960.00	\$320.00	\$960.00	\$100.00	\$300.00	\$300.00	\$300.00	
65	CRASH CUSHION GUARDRAIL, 3 BAYS, 24" WIDE	UNIT	2	\$10,000.00	\$20,000.00	\$25,000.00	\$50,000.00	\$11,750.00	\$23,500.00	\$11,750.00	\$23,500.00	\$18,075.00	\$37,200.00	\$37,200.00	\$37,200.00	
66	NO ITEM															
67	RESET MANHOLE, SANITARY SEWER, USING EXISTING CASTING	UNIT	2	\$500.00	\$1,000.00	\$550.00	\$1,100.00	\$600.00	\$1,200.00	\$600.00	\$1,200.00	\$1,000.00	\$2,000.00	\$2,000.00	\$2,000.00	
68	8" PERFORATED CORRUGATED HDPE UNDERDRAIN PIPE	LF	132	\$70.00	\$9,240.00	\$40.00	\$5,280.00	\$53.00	\$7,056.00	\$53.00	\$7,056.00	\$50.00	\$6,600.00	\$6,600.00	\$6,600.00	
69	TOPSOIL SPREADING, 4" THICK	SY	36	\$5.00	\$180.00	\$50.00	\$1,800.00	\$4.00	\$1,440.00	\$4.00	\$1,440.00	\$40.00	\$1,600.00	\$1,600.00	\$1,600.00	
70	FERTILIZING AND SEEDING, TYPE A-3	SY	36	\$5.00	\$180.00	\$1.00	\$36.00	\$1.00	\$36.00	\$1.00	\$36.00	\$2.00	\$72.00	\$72.00	\$72.00	
71	STRAW MULCHING	SY	36	\$5.00	\$180.00	\$2.00	\$72.00	\$1.00	\$36.00	\$1.00	\$36.00	\$1.00	\$36.00	\$36.00	\$36.00	
72	SMALL DECIDUOUS TREE, 2-2 1/2" CALIPER	UNIT	3	\$750.00	\$2,250.00	\$2,000.00	\$6,000.00	\$1,210.00	\$3,630.00	\$1,210.00	\$3,630.00	\$1,000.00	\$3,000.00	\$3,000.00	\$3,000.00	
BASE BID TOTAL					\$887,540.00	\$1,291,117.00	\$1,291,117.00	\$1,291,117.00	\$1,291,117.00	\$1,291,117.00	\$1,291,117.00	\$1,397,250.00	\$1,397,250.00	\$1,397,250.00	\$1,397,250.00	
Bid Proposal Number Read at Bid Opening																
Bid Proposal minus Spreadsheet Total							0.00									
A1-1	12" DUCTILE IRON WATER PIPE, CLASS S2	LS	1	\$150,000.00	\$150,000.00	\$50,000.00	\$50,000.00	\$50,000.00	\$50,000.00	\$50,000.00	\$50,000.00	\$44,650.00	\$44,650.00	\$44,650.00	\$44,650.00	
ALTERNATE #1 BID TOTAL					\$150,000.00	\$50,000.00	\$50,000.00	\$50,000.00	\$50,000.00	\$50,000.00	\$50,000.00	\$44,650.00	\$44,650.00	\$44,650.00	\$44,650.00	
BASE BID PLUS ALT #1 TOTAL					\$1,317,540.00	\$1,341,117.00	\$1,341,117.00	\$1,341,117.00	\$1,341,117.00	\$1,341,117.00	\$1,341,117.00	\$1,397,250.00	\$1,397,250.00	\$1,397,250.00	\$1,397,250.00	\$1,397,250.00

Reviewing Engineer: *[Signature]*  
 Date Received: July 23, 2021  
 Date Reviewed: July 28, 2021  
 Jonathan Pera, P.E.  
 County Engineer

PAGE 6 OF 8

REPLACEMENT OF FATZER ROAD BRIDGE OVER TRIBUTARY TO POMPTON RIVER  
 PASSAIC COUNTY STRUCTURE NO. 1600-367  
 TOWNSHIP OF WAYNE IN PASSAIC COUNTY  
 COUNTY PROJECT NO. C-21-805

DATE: July 23, 2021

ITEM NO.	DESCRIPTION	UNIT	QUANTITY	Engineer Estimate		CMS Construction, Inc		Total
				UNIT PRICE	TOTAL	Unit Price	Total	
1	PAYMENT, PERFORMANCE AND MAINTENANCE BOND	DOLLAR	1	\$8,000.00	\$8,000.00	\$12,800.00	\$12,800.00	
2	AS-BUILT PLANS	LS	1	\$5,000.00	\$5,000.00	\$4,500.00	\$4,500.00	
3	PRE-CONSTRUCTION PHOTOGRAPHS	LS	1	\$3,500.00	\$3,500.00	\$1,000.00	\$1,500.00	
4	MOBILIZATION	LS	1	\$50,000.00	\$50,000.00	\$35,000.00	\$35,000.00	
5	FIELD OFFICE TYPE D, SET UP	UNIT	1	\$8,000.00	\$8,000.00	\$1,000.00	\$1,000.00	
6	FIELD OFFICE TYPE D, MAINTENANCE	MO	6	\$250.00	\$1,500.00	\$500.00	\$3,000.00	
7	CONSTRUCTION LAYOUT	DOLLAR	1	\$50,000.00	\$50,000.00	\$16,500.00	\$16,500.00	
8	SILT FENCE	LF	248	\$30.00	\$7,440.00	\$4.00	\$992.00	
9	INLET FILTER, TYPE 1	SF	40	\$30.00	\$1,200.00	\$10.00	\$400.00	
10	FLOATING TURBIDITY BARRIER, TYPE 1	LF	20	\$75.00	\$1,500.00	\$50.00	\$1,000.00	
11	CONCRETE WASHOUT SYSTEM	LS	1	\$7,500.00	\$7,500.00	\$2,000.00	\$2,000.00	
12	OIL-ONLY EMERGENCY SPILL KIT, TYPE 1	UNIT	1	\$800.00	\$800.00	\$500.00	\$500.00	
13	BREAKAWAY BARRICADE	UNIT	11	\$100.00	\$1,100.00	\$200.00	\$2,200.00	
14	TRAFIC CONE (E & WHERE DIRECTED)	UNIT	50	\$30.00	\$1,500.00	\$150.00	\$7,500.00	
15	CONSTRUCTION SIGNS	SF	741	\$30.00	\$22,230.00	\$18.00	\$13,338.00	
16	CONSTRUCTION BARRIER CURB	LF	120	\$60.00	\$7,200.00	\$50.00	\$6,000.00	
17	TRAFFIC SAFETY SERVICES	ALLOW	1	\$7,000.00	\$7,000.00	\$5,000.00	\$10,000.00	
18	TRAFFIC DIRECTOR, FLAGGER	HOURL	100	\$70.00	\$7,000.00	\$75.50	\$7,550.00	
19	SIGNAL CLEANUP	LS	1	\$10,000.00	\$10,000.00	\$2,000.00	\$2,000.00	
20	ASPHALT PRICE ADJUSTMENT	LS	1	\$10,000.00	\$10,000.00	\$10,000.00	\$10,000.00	
21	CLEARING SITE, BRIDGE	LS	1	\$40,000.00	\$40,000.00	\$90,000.00	\$90,000.00	
22	CLEARING SITE	LS	1	\$50,000.00	\$50,000.00	\$24,000.00	\$24,000.00	
23	EXCAVATION, TEST PIT (E & WHERE DIRECTED)	CY	90	\$75.00	\$6,750.00	\$100.00	\$9,000.00	
24	EXCAVATION, UNCLASSIFIED	CY	900	\$50.00	\$45,000.00	\$45.00	\$40,500.00	
25	1-14 SOIL AGGREGATE	CY	900	\$82.500.00	\$74,250.00	\$40.00	\$36,000.00	
26	DENSE-GRADED AGGREGATE BASE COURSE, 6" THICK	TON	257	\$125.00	\$32,125.00	\$120.00	\$30,840.00	
27	HMA MILLING, 3" OR LESS	SY	350	\$15.00	\$5,250.00	\$25.00	\$8,750.00	
28	HOT MIX ASPHALT 25MSD BASE COURSE	TON	60	\$150.00	\$9,000.00	\$95.00	\$5,700.00	
29	HOT MIX ASPHALT 12.5MSD INTERMEDIATE COURSE	TON	34	\$125.00	\$4,250.00	\$230.00	\$7,820.00	
30	TEMPORARY SHEETING	SF	144	\$50.00	\$7,200.00	\$65.00	\$9,360.00	
31	BRIDGE IDENTIFICATION PLAQUE, 20" x 30"	UNIT	1	\$4,000.00	\$4,000.00	\$8,500.00	\$12,500.00	
32	PERMANENT SHEETING	SF	1,386	\$50.00	\$69,300.00	\$85.00	\$117,810.00	
33	COFFERDAM	LS	1	\$30,000.00	\$30,000.00	\$10,000.00	\$10,000.00	
34	REINFORCEMENT STEEL	LB	3,400	\$2.00	\$6,800.00	\$3.00	\$10,200.00	
35	REINFORCEMENT STEEL, GALVANIZED	LB	2,800	\$2.50	\$7,000.00	\$4.00	\$11,200.00	
36	CONCRETE FOOTING	CY	52	\$16,900.00	\$878,800.00	\$780.00	\$39,960.00	
37	CONCRETE WING WALL	CY	24	\$1,000.00	\$24,000.00	\$900.00	\$21,600.00	

Page 7 of 6

44	EPoxy WATERPROOFING	SY	25	\$50.00	\$1,250.00	\$65.00	\$1,690.00		
45	CONCRETE PAVEN	LF	20	\$500.00	\$10,000.00	\$650.00	\$13,000.00		
46	PRECAST CONCRETE CURBVERT (8' X 7.5')	LF	50	\$2,500.00	\$125,000.00	\$7,150.00	\$109,000.00		
47	STEEL 4-96# BRIDGE RAILINGS	LF	46	\$800.00	\$36,800.00	\$395.00	\$18,170.00		
48	RETAINING WALL, LOCATION NO. 1	SF	50	\$100.00	\$5,000.00	\$450.00	\$22,500.00		
49	TEMPORARY STRUCTURE, PEDESTRIAN BRIDGE	LS	1	\$40,000.00	\$40,000.00	\$22,000.00	\$22,000.00		
50	24" REINFORCED CONCRETE PIPE CLASS V	LF	44	\$100.00	\$4,400.00	\$145.00	\$6,380.00		
51	18" REINFORCED CONCRETE PIPE CLASS V	LF	95	\$90.00	\$8,550.00	\$140.00	\$13,300.00		
52	CONCRETE BRIDGE SIDEWALK	CY	6	\$700.00	\$4,200.00	\$1,000.00	\$5,000.00		
53	INLET, TYPE A	UNIT	1	\$3,600.00	\$3,600.00	\$4,000.00	\$4,000.00		
54	INLET, TYPE B	UNIT	1	\$4,000.00	\$4,000.00	\$4,000.00	\$4,000.00		
55	INLET, TYPE DOUBLE B	UNIT	2	\$5,000.00	\$10,000.00	\$9,000.00	\$10,000.00		
56	RESET EXISTING CASTING	UNIT	1	\$500.00	\$500.00	\$1,200.00	\$1,200.00		
57	CONCRETE SIDEWALK, 4" THICK	SY	92	\$250.00	\$23,000.00	\$75.00	\$6,900.00		
58	HOT MIX ASPHALT DRIVEWAY, VARIABLE THICKNESS	SY	58	\$50.00	\$2,900.00	\$55.00	\$3,170.00		
59	DETECTABLE WARNING SURFACE	SY	3	\$350.00	\$1,050.00	\$750.00	\$2,190.00		
60	9" X 18" CONCRETE VERTICAL CURB	LF	242	\$50.00	\$12,100.00	\$45.00	\$10,900.00		
61	TRAFFIC STRIPES, 4"	LF	350	\$7.00	\$2,450.00	\$4.00	\$2,800.00		
62	TRAFFIC STRIPES, 12"	LF	34	\$10.00	\$340.00	\$12.00	\$408.00		
63	TRAFFIC MARKINGS SYMBOLS	SF	7	\$20.00	\$140.00	\$15.00	\$105.00		
64	RPM, BIDIRECTIONAL, AMBER LENS	UNIT	3	\$50.00	\$150.00	\$250.00	\$750.00		
65	CRASH CUSHION, GUARDRAIL, 3 BAYS, 24" WIDE	UNIT	2	\$10,000.00	\$20,000.00	\$21,000.00	\$42,000.00		
66	NO ITEM								
67	RESET MANHOLE, SANITARY SEWER, USING EXISTING CASTING	UNIT	2	\$500.00	\$1,000.00	\$500.00	\$1,000.00		
68	3" REINFORCED CORRUGATED HDPE UNDERDRAIN PIPE	LF	132	\$70.00	\$9,240.00	\$35.00	\$3,800.00		
69	TOPSOIL SPREADING, 4" THICK	SY	35	\$5.00	\$1,750.00	\$16.00	\$575.00		
70	FERTILIZING AND SEEDING, TYPE A-3	SY	35	\$5.00	\$1,750.00	\$4.00	\$140.00		
71	STRAW MULCHING	SY	35	\$5.00	\$1,750.00	\$1.00	\$35.00		
72	SMALL DECIDUOUS TREE, 2 1/2" CALIPER	UNIT	3	\$750.00	\$2,250.00	\$350.00	\$1,050.00		
BASE BID TOTAL					\$987,540.00		\$889,161.00		
Bid Proposal Number Read at Bid Opening							\$889,161.00		
Bid Proposal Initial Spreadsheet Total							\$0.00		
A1-1	12" DUCTILE IRON WATER PIPE, CLASS 52	LS	1	\$150,000.00	\$150,000.00				
ALTERNATE #1 BID TOTAL					\$150,000.00				
BASE BID PLUS ALT #1 TOTAL					\$1,137,540.00				
						No Alternate Bid Submitted			

Reviewing Engineer: *[Signature]*  
 Date Received: July 23, 2021  
 Date Reviewed: July 28, 2021  
 Jonathan Pera, P.E.  
 County Engineer

Page 8 of 8

CERTIFICATION OF AVAILABLE FUNDS

THIS IS TO CERTIFY THAT FUNDS ARE AVAILABLE AS FOLLOWS:

AMOUNT: \$964,683.40

APPROPRIATION: G-01-45-716-018-903- \$188,969.00  
G-01-45-716-019-903- \$613,559.00  
C-04-55-986-002-901- \$162,155.40

PURPOSE: Authorize an award of contract to New Prince  
Concrete Construction Company Inc. for the  
replacement of the Ratzer Road Culver No. 1600-367.



Richard Cahill, Director of Finance

DATED: August 10, 2021

# County of Passaic Board of County Commissioners

OFFICE OF COUNTY COMMISSIONERS

Director Pasquale "Pat" Lepore  
Deputy Director Bruce James  
Assad R. Akhter  
John W. Bartlett  
Theodore O. Best, Jr.  
Terry Duffy  
Cassandra "Sandi" Lazzara

401 Grand Street  
Paterson, New Jersey 07505

Tel: 973-881-4402  
Fax: 973-742-3746

Anthony J. De Nova III  
Administrator

Matthew P. Jordan, Esq.  
County Counsel

Louis E. Imhof, III, RMC  
Clerk Of The Board



## Public Meeting (Board Meeting)

Date: Aug 10, 2021 - 5:30 PM

Location: County Administration Building  
Webex - 220  
401 Grand Street  
Paterson, NJ 07505

Agenda: RESOLUTION AUTHORIZING AN AWARD OF CONTRACT TO MURRAY PAVING & CONCRETE, LLC FOR THE COURTHOUSE ANNEX DOOR AND REVERSE PROJECT IN THE CITY OF PATERSON, PURSUANT TO N.J.S.A. 40A:11-10 ET SEQ., ALL AS NOTED IN THE RESOLUTION.

THIS RESOLUTION WAS REQUESTED BY:

REVIEWED BY:

Anthony J. De Nova III  
COUNTY ADMINISTRATOR

APPROVED AS TO FORM AND LEGALITY:

Matthew P. Jordan, Esq.  
COUNTY COUNSEL

Public Works

COMMITTEE NAME

<b>Official Resolution#</b>	<b>R20210752</b>							
Meeting Date	08/10/2021							
Introduced Date	08/10/2021							
Adopted Date	08/10/2021							
Agenda Item	I-36							
CAF #	C-04-55-163-002-903							
Purchase Req. #								
Result	Adopted							
<b>COMMISSIONER</b>	<b>PRES.</b>	<b>ABS.</b>	<b>MOVE</b>	<b>SEC</b>	<b>AYE</b>	<b>NAY</b>	<b>ABST.</b>	<b>RECU.</b>
Lepore	✓				✓			
James	✓		✓		✓			
Akhter	✓			✓	✓			
Bartlett	✓				✓			
Best Jr.	✓				✓			
Duffy	✓				✓			
Lazzara	✓				✓			

PRES.= present ABS.= absent  
MOVE= moved SEC= seconded  
AYE= yes NAY= no ABST.= abstain  
RECU.= recuse

Dated: August 11, 2021

**RESOLUTION AUTHORIZING AN AWARD OF CONTRACT TO MURRAY PAVING & CONCRETE, LLC FOR THE COURTHOUSE ANNEX DOOR AND REVERSE PROJECT IN THE CITY OF PATERSON, PURSUANT TO N.J.S.A. 40A:11-10 ET SEQ.**

**WHEREAS**, the County of Passaic (hereafter “County”) is a government body incorporated pursuant to N.J.S.A. 40:18-1, et seq. and vested with all rights contained therein; and

**WHEREAS**, pursuant to N.J.S.A. 40:20-1, the Board of County Commissioners of the County of Passaic (hereafter “Board”) is vested with decision making powers on behalf of the County; and

**WHEREAS**, pursuant to N.J.S.A. 40A:11-10, et seq., the governing bodies of two or more contracting units may provide by joint agreement for the provision and performance of goods and services for use by their respective jurisdiction; and

**WHEREAS**, the County is a member of the Educational Services Commission of New Jersey, (hereafter “ESCNJ”), a joint cooperative pricing system offering competitive pricing for various goods and services, established pursuant to N.J.S.A. 40A:11-10, et seq.; and

**WHEREAS**, in compliance with the law, ESCNJ issued and awarded a contract to various vendors pursuant Contract No. #65MCFSCCPS (JOC Contract No. 20/21-03), which includes Murray Paving & Concrete, LLC; and

**WHEREAS**, the County Engineer received a quote for the courthouse annex door and reverse project in an amount not to exceed four thousand four hundred thirty-two dollars and forty-three cents (\$4,432.43), which is being recommended for approval; and

**WHEREAS**, funds are available in Account No. C-04-55-163-002-903 or any other account that may be deemed appropriate by the Chief Financial Officer or his designee, and the availability of funds has been contingently certified by the Chief Financial Officer subject to sufficient funds being appropriated by the Board in the 2021 and/or subsequent years’ County budget (s), which is attached to and made part of this Resolution; and

**WHEREAS**, this matter was discussed at a meeting on July 28, 2021 by the Public Works Committee and is being recommended to the Board for approval.

**NOW, THEREFORE, LET IT BE RESOLVED**, pursuant to N.J.S.A. 40A:11-10, et seq., that the Board of County Commissioners of the County of Passaic hereby authorizes an award of contract to Murray Paving & Concrete, LLC for the courthouse annex door and reverse project in an amount not to exceed four thousand four hundred thirty-two dollars and forty-three cents (\$4,432.43) as recommended by the County Engineer.

**LET IT BE FURTHER RESOLVED**, that the Purchasing Agent and all other necessary officers and employees be and hereby are authorized and directed to take such further actions and sign such documents as are necessary to effectuate the purpose of this Resolution, including but not limited to issuance of an appropriate Purchase Order.

NDA

August 10, 2021





Order

**ESCNJ State Approved Coop #65MCESCCPS**

**JOC Contract No.: 20/21-03**

**New Job Order**       **Modify an Existing Job Order**

Job Order Number: 093229.00

Job Order Title: Passaic County - Courthouse Annex Door & Reverse

Contact: Andrew Thompson

Contractor Name: Murray Paving and Concrete

Phone: 9737423936

Contact: Steven Ramos

Phone:

**Work to be Performed**

Work to be performed as per the Final Scope of Work and the Price Proposal dated 06/04/2021, and as per the terms and conditions of JOC Contract No 20/21-03.

Brief Task Order Description:

Reverse swing of existing door and reuse hardware.

**Time of Performance**

Estimated Start Date:

Estimated Completion Date:

**Liquidated Damages**

Will apply:

Will NOT apply:

**Validation Information**

*Normal Working Hours*

*0.9600*

Job Order Firm Fixed Price: \$4,432.43

Owner Purchase Order:

**Approvals**

Project Manager \_\_\_\_\_

Date

Bureau/Division Manager \_\_\_\_\_

Date

Technical/Engineer Review \_\_\_\_\_

Date

Contracting Officer \_\_\_\_\_

Date

Introduced on: August 10, 2021

Adopted on: August 10, 2021

Official Resolution#: R20210752



**Scope of Work**

**ESCNJ State Approved Coop #65MCECCPS**

---

**To:** Contractor Project Manager  
Murray Paving and Concrete  
210 South Newman Street  
Hackensack, NJ 07601

**From:** Andrew Thompson  
Passaic County  
No Address Input  
  
9737423936

**Job Order No:** 093229.00  
**Job Order Title:** Passaic County - Courthouse Annex Door & Reverse  
**Contract #:** 20/21-03

---

The following items detail the scope of work as discussed at the site. All requirements necessary to accomplish the items set forth below shall be considered part of this scope of work.

- Remove existing door leading to attic mechanical area and reverse the swing so that the panic device is exiting the stairwell. Reuse and reinstall hardware at new swing location.
- Remove and replace the existing lock exiting the courtroom with new, battery operated, mechanical keypad function lock.
- Procure and install new envelope slot covers at 2 locations as directed by Andrew Thompson.

Subject to the terms and conditions of JOC Contract 20/21-03.

\_\_\_\_\_  
Andrew Thompson

\_\_\_\_\_  
Date

\_\_\_\_\_  
Contractor Project Manager

\_\_\_\_\_  
Date

**Introduced on:** August 10, 2021  
**Adopted on:** August 10, 2021  
**Official Resolution#:** R20210752

### Contractor's Cost Proposal - Summary (L/E/M)

ESCNJ State Approved Coop #65MCESCCPS

Date: June 11, 2021

Re: IQC Master Contract #: 20/21-03  
 JOG Work Order #: 093229.00  
 Owner PO #:  
 Title: Passaic County - Courthouse Annex Door & Reverse  
 Contractor: Murray Paving and Concrete  
 Proposal Value: \$4,432.43

<b>Section - 01</b>	<b>\$2,398.01</b>
<b>Section - 08</b>	<b>\$2,034.42</b>
<b>Proposal Total</b>	<b>\$4,432.43</b>

This Proposal total represents the correct total for the proposal. Any discrepancy between line totals, sub-totals and the proposal total is due to rounding of the line totals and sub-totals.

The Percentage of NPP on this Proposal: %

**Contractor's Cost Proposal - Detail (L/E/M)**

**ESCNJ State Approved Coop #65MCECCPS**

Date: June 11, 2021  
 Re: IQC Master Contract #: 20/21-03  
 JOC Work Order #: 093229.00  
 Owner PO #:  
 Title: Passaic County - Courthouse Annex Door & Reverse  
 Contractor: Murray Paving and Concrete  
 Proposal Value: \$4,432.49

Sect.	Item	Mod.	UOM	Description	Line Total
Labor	Equip.	Material	(Excludes)		
<b>Section - 01</b>					
1	01 22 10 00 0002		EA	Reimbursable Fees Reimbursable Fees will be paid to the contractor for eligible costs. Insert the appropriate quantity to adjust the base cost to the actual Reimbursable Fee. If there are multiple Reimbursable Fees, list each one separately and add a comment in the "note" block to identify the Reimbursable Fee (e.g. sidewalk closure, road cut, various permits, extended warranty, expedited shipping costs, etc.). A copy of each receipt shall be submitted with the Price Proposal.	\$96.00
			Installation	Quantity 100.00 x Unit Price 1.00 x Factor 0.9600 = Total 96.00	
ALLOWANCE FOR ENVELOPE SLOT COVERS FOR EXISTING DOORS					
2	01 22 20 00 0008		HR	Carpenter For tasks not included in the Task Catalog and as directed by owner only.	\$779.37
			Installation	Quantity 8.00 x Unit Price 101.48 x Factor 0.9600 = Total 779.37	
REMOVE EXISTING DOOR, REMOVE EXISTING HARDWARE, REVERSE SWING OF EXISTING DOOR ON EXISTING WOOD FRAME, CHISEL HINGES OUT, CHISEL LATCH SET OUT, REINSTALL HARWARE SO PANIC BAR LEADS FROM THE STAIRWELL TO THE 2ND FLOOR LEVEL, INSTALL NEW ENVELOPE SLOT COVERS (2) AS DEPICTED BY ANDREW THOMPSON					
3	01 22 20 00 0006 0002		MOD	For Foreman, Add	\$38.94
			Installation	Quantity 8.00 x Unit Price 5.07 x Factor 0.9600 = Total 38.84	
4	01 22 20 00 0016		HR	Laborer For tasks not included in the Task Catalog and as directed by owner only.	\$715.70
			Installation	Quantity 8.00 x Unit Price 89.19 x Factor 0.9600 = Total 715.70	
REMOVE EXISTING DOOR, REMOVE EXISTING HARDWARE, REVERSE SWING OF EXISTING DOOR ON EXISTING WOOD FRAME, CHISEL HINGES OUT, CHISEL LATCH SET OUT, REINSTALL HARWARE SO PANIC BAR LEADS FROM THE STAIRWELL TO THE 2ND FLOOR LEVEL, INSTALL NEW ENVELOPE SLOT COVERS (2) AS DEPICTED BY ANDREW THOMPSON					
5	01 22 20 00 0057		HR	Project Manager	\$768.00
			Installation	Quantity 4.00 x Unit Price 200.00 x Factor 0.9600 = Total 768.00	
VALUE ENGINEER DESIGN WITH COUNTY TEAM FOR LOCK DEVICE EXITING THE COURTROOM AREA TO A BATTERY OPERATED CORBIN RUSWIN MECHANICAL LOCK AND LEVER TRIM, PROCURE NEW ENVELOPE SLOT COVERS - FIELD DIMENSIONS - BRASS TO MATCH					
<b>Subtotal for Section - 01</b>					<b>\$2,398.01</b>
<b>Section - 08</b>					

Introduced on: August 10, 2021  
 Adopted on: August 10, 2021  
 Official Resolution #: R20210752  
 Official Contractor's Cost Proposal Detail (L/E/M) Report

Contractor's Cost Proposal - Detail (L/E/M) Continues..

Job Order No: 093229.00  
 Job Order Title: Passaic County - Courthouse Annex Door & Reverse

Section - 08

6	08	71	11	00.2248	EA	Classroom F42 Pre-Assembled Lockset (Corbin Russwin UT5255)Locked with key outside. inside always unlocked.				\$1,265.87
						Quantity	Unit Price	Factor	Total	
					Installation	1.00 x	1,262.94 x	0.9600 =	1,241.22	
					Demolition	1.00 x	25.67 x	0.9600 =	24.64	
						HARDWARE EXITING COURTROOM REPLACEMENT LEVER				
7	08	71	11	00.2280	EA	Five Button, Mortise Locking Device With Deadbolt, Passage And Lockout, Mechanical Pushbutton Combination Lock With Key Override, Lever (Kaba® Simplex® 8100 Series)				\$768.55
						Quantity	Unit Price	Factor	Total	
					Installation	1.00 x	736.14 x	0.9600 =	706.69	
					Demolition	1.00 x	64.43 x	0.9600 =	61.85	
						HARDWARE EXITING COURTROOM MECHANICAL INSTALL, PROGRAMMING, TRAINING				

Subtotal for Section - 08 \$2,034.42

Proposal Total \$4,432.43

This Proposal total represents the correct total for the proposal. Any discrepancy between line totals, sub-totals and the proposal total is due to rounding of the line totals and sub-totals.

The Percentage of NPP on this Proposal: %

CERTIFICATION OF AVAILABLE FUNDS

THIS IS TO CERTIFY THAT FUNDS ARE AVAILABLE AS FOLLOWS:

AMOUNT: \$4,432.43

APPROPRIATION: C-04-55-163-002-903

PURPOSE: Authorizing an award of contract to Murray Paving & Concrete, LLC for the Courthouse Annex Door and Reverse Project.



Richard Cahill, Director of Finance

DATED: August 10, 2021

# County of Passaic Board of County Commissioners

OFFICE OF COUNTY COMMISSIONERS

Director Pasquale "Pat" Lepore  
Deputy Director Bruce James  
Assad R. Akhter  
John W. Bartlett  
Theodore O. Best, Jr.  
Terry Duffy  
Cassandra "Sandi" Lazzara

401 Grand Street  
Paterson, New Jersey 07505

Tel: 973-881-4402  
Fax: 973-742-3746

Anthony J. De Nova III  
Administrator

Matthew P. Jordan, Esq.  
County Counsel

Louis E. Imhof, III, RMC  
Clerk Of The Board



## Public Meeting (Board Meeting)

Date: Aug 10, 2021 - 5:30 PM

Location: County Administration Building  
Webex - 220  
401 Grand Street  
Paterson, NJ 07505

Agenda: RESOLUTION AUTHORIZING AN AWARD OF CONTRACT TO KS ENGINEERS, P.C. FOR THE ENGINEERING DESIGN SERVICES FOR THE REPLACEMENT OF THE OTTERHOLE ROAD CULVERT NO. 1600-148 OVER POST BROOK IN THE TOWNSHIP OF WEST MILFORD, PURSUANT TO N.J.S.A. 40A:11-5, ET SEQ., ALL AS NOTED IN THE RESOLUTION.

THIS RESOLUTION WAS REQUESTED BY:

REVIEWED BY:

Anthony J. De Nova III  
COUNTY ADMINISTRATOR

APPROVED AS TO FORM AND LEGALITY:

Matthew P. Jordan, Esq.  
COUNTY COUNSEL

Public Works

COMMITTEE NAME

<b>Official Resolution#</b>	<b>R20210753</b>							
Meeting Date	08/10/2021							
Introduced Date	08/10/2021							
Adopted Date	08/10/2021							
Agenda Item	I-37							
CAF #	C-04-55-166-002-920							
Purchase Req. #								
Result	Adopted							
<b>COMMISSIONER</b>	<b>PRES.</b>	<b>ABS.</b>	<b>MOVE</b>	<b>SEC</b>	<b>AYE</b>	<b>NAY</b>	<b>ABST.</b>	<b>RECU.</b>
Lepore	✓				✓			
James	✓		✓		✓			
Akhter	✓			✓	✓			
Bartlett	✓				✓			
Best Jr.	✓				✓			
Duffy	✓				✓			
Lazzara	✓				✓			

PRES.= present ABS.= absent  
MOVE= moved SEC= seconded  
AYE= yes NAY= no ABST.= abstain  
RECU.= recuse

Dated: August 11, 2021

**RESOLUTION AUTHORIZING AN AWARD OF CONTRACT TO KS ENGINEERS, P.C. FOR THE ENGINEERING DESIGN SERVICES FOR THE REPLACEMENT OF THE OTTERHOLE ROAD CULVERT NO. 1600-148 OVER POST BROOK IN THE TOWNSHIP OF WEST MILFORD, PURSUANT TO N.J.S.A. 40A:11-5, ET SEQ.**

**WHEREAS**, the County of Passaic (hereafter "County") will undertake a project for the Replacement of the Otterhole Road Culvert No. 1600-148 over Post Brook in the Township of West Milford (hereafter "Project"); and

**WHEREAS**, pursuant to N.J.S.A. 40A:11-5, et seq. the County issued RFQ-21-009 seeking qualifications for a pool of engineers, architects, land surveyors, planners, landscape architects, and environmental health and safety engineers for calendar year 2021, to be hired on an as-needed basis, to provide professional services to the County; and

**WHEREAS**, pursuant to N.J.S.A. 19:44A-20.4, the County's request for qualifications is a fair and open process, specifically, the qualification for the pool of engineers, architects, land surveyors, planners, landscape architects, and environmental health and safety engineers for calendar year 2021 is publicly advertised, awarded under a process that provides for public solicitation of qualifications, established the basis of an award and disclosure process documented in writing prior to any solicitation, and is publicly opened and announced when awarded; and

**WHEREAS**, on December 8, 2020 the Board of County Commissioners of the County of Passaic (hereafter "Board") passed Resolution No. R20201102 qualifying a pool of engineers, architects, land surveyors, planners, landscape architects, and environmental health and safety engineers for calendar year 2021, as recommended by the Passaic County Engineer, to be hired on an as-needed basis, which included KS Engineers, P.C.; and

**WHEREAS**, the County Engineer is recommending an award of contract to KS Engineers, P.C., for the Engineering Design Services for the Replacement of the Otterhole Road Culvert No. 1600-148 over Post Brook in the Township of West Milford, in an amount not to exceed one hundred eighty-nine thousand seven hundred seventy-eight dollars and sixty-two cents (\$189,778.62) as per the proposal attached hereto and made part of this Resolution; and

**WHEREAS**, funds are available in Account No. C-04-55-166-002-920 or any other account that may be deemed appropriate by the Chief Financial Officer or his designee, and the availability of funds has been contingently certified by the Chief Financial Officer subject to sufficient funds being appropriated by the Board in the 2021 and/or subsequent years' County budget (s), which is attached to and made part of this Resolution; and

**WHEREAS**, this matter was discussed on July 28, 2021, by the Public Works Committee and is being recommended to the Board for approval.

**NOW, THEREFORE, LET IT BE RESOLVED**, pursuant to N.J.S.A 40A:11-5(1)(a)(i), that the Board of County Commissioners of the County of Passaic hereby authorizes the award of contract to KS Engineers, P.C., for the Engineering Design Services for the Replacement of the Otterhole Road Culvert No. 1600-148 over Post Brook in the Township of West Milford, in an amount not to exceed one hundred eighty-nine thousand seven hundred seventy-eight dollars and sixty-two cents (\$189,778.62), as recommend by the Passaic County Engineer.

**LET IT BE FURTHER RESOLVED**, the Clerk of the Board shall print, in the official newspaper, a brief notice stating the nature, duration, service, and amount of the contract to KS Engineers, P.C. and maintain a copy of the resolution on file and available for public inspection in the Office of the Clerk of the Board.

**LET IT BE FURTHER RESOLVED**, that the Clerk of the Board, County Counsel, and Director of the Board of County Commissioners are authorized to execute the contract and take any other steps necessary to carry out the purpose of this resolution.

NDA

August 10, 2021



**SCOPE OF SERVICES****A. Structural Inspection**

1. A field investigation shall be conducted at the beginning of the Project to ascertain the existing conditions of the structures. The field Team Leader for the inspection shall be a New Jersey License Professional Engineer. Existing widening plans from 1938 are available for Bridge No. 1600-148 formerly known as Carmentown Road. The Bridge Evaluation Report Cycle No. 1, dated October 16, 2012 prepared by TransSystems is available for review. The Consultant shall submit an inspection summary letter for the structure.
2. Consultant to take and label photographs of the entire structure, surrounding properties, and project limits to establish a photographic record of the project area during the design phase of the project. The Consultant to submit two CDs of those photographs (with a labeling system).
3. The structural inspection may be a factor in determining the demolition/staging limits.

**B. Field Survey**

1. The Team Leader for the field survey work shall be a New Jersey Licensed Professional Land Surveyor. The fieldwork shall include a ground survey in sufficient scope to accomplish this project. The Consultant is required to arrange and provide any necessary traffic control, including, but not limited to, traffic directors – flaggers, and police traffic control, which shall be in accordance with the Manual on Uniform Traffic Control Device (MUTCD) and County and Municipal Police. All costs associated with traffic control, including police traffic control is to be included in the consultant's cost proposal.
2. Provide for all and any survey work as may be required. Survey traverse and level runs shall originate and terminate on Control Monuments and Benchmarks that have been established by an approved agency.
3. Horizontal control shall be tied to the NAD 83 New Jersey Plane Coordinate System.
4. Vertical control shall be tied to North American Vertical Datum – NAVD 1988. Please note, NJDEP permit drawings may require to be converted to the National Geodetic Vertical Datum (NGVD) and/or provide the conversion equation between the two vertical datums.
5. Establish control points as necessary to reference the project baseline
6. Topography shall be 1-foot contour intervals.
7. Establishment of Project / Bridge Center Line (CL). Project CL should be ROW CL, when possible. Project CL will be Bridge CL. Project CL shall be tied to ROW through station/offsets.
8. Base mapping will be prepared to depict existing site conditions, limits of work, and means of access. Field survey will be performed detailing planimetric features and right-of-way pertinent to the preparation of base mapping and right-of-way plans for the proposed project. The base mapping shall also extend 60' from the edge of the roadway on both sides of Otterhole Road.
9. Consultant to perform a survey of existing features, including existing roadway elements, utility poles, drainage structures, guide rail, fences, signs, and limits of wooded areas. Individual trees and specimen shrubs are to be located within easement and taking parcel areas, and within the entire project survey area (including 50' from the edge of the roadway). Provide additional elevation details to the variation of the pavement at the curb line for drainage purposes.
10. Station and offset from centerline to existing drainage structures will be shown on the plan. Type of structure, type of casting, size and types of pipes entering the structure, inlet grating elevation and inverts on accessible pipes will be recovered by field survey.

Introduced on: August 10, 2021  
Adopted on: August 10, 2021

Official Resolution#: R20210753

11. Roadway cross-sections shall be taken at 50' intervals at a width suitable for design. Cross sections shall be provided at a minimum of 400' on the north and south approach; and 50' from the edge of existing pavement on each side of the roadway. Additional cross section shall be taken at 20' intervals adjacent to each side of the bridge within 100 feet of the bridge. A separate cross section is to be taken at each driveway. Roadway cross sections shall be taken at 50' intervals along the side streets.
12. Driveway profiles are to be taken from the centerline extending 75' up the driveway. Spot grades are to be taken to establish the centerline profile of the driveways.
13. The project baseline is to be established in the field by placement of PKs at every 50 feet along the existing roadway. Ties are to be established at the beginning and ending station, and PI of each curve. The project baselines are to be established along the physical centerline alignment or at the centerline of the right-of-way after positions are ascertained.
14. The existing bridge is to be detailed and measured as required for development of permit documents and for demolition and construction plan purposes.
15. The existing water openings at the bridge shall be measured for flood hazard area purposes and for demolition plan purposes.
16. For the hydraulic analysis, at a minimum, additional stream cross sections are to be taken at 100' intervals for a distance of 500' upstream and downstream, 25' intervals for the first 100', and at the upstream and downstream faces of the bridge, and as necessary to develop the hydraulic model.
17. Wetland area limits are to be located and mapped as delineated.
18. In performing the survey work, horizontal and vertical baseline control points will be established in the field for Contractor's reference during construction. One permanent benchmark will be established on each side of the bridge.
19. The geotechnical boring locations shall be field recover by the Consultant's surveyor.

#### C. Utility Engineering

1. Determine the location (horizontal and vertical) of all utility facilities within the project limits. Utility mark-outs shall be made through coordination with the individual utility companies. Utility locations, as field markup by the utility companies, are to be recovered by survey and shown on the plans.
2. The Consultant shall contact ALL utility companies that may be affected by the construction to verify current or future facilities at the project site. Prepare utility verification plan and conflict identification plan for each utility and send to the utility owners. The Consultant shall request if the utility has any proposed future utility plan for the project area.
3. The County requires the Consultant to coordinate and attend at least two (2) utility meetings with all involved utility companies prior to finalizing the project. If available, the County will attend the field meeting. Consultant to coordinate with utility to determine any potential issues and if temporary / permanent relocation(s) is required. The Consultant to prepare and submit meeting minutes of the field meeting(s) to all utilities and the County.
4. Consultant to prepare a separate utility relocation plan for the affected utilities. Consultant to coordinate with each affected utilities and show the locations of the proposed relocations on the utility relocation plan. The Consultant to submit the utility relocation plan to the affected utilities for their concurrence. The utility relocation plan to be included in the Contract Plans, upon receipt of written acceptance / concurrence from the utility company.

Introduced on: August 10, 2021

Adopted on: August 10, 2021

Official Resolution#: R20210753

5. The Consultant shall notify each utility in writing when the Contract Plans are finalized and when the project is advertised for construction and provide each utility owner with a copy of the final utility relocation plan. The plans and specifications shall describe in detail the responsibility of the contractor and the utility companies.
6. All copies of correspondence between the Consultant and each utility shall be submitted to the County Engineer in a timely manner. The consultant shall have the utility companies commitment in writing.
7. Consultant to contact the local / regional school to determine if any school bus routes will be affected by the project.
8. Consultant to contact NJ Transit to determine if any NJ Transit bus lines or any other bus lines would be affected by the project.
9. No test pits are anticipated during the design phase.

**D. Geotechnical Engineering**

1. Collect and review any existing geotechnical data. The County has no site-specific geotechnical data.
2. Proposed soil boring locations shall be approved by the County prior to the start of work. Adequate number of soil boring logs (minimum of two (2) for each substructure element) shall be taken and used to determine the type of foundations required. The County's On-Call Testing geotechnical consultant will perform the actual drilling for the soil borings, perform the laboratory tests of the soil samples and provide the boring logs to the Design Consultant. Design Consultant to advise if any soil testing is required.
  - A. The Design Consultant shall perform the following tasks:
    1. Proposed the quantity and locations of the soil borings.
    2. Provide a full time representative to be in the field to inspect the boring operations.
    3. As drilled boring locations shall be recovered by the Consultant's field survey. Boring locations are to be shown on the Contract Plans.
    4. Perform the required geotechnical analysis based on the boring logs and any test results.
    5. Prepare a formal geotechnical investigation report, including the suggested type of foundation work and the depth of the coarse aggregate layers under the bridge foundations. Final concurrence shall be obtained from the County Engineer in writing prior to proceeding with any design work. The Geotechnical Investigation Report to be included in the bid documents and the boring logs shall be incorporated in the plans.
  - B. All costs associated with the County's On-Call Testing geotechnical consultant is under a separate contract.

**E. Right-of-Way**

1. Existing right-of-way and property lines are to be determined through deed and map research and field surveys of existing evidence. Front property corners will be located along the adjacent roadways extending 500 feet beyond the beginning and end of the project.
2. The Consultant will determine if any additional ROW and/or Easements (temporary or permanent) are required due to the Project work. If ROW and/or Easements are required, the Consultant is to prepare all the necessary documentation (metes and bounds description, General Parcel Property Maps, and Individual Parcel Map).
3. Alignment Maps and General Property Parcel Maps, if required, are to be prepared in accordance with the New Jersey Department of Transportation (NJDOT) "Manual for the Preparation of Right-of-Way Maps and Agreements" and in accordance with the Passaic County's Standards. Consultant shall provide all necessary information and documents (maps, descriptions, etc.) to the County to secure the necessary

Introduced on: August 10, 2021  
Adopted on: August 10, 2021  
Official Resolution#: R20210753

easements (permanent or temporary) and/or right-of-way takings for the project.

4. The Consultant shall include all costs associated with permanent and/or temporary easements and / or right of way takings for up to four (4) properties in the proposal.

**F. \*\* Permits \*\* (See Also Amendments Below)**

1. Obtain the necessary design and construction approvals from all agencies having jurisdiction (i.e. New Jersey Department of Environmental Protection (NJDEP), Hudson-Essex-Passaic Soil Conservation District (HEPSCD), Historic Preservation Office (HPO), Highlands, Green Acres, etc.) under design phase. Consultant shall be responsible to confirm all necessary permit and construction approvals required for the project.
2. NJDEP -- Freshwater Wetlands and Flood Hazard Area Permits
  - a. Shall include all work as required to provide NJDEP will complete application package(s) including, but not limited to all studies, reports and plans in compliance with NJDEP regulations.
  - b. A Pre-Application meeting shall be required. Consultant shall coordinate a meeting with County prior to scheduling the Pre-Application meeting. Consultant to coordinate NJDEP Pre-Application Meeting. County may attend Pre-Application Meeting, if available.
  - c. Shall incorporate all surface water quality standards.
  - d. The consultant is required to complete all hydrologic and hydraulic analysis as required for Flood Hazard Area Permits for the replacement structure.
  - e. The consultant to include the relocation of any underground utility and drainage within the permit documentation.
  - f. Investigate presence of threatened and endangered species.
  - g. Consultant to submit a full draft copy of the permit application to the County at the time the LURP2 form is requested to be signed by the County (i.e. prior to submission to NJDEP).
  - h. County signs the application as owner, applicant.
  - i. Consultant to submit to NJDEP and the County a CD of all the submitted permit plans and supporting documents (PDF format).
  - j. County reimburses all permit review fees as out of contract, out of pocket expenses.
3. Soil Erosion and Sediment Control Plan Certification
  - a. Shall include all work as required to provide HEPSCD will complete application package(s) including, but not limited to all studies, reports and plans in compliance with HEPSCD regulations.
  - b. County signs the application as owner, applicant.
  - c. Consultant to submit to HEPSCD and the County a copy of all of the submitted permit plans and supporting documents.
  - d. County reimburses all permit review fees as out of contract, out of pocket expenses.
4. Historic Preservation Office (HPO)
  - a. Upon County approval of the preferred structure type and bridge width, the Consultant is to submit to HPO (minimum 30 days prior to NJDEP permit submission) the following package for their review to determine if a Phase 1A cultural resources study is required:
    1. Transmittal letter with description of project
    2. Project Location Map (Road Map and USGS)
    3. Proposed Plan
    4. Proposed Profile
    5. Existing General Plan, Elevation and Section
    6. Proposed General Plan, Elevation and Section
    7. Aerial of project site and surrounding areas
    8. Eight to ten color photographs of project site and photo location map
5. Highlands Permit
  - a. The project site is located in the Highlands Preservation Area. Consultant to prepare for and obtain any required Highlands permit and/or exemption request.
6. Green Acres

a. Green Acres is not anticipated for this project. However, Consultant is to confirm.

7. Waterfront Development Permit

a. Waterfront Development Permit is not anticipated for this project.

8. Coast Guard

a. Coast Guard Permit is not anticipated for this project.

**G. Cost Estimate**

1. Prepare an Engineer's Estimate of Construction Cost estimate upon the completion of each phase. Two sets of the calculations used to derive the Estimate of Quantities shall be submitted to the County with the final plans.
2. Two (2) sets of properly signed and sealed Engineer's Estimate shall be furnished to the County Engineer. Additionally, two (2) sets and a digital MS-Excel copy of the Engineer's Estimate shall be furnished to the County Engineer for County review prior to submittal of final documents.

**H. Construction Contract Documents**

1. A start-up meeting will be scheduled with the engineering staff of Passaic County to review and discuss the scope of work. Progress meetings will be held with the County for project status updates and discussion of issues to be expedited. A minimum of four (4) progress meetings are anticipated. The Consultant shall attend one (1) public presentation meeting. The County Engineer shall determine the date for the progress meetings and public presentation meeting. The Consultant is to prepare and distribute the meeting(s) minutes.
2. The superstructure replacement options are to be discussed during the start-up meeting. Three (3) to four (4) superstructure replacement options will be evaluated for feasibility of construction for the bridge. The options include, but not limited to, precast concrete arch/frame, precast concrete box culvert, precast concrete slab beams, steel stringers, etc. A concrete riding surface over the bridge (in lieu of asphalt) is to be considered for this project. The Consultant is to determine the advantages and disadvantages of each option and provide in Superstructure Alternative Analysis Report.

The Consultant is to consider constructability, environmental/permit concerns, construction staging, profile, superstructure depth, loading, design flexibility, minimizing right-of-way takings or easements, utility coordination, construction costs, and any other pertinent conditions. The Consultant is to prepare and submit to the County a summary report of his superstructure alternatives analysis Report. The summary report is to state the preferred superstructure alternative for the County review and approval. County approval of superstructure alternative is required prior to the Consultant completing the permit drawings and final design.

3. Based on the geotechnical investigation, the Consultant is to evaluate the various substructure alternatives. The Consultant is to provide a substructure recommendation (spread footings, piles, etc.) to the County Engineer for review and approval, prior to final design. Seismic loading shall be included in the design of the substructures.
4. The bridge wingwalls are anticipated to be cast-in-place concrete, unless otherwise directed by the County Engineer.
5. Various bridge width alternatives are to be investigated. The roadway width of the proposed bridge(s) shall be as per NJDOT and/or Federal Highway design criteria (AASHTO), including traffic counts, characteristics, volumes, compositions and speeds, unless otherwise approved by the County.
6. The consultant is to perform traffic counts at the bridge. The traffic counts are to be performed for an entire week. The consultant is to determine the average daily traffic. Consultant to request accident data

from the local municipality police department for a minimum of the last 3 years period, Consultant to review accident data to determine possible adjustments to the project.

Official Resolution#: R20210753

7. Various bridge railing/pylon designs are to be presented for selection as appropriate for the project location and setting. Stone facing (vener or form liner) options for the wingwalls, headwalls, and parapet / pylon are to be considered as part of the design of the project.
8. All the substructures are anticipated to be removed and replaced.
9. The project is anticipated to be constructed in one stage with a signed Detour Route. The Consultant is to prepare the necessary traffic signage and striping plan for County approval. The Consultant shall provide all the necessary details, layouts, barriers, signage, and striping on the Plans and in the specifications. All proposed elements to be compliant with MUTCD and NJDOT guidelines for maintenance and protection of traffic. Traffic Control Plan to be submitted to the County for approval. Upon County approval, Consultant to submit the Traffic Control Plan to the West Milford Township Police Department and West Milford Engineering Department for review.
10. Consultant to determine the feasibility of providing a pedestrian access thru the project site during construction. Consultant to provide pedestrian access in Contract documents (which may include a temporary bridge), if ultimately required for the project.
11. The consultant is to determine the maximum allowed hydraulic opening of the proposed bridge that will meet the NJDEP Flood Hazard Area permit.
12. The County Engineer will approve the bridge superstructure/substructure type prior to preparing NJDEP applications and proceeding with the design.
13. Consultant shall prepare steel reinforcement bar tables for the cast-in-place concrete elements and include them in the plans.
14. The Consultant is to determine if driving sheeting is feasible at this project site. If feasible, the Contract plans shall include new left-in-place steel sheeting along the abutments and wingwalls. The Consultant is to determine the depth of sheeting required to provide proper scour protection (scour analysis to be performed by Consultant).
15. Project to be designed to be compliant with ADA standards and with NJDOT Complete Streets program.
16. Drainage is to be incorporated into the design, where appropriate.
17. Bridge lighting is not anticipated for this project.
18. Consultant shall provide a separate striping plan. All proposed elements to be compliant with MUTCD and NJDOT guidelines for Traffic Control. Proposed striping shown in bold, labeled with lane dimensions, taper lengths, and stripe width and color. Proposed signs shown in bold, labeled with MUTCD designation and offsets from plan elements. As this is a municipal roadway, the striping plan is to be submitted to the West Milford engineering department for review and comment. If West Milford concurs, RPMs are to be installed within the project area.
19. Consultant shall prepare mounted presentation boards (including color renderings) and other documents for one (1) public information meeting. The Consultant shall send a representative to the public information meeting to discuss the project and provide minutes to the meeting.
20. Consultant shall prepare final plans and specifications based upon the design criteria.
21. The County will be utilizing NJDOT funding for the construction of this project. Consultant shall prepare the three hard copies of plans, specifications, estimate, EO215, and other documentation will be submitted to NJDOT for their review and approval. NJDOT also requires an electronic PDF copy of the

Introduced on August 20, 2021  
Adopted by Board of Township of West Milford  
Official Resolution#: R20210753

submissions. Consultant shall address NJDOT comments. NJDOT may require electronic signature / seal of the drawings.

22. Upon obtaining all necessary construction permits, the bridge design will commence and will result in completed construction documents. Submission of the documents will be made at the 30% (concept), 60%, 90%, and 100% levels of completion for review and comments the County. The Consultant to provide one hard copy (1 full size sets) and one PDF copy of each submission document, per submission. Plans, supplemental specifications and design calculations will be submitted for review and comment prior to final submission. After incorporating the review comments in the plans, final submissions will be made.

23. Final Structure Design Plans:

- a. All plans will be prepared on 24 x 36 drafting film. Two (2) sets of properly signed and sealed final plan sets along with one (1) set of Mylars, archival quality Mylar and ink plans, shall be furnished to the County Engineer.
- b. Two (2) CD ROM discs of all final documents in both PDF and native file formats, including CADD drawing files compatible with AutoCAD (Consultant shall also supply appropriate drawing pen tables and fonts), Supplemental Technical Specifications, Estimate of Quantities, and Engineer's Estimate shall be furnished to the County Engineer. The Consultant shall follow NJDOT CADD Standards Manual. The minimum text height shall be 0.125. Additionally, the Consultant shall provide electronic coordinate point files for the project. This file shall include Point Number, N, E, Elevation, descriptions for all ROW / Easement points, Project CL points, Traverse Points, Base Points, Bridge Working points, and all other related project points required for layout.

24. Estimate of Quantities Supplemental Technical Specifications:

- a. Final Estimate of Quantities shall be included on the Plans as well as in the Bid Proposal. Two (2) sets and one (1) PDF of all calculations used to derive the Estimate of Quantities shall be presented to the County Engineer.
- b. Two (2) sets and a digital MS-Excel copy of the Engineer's Estimate shall be furnished to the County Engineer for County review at the 60%, 90% and 100% progress level submissions prior to submittal of final documents. For the final documents, two (2) sets of properly signed and sealed Engineer's Estimates shall be furnished to the County Engineer.
- c. The Consultant will include Supplemental Technical Specifications to the NJDOT Standard Specifications for Road and Bridge Construction (2019 Edition with amendments and modifications) and the County's Standard Specifications for the bridge project. Two (2) copies of the Specifications shall be furnished to the County Engineer for County review at the 90% and 100% progress level submissions prior to submittal of final documents. Two (2) sets of properly signed and sealed Technical Specifications shall be furnished to the County Engineer.
- d. For the bid documents, the Consultant to prepare a single PDF of the entire front end specifications, technical specifications, and the signed plans.

25. Project Design Reports:

- a. Prepare and provide to the County an Engineering Report containing all structural calculations and Scour Protection calculations.
- b. Prepare and provide to the County a Design Exception Report, if required. Consultant to notify the County in writing by the 60% design level if the project will require any design exception.
- c. Prepare and provide to the County an Engineer's Certification and a QA/QC Certification.

**L. Bidding Process & Award of Contract**

Assist the County during the bidding a, review of bids, assisting in responding to RFI's and/or questions during the bidding period, perform bid analysis, and make a recommendation of an award of contract. Consultant shall re-notify the utilities during the bidding phase.

**J. Construction Consultation and Inspection Services**

1. Consultant to attend the pre-construction meeting and prepare meeting minutes of construction meeting.
2. Consultant to attend utility meeting with the utilities, contractor, and County. Consultant to prepare utility meeting minutes.
3. The Consultant shall include the cost of review and approval of all shop drawings and working drawings, as received from the Contractor or their representatives, after the award of construction contracts.
4. The Consultant shall include the cost of reviewing and addressing any Contractor's Request for Information (RFI) during the construction phase.
5. Provide consultation and periodic inspection services (approximate 3 site visits) during the construction phase as required by the County Engineer.
6. Perform a final inspection of the structure at the completion of the Contractor's work and file a Report with the County Engineer.

**Design Criteria**

All work performed on this structure shall conform to the following standards and specifications.

1. Standard Specifications for Highway Bridges-AASHTO, latest edition
2. Standard Specification for Roadways –AASHTO, latest edition.
3. N.J.D.O.T. Design Manual Bridges and Structures, latest edition
4. N.J.D.O.T. Design Manual Roadways, latest edition.
5. N.J.D.O.T. Standard Specifications for Road and Bridge Construction
6. Any and all Standards of any Agency having jurisdiction on this project.
7. Plans shall be prepared in accordance with standard engineering practices and shall include:
  - a. Title Sheet, Key Map, Index of Sheets, etc.
  - b. Estimate of Quantities
  - c. Existing Plan, Elevation, and Section
  - d. Proposed Plan, Elevation, and Section
  - e. Typical Sections
  - f. Construction Plans,
  - g. Profiles (Existing as-built profile with elevations and proposed profile elevations)
  - h. Cross Sections
  - i. Tie, Horizontal and Vertical Control Sheet
  - j. Maintenance and Protection of Traffic
  - k. Construction Details
  - l. Structural Plans and Details
  - m. Reinforcement Bar Table
  - n. Utility Relocation Plan
  - o. Soil Borings Location and Boring Log Profiles
  - p. NJDEP Permits
  - q. Include copy of 1934 Proposed Bridge Extension Plan as a Reference Drawing

Introduced on: August 10, 2021

Adopted on: August 10, 2021

Official Resolution#: R20210753

SECTION 1 – SCOPE OF SERVICES

Page 8 of 12

**KSE**



8. Preparation of Supplemental Specifications that modify standard items or are additional non-standard items, shall conform and follow the format (including paragraph numbering) as in the NJDOT Standard Specifications for Road and Bridge Construction, 2019 edition as amended.

### **DRAWINGS SPECIFICATIONS AND REPORTS**

The Consultant shall provide and pay for all copies of Plans, Specifications and Reports used for reviews and approvals.

Passaic County will be responsible for only the reproduction costs required for bidding process and award of contract. The Consultant shall furnish to the County, one (1) complete set of reproducible Plans (mylars) and Specifications.

The following shall be included with Final Plan submission:

1. Two sets of the Design and Quantity Calculations
2. Two Copies of the Engineer's Estimated Cost
3. Disk with all project CADD drawings, PDF of Signed Plans, Specifications, and photographs.

### **Additional / Extra Work:**

If, during any part of the Project, it becomes apparent that additional work by the Consultant is needed, the following procedures shall apply:

1. The Consultant must notify the County Engineer in writing, as soon as it is evident that additional or extra work may be necessary.
2. The Consultant must submit a proposal to the County Engineer for all additional / extra work and that no work shall be done until Contract Modifications area executed.
3. The County will only reimburse for work that has been specifically authorized by Agreement (s) or Contract Modifications.
4. The Consultant shall not be paid for any work which exceeds the Contract ceilings as set forth in Agreement(s) or Contract Modifications.

### **AMENDMENTS TO THE ABOVE SCOPE OF WORK:**

#### **Task F, Permits**

#### **Task 3: NJDEP Freshwater Wetlands General Permit #10A Application**

This proposal assumes that the proposed project will impact freshwater wetlands and State open waters located adjacent to the roadway and bridge. Therefore, KSE will prepare an application for a General Permit #10A (GP #10A – Very Minor Road Crossings) in accordance with the *Freshwater Wetlands Protection Act Rules* at NJAC 7:7A and make an online submission to the NJDEP Division of Land Resource Protection (Division). The submission will include required forms, figures, maps, photographs, wetland delineation summary and documentation, proof of public notice, compliance statement, Natural Heritage Program Letter, and permit drawings. GP#10A limits the amount of allowable wetland disturbance to ¼ acre (10,890 sf) for a short crossing scenario and 1/8 acre (5,445 sf) for a long crossing scenario. It is assumed that the project can remain under these allowable limits. If the scope of the project exceeds any of the regulatory requirements of GP#10A and an Individual Permit is required, associated efforts will be considered extra services. Additionally, mitigation is required for all permanent loss and/or disturbance of 0.1 acre or greater of freshwater wetlands or State open waters under GP#10A. This proposal assumes that the project will not equal or exceed 0.1 acre of permanent wetland/State open water loss and that mitigation will not be required. Tasks and efforts related to satisfying any mitigation requirements will be considered extra services.

Introduced on: August 10, 2021

Adopted on: August 10, 2021

Official Resolution#: R20210753

This task includes a review for the presence or absence of threatened or endangered species habitat based on research and a site visit. The subject site contains suitable habitat for protected bat species; therefore, it is expected that the NJDEP will prohibit or seasonally restrict the cutting of trees greater than five (5) inches diameter breast height (DBH). This proposal assumes that the project can comply with tree cutting restricts and that no further coordination or consultation with an agency is required. The Township of West Milford is a municipality with known occurrences of the protected species bog turtle (*Glyptemys muhlenbergii*) as per the NJDEP. Based on preliminary research, KSE anticipates that a Phase I Bog Turtle Habitat Investigation will not be required by the NJDEP/US Fish and Wildlife Service. If a Phase I investigation is required, it will be considered extra services and KSE will submit a separate proposal for this work upon request.

This proposal excludes any target species surveys for threatened or endangered plant or animal species, Phase IA Cultural Resource Investigation, and compensatory wetland mitigation services.

***KSE anticipates the agency permit filing fee to be \$1,000 for the General Permit.***

#### Task 4: NJDEP Flood Hazard Area Individual Permit Application

The proposed bridge replacement activity is regulated by NJDEP under the *Flood Hazard Area Control Act Rules* at NJAC 7:13. KSE assumes that due to the potential for the new bridge to be larger than existing due to expanded shoulders and/or addition of sidewalks, a Flood Hazard Area General Permit #10 is not applicable and an Individual Permit is required. ***Based on our review of existing information, it is expected that the NJDEP will require wildlife passage areas along the stream channel to be incorporated in the design.***

The Individual Permit application will include the required forms, figures, maps, photographs, Natural Heritage Program Letter, Environmental Report, Engineering Report demonstrating that flood elevations (HEC-RAS calculations) have been met along with proof of public notification, permit drawings, and public notices.

Note that Post Brook has a previously adopted detailed hydraulic study by both NJDEP and the Federal Emergency Management Agency (FEMA) as depicted on Flood Insurance Rate Map Panel 34031C0136F Effective 9/28/2007, and included in the Passaic County Flood Insurance Study, last revised 4/17/2020.

As a result of these past studies, KSE will utilize the hydrologic discharges previously developed for each flood storm event, to demonstrate hydraulic step backwater analysis utilizing HEC-RAS v 5.0 software for use to model and tie-into existing floodplain and floodway elevations as well as to determine the appropriate size and openings for the proposed replacement structure. Therefore, this proposal is prepared with the understanding that existing flood hazard area inundation mappings will be utilized as the basis to match the floodway and/or the flood hazard area and excludes the delineation of same using detailed calculations. This proposal has also been prepared with the understanding that flood storage volume displacement limit calculations will not be required for reconstruction improvements to a public roadway as per 7:13-11.4(d)3. Pursuant to NJAC 7:13-5.5(b)2, a Verification is not required and is excluded from this proposal.

***KSE anticipates the agency permit filing fee to be \$7,000 for the Individual Permit.***

#### Task 5: Highlands Applicability Determination (HAD)

West Milford Township in Passaic County is located entirely within the Preservation Area of the Highlands Region (51,848 acres). The project is considered a "Major Highlands Development" pursuant to the *Highlands Water Protection and Planning Act Rules* at NJAC 7:38 because the project is a capital project proposed by a local government unit in the preservation area that requires an environmental land use permit. However, the project is understood to qualify for Exemption #9 under the rules for the routine maintenance and operations, rehabilitation, preservation, reconstruction, or repair of transportation or infrastructure systems by a State entity or local government unit, provided that the activity is consistent with

Introduced on: August 10, 2021

Adopted on: August 10, 2021

Official Resolution#: R20210753

SECTION 1 – SCOPE OF SERVICES

Page 10 of 12

**KSE**

the goals and purposes of the Highlands Act, and does not result in the construction of any new through-capacity travel lanes. This proposal assumes that the project meets the requirements of this exemption. West Milford's Petition for Plan Conformance was approved by the New Jersey Highlands Council on February 17, 2011. However, the approved ordinance does not afford the municipality the authority to issue Exemption #9. As a result, KSE will prepare and submit a request to the NJDEP for a Highlands Applicability Determination (HAD). This proposal excludes the preparation and submission of an application for a Highlands Preservation Area Approval (HPPA). If required, this will be considered extra services.

***KSE anticipates the agency permit filing fee to be \$750 for the HAD.***

**Task 6: NJDEP State Historic Preservation Office Submission**

As indicated in the Request for Proposal (RFP), KSE will initiate consultation with the New Jersey Historic Preservation Office (NJHPO) by drafting a letter on behalf of Passaic County. The preparation of a Phase IA historical and archaeological survey report will then be performed as required by the NJHPO. The project archaeologist will meet the Secretary of the Interior's Professional Qualifications and Standards for Archaeology (36 CFR Part 61). The Phase IA historical and archaeological survey will be carried out in accordance with N.J.A.C. 7:4-8.4 through 8.5 and in compliance with the Secretary of the Interior's *Standards and Guidelines for Archaeology and Historic Preservation*. The results of this work will be presented in a report that meets the reporting guidelines of the NJHPO.

**PHASE IA HISTORICAL AND ARCHAEOLOGICAL SURVEY (IF REQUIRED)**

The purpose of the Phase IA historical and archaeological survey is to assess the potential for archaeological resources within the project site or limits of disturbance for the project and make recommendations for any further work that may be required. KSE will closely review project plans and make recommendations for further work (i.e. Phase IB survey) or no further work based on the location and nature of the proposed impacts.

This work will consist of the following tasks:

- o Background research on the NJHPO's online cultural resources geographic information system viewer (LUCY) to determine if previously identified historic properties and historic resources are present within or adjacent to the project site. Due to COVID-19 restrictions, research at the NJHPO may not be possible. RGA will make a good-faith effort to obtain the necessary files through an examination of NJDEP's online NJ-GeoWeb GIS application and information already in RGA's files.
- o A review of historic maps and atlases at the New Jersey State Library. RGA requests receipt of As-Built plans for the culvert, if available.
- o Consultation with interested parties, including county and local historical societies.
- o A site visit by the project archaeologist to examine the topographic setting and record existing conditions in the project site. Digital photographic documentation (i.e., representative photographs) of the bridge structure will also be conducted.
- o An assessment of sensitivity for pre-Contact and historic archaeological resources.
- o Preparation of a report detailing the results of the survey. The report will meet the NJHPO's standards for archaeological survey reports.

Should the NJHPO require a Phase IA historical and archaeological survey, the cost for such work will be considered extra services.

If required, the Phase IA historical and archaeological survey will be completed in approximately five (5) weeks from the receipt of project base maps and property access approval.

A supplemental scope of work will be submitted should the project site contain a high potential for archaeological resources and the NJHPO requests the completion of a Phase IB archaeological survey and/or historic architectural survey.

Task 7: Hudson-Essex-Passaic Soil Conservation District Certification

Due to construction disturbance areas anticipated to exceed 5000 square feet, this project will require a Hudson-Essex-Passaic Soil Conservation District Permit to be secured by KSE. We will coordinate and prepare the necessary District Application, Engineering report and Soil Erosion and Sediment Control Plans and Details required for permit certification. Any review comments from the District will be coordinated and addressed by KSE as needed to obtain the certification. The Standards for Soil Erosion Control in New Jersey, 2017 edition, will be used as the basis for erosion control measures identified on the Construction Plans along with specific notes or requirements specific to the District.

***KSE anticipates the agency permit filing fees to be \$725 for public construction disturbance areas up to 1 acre.***

If it is determined that the scope of the project needs to be changed or additional changes in permitting are required, KSE will identify the appropriate permits required and notify the client of the related costs, expenses, and filing fees prior to commencing the permitting process.

***KSE anticipates the total agency permit filing fees to be \$9,475 for the applications contained in this scope of services. The permit fees are not included in the lump sum design fee for this project. It is understood that permit application fees will be billed to the County as out of pocket expenses.***

Replacement of Otterhole Road Culvert No. 1600-148.  
Over Post Brook, Township Of West Milford  
County of Passaic

---

*KS Engineers, P.C.* proposes the following Lump Sum amount for the outlined scope of services as per Section 1 of our proposal. A breakdown of the Lump sum is available upon request.

Lump Sum Total: \$189,778.62

Introduced on: August 10, 2021  
~~Adopted on: August 10, 2021~~  
Official Resolution#: R20210753

CERTIFICATION OF AVAILABLE FUNDS

THIS IS TO CERTIFY THAT FUNDS ARE AVAILABLE AS FOLLOWS:

AMOUNT: \$189,778.62

APPROPRIATION: C-04-55-166-002-920

PURPOSE: Authorizing an award of contract to KS Engineers, P.C. for the Engineering Design Services for the Replacement of the Otterhole Road Culvert No. 1600-148 over Post Brook in the Township of West Milford.

  
Richard Cahill, Director of Finance

DATED: August 10, 2021

# County of Passaic Board of County Commissioners

OFFICE OF COUNTY COMMISSIONERS

Director Pasquale "Pat" Lepore  
Deputy Director Bruce James  
Assad R. Akhter  
John W. Bartlett  
Theodore O. Best, Jr.  
Terry Duffy  
Cassandra "Sandi" Lazzara

401 Grand Street  
Paterson, New Jersey 07505  
Tel: 973-881-4402  
Fax: 973-742-3746

Anthony J. De Nova III  
*Administrator*  
Matthew P. Jordan, Esq.  
*County Counsel*  
Louis E. Imhof, III, RMC  
*Clerk Of The Board*



## Public Meeting (Board Meeting)

Date: Aug 10, 2021 - 5:30 PM

Location: County Administration Building  
Webex - 220  
401 Grand Street  
Paterson, NJ 07505

Agenda: RESOLUTION AUTHORIZING AN AWARD OF CONTRACT TO COLLIERS ENGINEERING FOR THE ENGINEERING DESIGN SERVICES FOR THE REPLACEMET OF THE DAWES HIGHWAY BRIDGE NO. 1600-503 OVER RAMAPO RIVER ON THE BORDER OF THE BOROUGH OF POMPTON LAKES AND THE TOWNSHIP OF WAYNE, PURSUANT TO N.J.S.A. 40A:11-5, ET SEQ., ALL AS NOTED IN THE RESOLUTION.

THIS RESOLUTION WAS REQUESTED BY:

REVIEWED BY:

Anthony J. De Nova III  
COUNTY ADMINISTRATOR

APPROVED AS TO FORM AND LEGALITY:

Matthew P. Jordan, Esq.  
COUNTY COUNSEL

Public Works

COMMITTEE NAME

<b>Official Resolution#</b>	<b>R20210754</b>							
Meeting Date	08/10/2021							
Introduced Date	08/10/2021							
Adopted Date	08/10/2021							
Agenda Item	I-38							
CAF #	C-04-55-166-002-920							
Purchase Req. #								
Result	Adopted							
<b>COMMISSIONER</b>	<b>PRES.</b>	<b>ABS.</b>	<b>MOVE</b>	<b>SEC</b>	<b>AYE</b>	<b>NAY</b>	<b>ABST.</b>	<b>RECU.</b>
Lepore	✓				✓			
James	✓		✓		✓			
Akhter	✓			✓	✓			
Bartlett	✓				✓			
Best Jr.	✓				✓			
Duffy	✓				✓			
Lazzara	✓				✓			

PRES.= present ABS.= absent  
MOVE= moved SEC= seconded  
AYE= yes NAY= no ABST.= abstain  
RECU.= recuse

**RESOLUTION AUTHORIZING AN AWARD OF CONTRACT TO COLLIERS ENGINEERING FOR THE ENGINEERING DESIGN SERVICES FOR THE REPLACEMENT OF THE DAWES HIGHWAY BRIDGE NO. 1600-503 OVER RAMAPO RIVER ON THE BORDER OF THE BOROUGH OF POMPTON LAKES AND THE TOWNSHIP OF WAYNE, PURSUANT TO N.J.S.A. 40A:11-5, ET SEQ.**

**WHEREAS**, the County of Passaic (hereafter "County") is a government body incorporated pursuant to N.J.S.A. 40:18-1, et seq. and vested with all rights contained therein; and

**WHEREAS**, pursuant to N.J.S.A. 40:20-1, the Board of County Commissioners for the County of Passaic (hereafter "Board") is vested with decision making powers on behalf of the County; and

**WHEREAS**, pursuant to N.J.S.A. 40A:11-5, et seq. the County issued RFQ-21-009 seeking qualifications for a pool of engineers, architects, land surveyors, planners, landscape architects, and environmental health and safety engineers for calendar year 2021, to be hired on an as-needed basis, to provide professional services to the County; and

**WHEREAS**, pursuant to N.J.S.A. 19:44A-20.4, the County's request for qualifications is a fair and open process, specifically, the qualification for the pool of engineers, architects, land surveyors, planners, landscape architects, and environmental health and safety engineers for calendar year 2021 is publicly advertised, awarded under a process that provides for public solicitation of qualifications, established the basis of an award and disclosure process documented in writing prior to any solicitation, and is publicly opened and announced when awarded; and

**WHEREAS**, on December 8, 2020, the Board of County Commissioners of the County of Passaic (hereafter "Board") passed Resolution No. R20201102 qualifying a pool of engineers, architects, land surveyors, planners, landscape architects, and environmental health and safety engineers for calendar year 2021, as recommended by the Passaic County Engineer, to be hired on an as-needed basis, which included Colliers Engineering; and

**WHEREAS**, the County Engineer is recommending an award of contract to Colliers Engineering, for engineering design services for the Project, in an amount not to exceed two hundred seventeen thousand six hundred seventy dollars (\$217,670.00) as per the proposal dated June 22, 2021, which is attached and made part of this Resolution; and

**WHEREAS**, funds are available in Account No. C-04-55-166-002-920 or any other account that may be deemed appropriate by the Chief Financial Officer or his designee, and the availability of funds has been contingently certified by the Chief Financial Officer subject to sufficient funds being appropriated by the Board in the 2021 and/or subsequent years' County budget (s), which is attached to and made part of this Resolution; and

**WHEREAS**, this matter was discussed on July 28, 2021, by the Public Works Committee and is being recommended to the Board for approval.

**NOW, THEREFORE, LET IT BE RESOLVED**, pursuant to N.J.S.A 40A:11-5(1)(a)(i), that the Board of County Commissioners of the County of Passaic hereby authorizes the award of contract to Colliers Engineering for Engineering Design Services for the Replacement of the Dawes Highway Bridge No.1600-503 over the Ramapo River on the border of the Borough of Pompton Lakes and the Township of Wayne in an amount not to exceed two hundred seventeen thousand six hundred seventy dollars (\$217,670.00) as recommend by the Passaic County Engineer.

**LET IT BE FURTHER RESOLVED**, the Clerk of the Board shall print, in the official newspaper, a brief notice stating the nature, duration, service, and amount of the contract to Colliers Engineering and maintain a copy of the resolution on file and available for public inspection in the Office of the Clerk of the Board.

**LET IT BE FURTHER RESOLVED**, that the Clerk of the Board, County Counsel, and Director of the Board of County Commissioners are authorized to execute the contract and take any other steps necessary to carry out the purpose of this resolution.

NDA

August 10, 2021



## Scope Clarifications

Based on our understanding of the project, we offer the following clarifications on the County's Scope of Work dated June 22, 2021 (attached herewith In Section 6 of this Proposal):

### Field Survey

Colliers Engineering & Design will perform a detailed Route Survey along a portion of Dawes Highway for a minimum distance of 400 feet in each direction beyond the edges of the existing bridge structure. All of the work associated with this survey will take place under the direct supervision of a New Jersey Licensed Professional Land Surveyor and will include the following:

1. Survey traverse and level runs will originate and terminate on Control Monuments and Benchmarks if existing in the vicinity of the bridge structure that have been established by an approved agency.
2. Horizontal control will be tied to the NAD 83 New Jersey Plane Coordinate System.
3. Vertical Control will be tied to North American Vertical Datum – NAVD 1988. If NJDEP permit drawings require conversion to the National Geodetic Vertical Datum (NGVD), a conversion equation between the two vertical datums will be provided.
4. The Project/Bridge Centerline (CL) will be established as the right-of-way (ROW) CL where possible and the Bridge CL. The Project CL will be tied to ROW through station/offsets. Control points will be established as necessary to reference the project baseline.
5. A Project Base Map will be prepared to depict existing site conditions, limits of work, and means of access. Field survey will be performed detailing planimetric features and ROW pertinent to the preparation of base mapping and ROW plans for the proposed project. The base mapping will extend a minimum of 70 ft from the edge of the roadway on both sides of Dawes Highway.
6. A survey of existing features will be performed. It will include existing roadway elements, utility poles, drainage structures, guide rail, fences, signs and limits of wooded areas. Individual trees and specimen shrubs will be located within easement and taking parcel areas, and within the entire project survey area (including 50 ft from the edge of the roadway). Topography will be shown with 1-ft contour intervals.
7. Station and offset from centerline to existing visible and accessible drainage structures will be shown on the plan. The type of structure, type of casting, size and types of pipes entering the structure and inverts on accessible pipes will be recovered by field survey.
8. Roadway cross-sections will be taken at 50-ft intervals and will be provided for a minimum distance of 400 ft on the east and west approach, and will extend a minimum of 50 feet from the edge of existing pavement on each side of the roadway. Additional cross sections will be taken at 20-ft intervals adjacent to each side of the bridge within 100 feet of the bridge and cross sections will be taken at 50-ft intervals along the side streets.
9. Survey includes the intersection of Dawes Highway and Riveredge Drive.
10. A separate cross section will be taken at each driveway. Spot grades will be taken to establish the centerline profile of the driveways from the road centerline extending 75 ft up the driveway.

## Scope Clarifications

Representative samples obtained from the explorations will be subjected to limited laboratory testing to evaluate general engineering characteristics. Such testing will likely include moisture contents, grain-size analysis, Atterberg Limits. We will coordinate with the County's On-Call Testing geotechnical consultant to perform the laboratory testing.

We will prepare a geotechnical report summarizing the subsurface conditions encountered at the site. The report will include the results of the subsurface exploration programs and laboratory testing, and geotechnical recommendations including:

- Recommended foundation types and corresponding capacity.
- Bearing strata.
- Seismic design Parameters (based on SPT-N values only).
- Lateral earth pressure coefficients.
- Excavation support systems.
- Construction dewatering, if required.
- Considerations for construction, such as for subgrade preparation.

### Permitting

#### 1. FRESHWATER WETLAND DELINEATION AND THREATENED AND ENDANGERED SPECIES REVIEW

To clarify the Highlands Applicability Determination, Freshwater Wetland and Flood Hazard Area permit requirements, Colliers Engineering & Design will prepare and submit to the NJDEP a request for a pre-application conference call, which will include the following:

- a) A project description.
- b) A plan view of the project.
- c) A tax lot and block designation of the site.
- d) The location of the project site, including the municipality and county.
- e) The general or surveyed location of freshwater wetlands transition areas and State open waters.
- f) A copy of the appropriate United States Soil Conservation Service map(s); and
- g) A United States Geological Survey quadrangle map showing the site.

Two (2) staff from Colliers Engineering & Design, including an engineer and environmental permitting professional, will attend the pre-application call.

Colliers Engineering & Design will delineate freshwater wetlands within 150 ft of the bridge replacement using the three-parameter approach (vegetation, soils, hydrology) described in the Federal Manual for Identifying and Delineating Jurisdictional Wetlands. This work will involve flagging the freshwater wetland boundary with numbered surveyor's ribbon (to be located by survey under a separate task) and will include the following information:

- a) Characterizing the soils of the wetland and upland areas including a statement on their hydric or non-hydric nature based upon Munsell Soil Color Chart readings.
- b) Characterizing the upland and wetland communities based upon vegetation and compiling a general list of plant species on the property with an indication of their associated abundance in the wetland and upland communities.
- c) Characterizing the hydrology of the wetland and upland areas on the property.

## Scope Clarifications

### 4. HIGHLANDS APPLICABILITY DETERMINATION

The project site is located within the Highlands Preservation Area; however, the proposed activities appear to qualify for an exemption for the routine maintenance and operations, rehabilitation, preservation, reconstruction, or repair of transportation or infrastructure systems by a State entity or local government unit, provided that the activity is consistent with the goals and purposes of the Highlands Water Protection and Planning Act and does not result in the construction of any new through-capacity travel lanes of 2,640 feet or more not including tapers.

Accordingly, Colliers Engineering & Design will prepare and submit a request to the NJDEP for a Highlands Applicability Determination, which will consist of the information described in the NJDEP Application Checklist for a Highlands Applicability Determination, which includes:

- Highlands Applicability Determination application form.
- USGS, Road, and Tax Maps.
- Preparation of public notices.
- Application fee (to be provided by applicant).
- A site plan certified by the appropriate licensed New Jersey Professional engineer or land surveyor showing the existing and proposed transportation or infrastructure system.
- A written description of the work to be conducted, the purpose of the activity and how that purpose is consistent with the goals and purposes of Highlands Water Protection and Planning Act.
- A brief description of the State entity or local government unit that is sponsoring and overseeing the proposed activities.

The Highlands Applicability Determination is required to demonstrate the proposed activities are exempt from requiring a Highlands Preservation Area Approval and needs to be obtained before the applicant can proceed with obtaining the required freshwater wetland and flood hazard area approvals pursuant to N.J.A.C. 7:7A and N.J.A.C. 7:13. **If the NJDEP determines that the proposed activities are not exempt, a Highlands Preservation Area Approval will be required; a separate scope and fee proposal will be provided in this case.**

### 5. GREEN ACRES

According to our preliminary research Block 9520 Lots 12 and 14 are located within the jurisdiction area of the Green Acres per the NJDEP's Green Acres & Open Space Inventory, available online. Therefore, we assume that all work at this side of the bridge will be within the existing ROW, which is 50-ft wide per available tax maps.

### 6. STORMWATER MANAGEMENT PERMIT

This Proposal assumes that the project will not be a Major Development and, therefore, the Stormwater Management permit will not be required.

## Scope Clarifications

### Bridge Railing

Colliers Engineering & Design will coordinate with the County, HPO and both municipalities the type of the concrete railing, which would be the most desirable at this site due to its historical sensitivity. We may replicate the existing patterns or suggest a Texas-style open baluster railing and pylons.

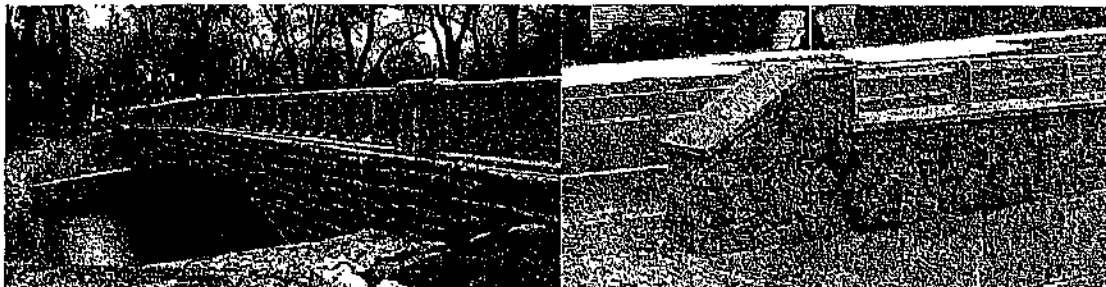

Use of natural stone veneer or form liners on the exposed surfaces will be considered as well.

### Historic Preservation Office (HPO)

Prior to NJDEP permit submission, Colliers Engineering & Design will coordinate the project with HPO and prepare the submission, as outlined in Section F.4 of the RFP. However, upon our preliminary research, it appears that the project is located within the Morris Canal – a historic property listed in New Jersey Register and National Register of Historic Places. The bridge itself is a contributing element to the Morris Canal. The project will most likely trigger the New Jersey Register of Historic Places Act, which entails the completion of an Application for Project Authorization (APA) to enable the NJHPO to determine if the project will constitute an encroachment to an archaeological or architectural (or both, as is the case with the Morris Canal) New Jersey Register-listed historic property. The APA components include a certified list of property owners within 200 feet of the project, an affects assessment to the historic property, an alternatives analysis, detailed project description with finalized plans, and supporting documentation, including at a minimum of Phase IA archaeological survey.

The Phase IA archeological survey would also be needed to initiate consultation with the HPO as part of the Freshwater Wetland permit. If the proposed bridge will be confined to the existing bridge footprint, it's likely that an historic architectural survey beyond the data provided in the APA document may not be necessary.

If requested by NJDEP/HPO, Richard Grubb and Associates, Inc. (RGA), a sub-consultant to Colliers Engineering & Design, will prepare a Phase IA historical and archaeological survey (i.e. research, site visit, sensitivity assessment) in connection with the proposed replacement of the Dawes Highway Bridge.

*Please note that only HPO notification effort, outlined in Section F.4 of the RFP is included in this proposal. The cost of all other work is shown in "if & where directed".*

CERTIFICATION OF AVAILABLE FUNDS

THIS IS TO CERTIFY THAT FUNDS ARE AVAILABLE AS FOLLOWS:

AMOUNT: \$217,670.00

APPROPRIATION: C-04-55-166-002-920

PURPOSE: Authorizing an award of contract to Colliers Engineering for Engineering and Design Services for the Replacement of the Dawes Highway Bridge No. 1600-503 over the Ramapo River on the boarder of the Borough of Pompton Lakes and the Township of Wayne.

  
Richard Cahill, Director of Finance

DATED: August 10, 2021

# County of Passaic Board of County Commissioners

OFFICE OF COUNTY COMMISSIONERS

Director Pasquale "Pat" Lepore  
Deputy Director Bruce James  
Assad R. Akhter  
John W. Bartlett  
Theodore O. Best, Jr.  
Terry Duffy  
Cassandra "Sandi" Lazzara

401 Grand Street  
Paterson, New Jersey 07505

Tel: 973-881-4402  
Fax: 973-742-3746

Anthony J. De Nova III  
Administrator

Matthew P. Jordan, Esq.  
County Counsel

Louis E. Imhof, III, RMC  
Clerk Of The Board



## Public Meeting (Board Meeting)

Date: Aug 10, 2021 - 5:30 PM

Location: County Administration Building  
Webex - 220  
401 Grand Street  
Paterson, NJ 07505

Agenda: RESOLUTION AUTHORIZING THE PURCHASING AGENT TO ADVERTISE AND RECEIVE BIDS FOR INSTALLATION OF EMERGENCY GENERATOR AT 40-60 COLUMBIA AVENUE IN THE CITY OF PATERSON, PURSUANT TO N.J.S.A. 40A:11-1, ET SEQ., ALL AS NOTED IN THE RESOLUTION.

THIS RESOLUTION WAS REQUESTED BY:

REVIEWED BY:

Anthony J. De Nova III  
COUNTY ADMINISTRATOR

APPROVED AS TO FORM AND LEGALITY:

Matthew P. Jordan, Esq.  
COUNTY COUNSEL

Public Works

COMMITTEE NAME

<b>Official Resolution#</b>	<b>R20210755</b>							
Meeting Date	08/10/2021							
Introduced Date	08/10/2021							
Adopted Date	08/10/2021							
Agenda Item	I-39							
CAF #								
Purchase Req. #								
Result	Adopted							
<b>COMMISSIONER</b>	<b>PRES.</b>	<b>ABS.</b>	<b>MOVE</b>	<b>SEC</b>	<b>AYE</b>	<b>NAY</b>	<b>ABST.</b>	<b>RECU.</b>
Lepore	✓				✓			
James	✓		✓		✓			
Akhter	✓			✓	✓			
Bartlett	✓				✓			
Best Jr.	✓				✓			
Duffy	✓				✓			
Lazzara	✓				✓			

PRES.= present ABS.= absent  
 MOVE= moved SEC= seconded  
 AYE= yes NAY= no ABST.= abstain  
 RECU.= recuse

Dated: August 11, 2021

**RESOLUTION AUTHORIZING THE PURCHASING AGENT TO ADVERTISE AND RECEIVE BIDS FOR INSTALLATION OF EMERGENCY GENERATOR AT 40-60 COLUMBIA AVENUE IN THE CITY OF PATERSON, PURSUANT TO N.J.S.A. 40A:11-1, ET SEQ.**

**WHEREAS**, the County of Passaic (hereafter “County”) is a body politic and corporate pursuant to N.J.S.A. 40:18-1 and vested with all rights contained therein; and

**WHEREAS**, pursuant to N.J.S.A. 40:20-1 the Board of County Commissioners of the County of Passaic (hereafter “Board”) is vested with managing the property, finances, and affairs of the County; and

**WHEREAS**, the specifications for the Installation of the Emergency Generator Project at 40-60 Columbia Avenue in the City of Paterson have been prepared and conform with County and industry engineering standards, and the County Engineer is requesting that Purchasing Agent advertise and receive bids for same, in compliance with N.J.S.A. 40A:11-1, et seq.; and

**WHEREAS**, pursuant to N.J.S.A. 40A:11-23, et seq. the County shall publish the advertisement for bids in advance of the date fixed for receiving the bids to promote competitive bidding; and

**WHEREAS**, this matter was discussed on July 28, 2021, by the Public Works Committee and is being recommended to the Board for approval.

**NOW, THEREFORE, LET IT BE RESOLVED**, pursuant to N.J.S.A. 40A:11-1, et seq., that the Board of County Commissioners of the County of Passaic authorizes the Purchasing Agent to advertise and receive bids for the Installation of Emergency Generator at 40-60 Columbia Avenue in the City of Paterson, in compliance with the law.

**LET IT FURTHER BE RESOLVED**, that the Purchasing Agent shall publish the advertisement for the bids in advance of the date fixed for receiving bids to promote competitive bidding, in compliance with N.J.S.A. 40A:11-23, et seq.

**LET IT BE FURTHER RESOLVED**, that the Clerk of the Board, County Counsel, County Engineer, and Purchasing Agent are authorized to take any action necessary to carry out the purpose of this Resolution.

NDA

August 10, 2021

# County of Passaic Board of County Commissioners

OFFICE OF COUNTY COMMISSIONERS

Director Pasquale "Pat" Lepore  
Deputy Director Bruce James  
Assad R. Akhter  
John W. Bartlett  
Theodore O. Best, Jr.  
Terry Duffy  
Cassandra "Sandi" Lazzara

401 Grand Street  
Paterson, New Jersey 07505  
Tel: 973-881-4402  
Fax: 973-742-3746

Anthony J. De Nova III  
*Administrator*  
Matthew P. Jordan, Esq.  
*County Counsel*  
Louis E. Imhof, III, RMC  
*Clerk Of The Board*



## Public Meeting (Board Meeting)

Date: Aug 10, 2021 - 5:30 PM

Location: County Administration Building  
Webex - 220  
401 Grand Street  
Paterson, NJ 07505

Agenda: RESOLUTION AUTHORIZING THE PURCHASING AGENT TO ADVERTISE AND RECEIVE BIDS FOR THE CHILLERS REPLACEMENT AT 401 GRAND STREET CITY OF PATERSON, PURSUANT TO N.J.S.A. 40A:11-1, ET SEQ., ALL AS NOTED IN THE RESOLUTION.

THIS RESOLUTION WAS REQUESTED BY:

REVIEWED BY:

Anthony J. De Nova III  
COUNTY ADMINISTRATOR

APPROVED AS TO FORM AND LEGALITY:

Matthew P. Jordan, Esq.  
COUNTY COUNSEL

Public Works

COMMITTEE NAME

<b>Official Resolution#</b>	<b>R20210756</b>							
Meeting Date	08/10/2021							
Introduced Date	08/10/2021							
Adopted Date	08/10/2021							
Agenda Item	I-40							
CAF #								
Purchase Req. #								
Result	Adopted							
<b>COMMISSIONER</b>	<b>PRES.</b>	<b>ABS.</b>	<b>MOVE</b>	<b>SEC</b>	<b>AYE</b>	<b>NAY</b>	<b>ABST.</b>	<b>RECU.</b>
Lepore	✓				✓			
James	✓		✓		✓			
Akhter	✓			✓	✓			
Bartlett	✓				✓			
Best Jr.	✓				✓			
Duffy	✓				✓			
Lazzara	✓				✓			

PRES.= present ABS.= absent  
MOVE= moved SEC= seconded  
AYE= yes NAY= no ABST.= abstain  
RECU.= recuse

**Dated: August 11, 2021**



**RESOLUTION AUTHORIZING THE PURCHASING AGENT TO ADVERTISE AND RECEIVE BIDS FOR THE CHILLERS REPLACEMENT AT 401 GRAND STREET CITY OF PATERSON, PURSUANT TO N.J.S.A. 40A:11-1, ET SEQ.**

**WHEREAS**, the County of Passaic (hereafter “County”) is a body politic and corporate pursuant to N.J.S.A. 40:18-1 and vested with all rights contained therein; and

**WHEREAS**, pursuant to N.J.S.A. 40:20-1 the Board of County Commissioners of the County of Passaic (hereafter “Board”) is vested with managing the property, finances, and affairs of the County; and

**WHEREAS**, the specifications for the Chillers Replacement at 401 Grand Street in the City of Paterson have been prepared and conform with County and industry engineering standards, and the County Engineer is requesting that Purchasing Agent advertise and receive bids for same, in compliance with N.J.S.A. 40A:11-1, et seq.; and

**WHEREAS**, pursuant to N.J.S.A. 40A:11-23, et seq. the County shall publish the advertisement for bids in advance of the date fixed for receiving the bids to promote competitive bidding; and

**WHEREAS**, this matter was discussed on July 28, 2021, by the Public Works Committee and is being recommended to the Board for approval.

**NOW, THEREFORE, LET IT BE RESOLVED**, pursuant to N.J.S.A. 40A:11-1, et seq., that the Board of County Commissioners of the County of Passaic authorizes the Purchasing Agent to advertise and receive bids for the Chillers Replacement at 401 Grand Street in the City of Paterson, in compliance with the law.

**LET IT FURTHER BE RESOLVED**, that the Purchasing Agent shall publish the advertisement for the bids in advance of the date fixed for receiving bids to promote competitive bidding, in compliance with N.J.S.A. 40A:11-23, et seq.

**LET IT BE FURTHER RESOLVED**, that the Clerk of the Board, County Counsel, County Engineer, and Purchasing Agent are authorized to take any action necessary to carry out the purpose of this Resolution.

NDA

August 10, 2021

# County of Passaic Board of County Commissioners

OFFICE OF COUNTY COMMISSIONERS

Director Pasquale "Pat" Lepore  
Deputy Director Bruce James  
Assad R. Akhter  
John W. Bartlett  
Theodore O. Best, Jr.  
Terry Duffy  
Cassandra "Sandi" Lazzara

401 Grand Street  
Paterson, New Jersey 07505

Tel: 973-881-4402  
Fax: 973-742-3746

Anthony J. De Nova III  
Administrator

Matthew P. Jordan, Esq.  
County Counsel

Louis E. Imhof, III, RMC  
Clerk Of The Board



## Public Meeting (Board Meeting)

Date: Aug 10, 2021 - 5:30 PM

Location: County Administration Building  
Webex - 220  
401 Grand Street  
Paterson, NJ 07505

Agenda: RESOLUTION AUTHORIZING THE PURCHASING AGENT TO ADVERTISE AND RECEIVE BIDS FOR THE RECONSTRUCTION OF PATERSON HAMBURG TURNPIKE & ALPS ROAD INTERSECTION PROJECT IN THE TOWNSHIP OF WAYNE, NEW JERSEY, PURSUANT TO N.J.S.A 40A: 11-1, ET SEQ., ALL AS NOTED IN THE RESOLUTION.

THIS RESOLUTION WAS REQUESTED BY:

REVIEWED BY:

Anthony J. De Nova III  
COUNTY ADMINISTRATOR

APPROVED AS TO FORM AND LEGALITY:

Matthew P. Jordan, Esq.  
COUNTY COUNSEL

Public Works  
COMMITTEE NAME

<b>Official Resolution#</b>	<b>R20210757</b>							
Meeting Date	08/10/2021							
Introduced Date	08/10/2021							
Adopted Date	08/10/2021							
Agenda Item	I-41							
CAF #								
Purchase Req. #								
Result	Adopted							
<b>COMMISSIONER</b>	<b>PRES.</b>	<b>ABS.</b>	<b>MOVE</b>	<b>SEC</b>	<b>AYE</b>	<b>NAY</b>	<b>ABST.</b>	<b>RECU.</b>
Lepore	✓				✓			
James	✓		✓		✓			
Akhter	✓			✓	✓			
Bartlett	✓				✓			
Best Jr.	✓				✓			
Duffy	✓				✓			
Lazzara	✓				✓			

PRES.= present ABS.= absent  
MOVE= moved SEC= seconded  
AYE= yes NAY= no ABST.= abstain  
RECU.= recuse

**Dated: August 11, 2021**

**RESOLUTION AUTHORIZING THE PURCHASING AGENT TO ADVERTISE AND RECEIVE BIDS FOR THE RECONSTRUCTION OF PATERSON HAMBURG TURNPIKE & ALPS ROAD INTERSECTION PROJECT IN THE TOWNSHIP OF WAYNE, NEW JERSEY, PURSUANT TO N.J.S.A 40A: 11-1, ET SEQ.**

**WHEREAS**, the County of Passaic (hereafter “County”) is a body politic and corporate pursuant to N.J.S.A. 40:18-1 and vested with all rights contained therein; and

**WHEREAS**, pursuant to N.J.S.A. 40:20-1 the Board of County Commissioners of the County of Passaic (hereafter “Board”) is vested with managing the property, finances, and affairs of the County; and

**WHEREAS**, the specifications for the reconstruction of Paterson Hamburg Turnpike and Alps Road Project have been prepared and conform with County and industry engineering standards, and the County Engineer is requesting that Purchasing Agent advertise and receive bids for same, in compliance with N.J.S.A. 40A:11-1, et seq.; and

**WHEREAS**, pursuant to N.J.S.A. 40A:11-23, et seq. the County shall publish the advertisement for bids in advance of the date fixed for receiving the bids to promote competitive bidding; and

**WHEREAS**, this matter was discussed on July 28, 2021, by the Public Works Committee and is being recommended to the Board for approval.

**NOW, THEREFORE, LET IT BE RESOLVED**, pursuant to N.J.S.A. 40A:11-1, et seq., that the Board of County Commissioners of the County of Passaic authorizes the Purchasing Agent to advertise and receive bids for the Reconstruction of Paterson Hamburg Turnpike and Alps Road Intersection Project in the Township of Wayne in compliance with the law.

**LET IT FURTHER BE RESOLVED**, that the Purchasing Agent shall publish the advertisement for the bids in advance of the date fixed for receiving bids to promote competitive bidding, in compliance with N.J.S.A. 40A:11-23, et seq.

**LET IT BE FURTHER RESOLVED**, that the Clerk of the Board, County Counsel, County Engineer, and Purchasing Agent are authorized to take any action necessary to carry out the purpose of this Resolution.

NDA

August 10, 2021

# County of Passaic Board of County Commissioners

OFFICE OF COUNTY COMMISSIONERS

Director Pasquale "Pat" Lepore  
Deputy Director Bruce James  
Assad R. Akhter  
John W. Bartlett  
Theodore O. Best, Jr.  
Terry Duffy  
Cassandra "Sandi" Lazzara

401 Grand Street  
Paterson, New Jersey 07505

Tel: 973-881-4402  
Fax: 973-742-3746

Anthony J. De Nova III  
Administrator

Matthew P. Jordan, Esq.  
County Counsel

Louis E. Imhof, III, RMC  
Clerk Of The Board



## Public Meeting (Board Meeting)

Date: Aug 10, 2021 - 5:30 PM

Location: County Administration Building  
Webex - 220  
401 Grand Street  
Paterson, NJ 07505

Agenda: RESOLUTION AUTHORIZING THE PURCHASING AGENT TO ADVERTISE AND RECEIVE BIDS FOR THE GARRET MOUNTAIN RESERVATION IMPROVEMENTS PHASE II PROJECT IN THE CITY OF PATERSON AND THE BOROUGH OF WOODLAND PARK, PURSUANT TO N.J.S.A. 40A:11-1, ET SEQ., ALL AS NOTED IN THE RESOLUTION.

THIS RESOLUTION WAS REQUESTED BY:

REVIEWED BY:

Anthony J. De Nova III  
COUNTY ADMINISTRATOR

APPROVED AS TO FORM AND LEGALITY:

Matthew P. Jordan, Esq.  
COUNTY COUNSEL

Public Works

COMMITTEE NAME

<b>Official Resolution#</b>	<b>R20210758</b>							
Meeting Date	08/10/2021							
Introduced Date	08/10/2021							
Adopted Date	08/10/2021							
Agenda Item	I-42							
CAF #								
Purchase Req. #								
Result	Adopted							
<b>COMMISSIONER</b>	<b>PRES.</b>	<b>ABS.</b>	<b>MOVE</b>	<b>SEC</b>	<b>AYE</b>	<b>NAY</b>	<b>ABST.</b>	<b>RECU.</b>
Lepore	✓				✓			
James	✓		✓		✓			
Akhter	✓			✓	✓			
Bartlett	✓				✓			
Best Jr.	✓				✓			
Duffy	✓				✓			
Lazzara	✓				✓			

PRES.= present ABS.= absent  
MOVE= moved SEC= seconded  
AYE= yes NAY= no ABST.= abstain  
RECU.= recuse

Dated: August 11, 2021

**RESOLUTION AUTHORIZING THE PURCHASING AGENT TO ADVERTISE AND RECEIVE BIDS FOR THE GARRET MOUNTAIN RESERVATION IMPROVEMENTS PHASE II PROJECT IN THE CITY OF PATERSON AND THE BOROUGH OF WOODLAND PARK, PURSUANT TO N.J.S.A. 40A:11-1, ET SEQ.**

**WHEREAS**, the County of Passaic (hereafter “County”) is a body politic and corporate pursuant to N.J.S.A. 40:18-1 and vested with all rights contained therein; and

**WHEREAS**, pursuant to N.J.S.A. 40:20-1 the Board of County Commissioners of the County of Passaic (hereafter “Board”) is vested with managing the property, finances, and affairs of the County; and

**WHEREAS**, the specifications for the Garret Mountain Reservation Improvements Phase II Project have been prepared and conform with County and industry engineering standards, and the County Engineer is requesting that Purchasing Agent advertise and receive bids for same, in compliance with N.J.S.A. 40A:11-1, et seq.; and

**WHEREAS**, pursuant to N.J.S.A. 40A:11-23, et seq. the County shall publish the advertisement for bids in advance of the date fixed for receiving the bids to promote competitive bidding; and

**WHEREAS**, this matter was discussed on July 28, 2021, by the Public Works Committee and is being recommended to the Board for approval.

**NOW, THEREFORE, LET IT BE RESOLVED**, pursuant to N.J.S.A. 40A:11-1, et seq., that the Board of County Commissioners of the County of Passaic authorizes the Purchasing Agent to advertise and receive bids for the Garret Mountain Reservation Improvement Phase II Project in compliance with the law.

**LET IT FURTHER BE RESOLVED**, that the Purchasing Agent shall publish the advertisement for the bids in advance of the date fixed for receiving bids to promote competitive bidding, in compliance with N.J.S.A. 40A:11-23, et seq.

**LET IT BE FURTHER RESOLVED**, that the Clerk of the Board, County Counsel, County Engineer, and Purchasing Agent are authorized to take any action necessary to carry out the purpose of this Resolution.

NDA

August 10, 2021

# County of Passaic Board of County Commissioners

OFFICE OF COUNTY COMMISSIONERS

Director Pasquale "Pat" Lepore  
Deputy Director Bruce James  
Assad R. Akhter  
John W. Bartlett  
Theodore O. Best, Jr.  
Terry Duffy  
Cassandra "Sandi" Lazzara

401 Grand Street  
Paterson, New Jersey 07505

Tel: 973-881-4402  
Fax: 973-742-3746

Anthony J. De Nova III  
Administrator

Matthew P. Jordan, Esq.  
County Counsel

Louis E. Imhof, III, RMC  
Clerk Of The Board



## Public Meeting (Board Meeting)

Date: Aug 10, 2021 - 5:30 PM

Location: County Administration Building  
Webex - 220  
401 Grand Street  
Paterson, NJ 07505

Agenda: RESOLUTION AUTHORIZING THE TRANSFER OF A SURPLUS VEHICLE FROM THE PASSAIC COUNTY SHERIFF'S OFFICE FLEET TO WILLIAM PATERSON UNIVERSITY, PURSUANT TO N.J.S.A. 40A:11-36(2), ALL AS NOTED IN THE RESOLUTION.

THIS RESOLUTION WAS REQUESTED BY:

SHERIFF'S DEPT

REVIEWED BY:

Anthony J. De Nova III

COUNTY ADMINISTRATOR

APPROVED AS TO FORM AND LEGALITY:

Matthew P. Jordan, Esq.

COUNTY COUNSEL

Law and Public Safety

COMMITTEE NAME

<b>Official Resolution#</b>	<b>R20210759</b>							
Meeting Date	08/10/2021							
Introduced Date	08/10/2021							
Adopted Date	08/10/2021							
Agenda Item	I-43							
CAF #								
Purchase Req. #								
Result	Adopted							
<b>COMMISSIONER</b>	<b>PRES.</b>	<b>ABS.</b>	<b>MOVE</b>	<b>SEC</b>	<b>AYE</b>	<b>NAY</b>	<b>ABST.</b>	<b>RECU.</b>
Lepore	✓				✓			
James	✓		✓		✓			
Akhter	✓			✓	✓			
Bartlett	✓				✓			
Best Jr.	✓				✓			
Duffy	✓				✓			
Lazzara	✓				✓			

PRES.= present ABS.= absent  
MOVE= moved SEC= seconded  
AYE= yes NAY= no ABST.= abstain  
RECU.= recuse

**Dated: August 11, 2021**

**RESOLUTION AUTHORIZING THE TRANSFER OF A SURPLUS VEHICLE FROM THE PASSAIC COUNTY SHERIFF'S OFFICE FLEET TO WILLIAM PATERSON UNIVERSITY, PURSUANT TO N.J.S.A. 40A:11-36(2)**

**WHEREAS**, the County of Passaic (hereafter "County") is a body politic and corporate pursuant to N.J.S.A. 40:18-1 and vested with all rights contained therein; and

**WHEREAS**, pursuant to N.J.S.A. 40:20-1 the Board of County Commissioners of the County of Passaic (hereafter "Board") is vested with managing the property, finances, and affairs of the County; and

**WHEREAS**, pursuant to N.J.S.A. 40A:11-36 any contracting unit by resolution of its governing body may authorize by sealed bid or public auction the sale of its personal property not needed for public use; and

**WHEREAS**, more specifically, pursuant to N.J.S.A. 40A:11-36(2) whenever the transfer of such surplus property is to another contracting unit, the law does not require the use of a sealed bid or public auction; and

**WHEREAS**, William Paterson University, as another contracting unit, has inquired about the availability of any surplus vehicles that may be available from the Passaic County Sheriff's Office ("PCSO") for transfer in accordance with N.J.S.A. 40A:11-36(2); and

**WHEREAS**, the PCSO has identified a 2008 Dodge Charger, vin # 2B3KA3H08H320149, which is available for said transfer, and now seeks approval of the Board to accomplish same; and

**WHEREAS**, this matter has been reviewed by the Law and Public Safety Committee at its August 3, 2021 meeting and is being recommended to the Board of for approval; and

**NOW, THEREFORE, LET IT BE RESOLVED**, that the Board of County Commissioners of the County of Passaic hereby authorizes the Passaic County Sheriff's Office to transfer its surplus vehicle, namely a 2008 Dodge Charger, vin # 2B3KA3H08H320149, to William Paterson University pursuant to N.J.S.A. 40A:11-36(2).

**LET IT BE FURTHER RESOLVED**, that the Sheriff or his designee, Director of the Board of County Commissioners, County Administrator, County Counsel, Clerk of the Board, Chief Financial Officer, and any other employee for the County of Passaic may take any action necessary to effectuate the purpose of this resolution.

LSP

August 10, 2021

# County of Passaic Board of County Commissioners

OFFICE OF COUNTY COMMISSIONERS

Director Pasquale "Pat" Lepore  
Deputy Director Bruce James  
Assad R. Akhter  
John W. Bartlett  
Theodore O. Best, Jr.  
Terry Duffy  
Cassandra "Sandi" Lazzara

401 Grand Street  
Paterson, New Jersey 07505  
Tel: 973-881-4402  
Fax: 973-742-3746

Anthony J. De Nova III  
*Administrator*  
Matthew P. Jordan, Esq.  
*County Counsel*  
Louis E. Imhof, III, RMC  
*Clerk Of The Board*



## Public Meeting (Board Meeting)

Date: Aug 10, 2021 - 5:30 PM

Location: County Administration Building  
Webex - 220  
401 Grand Street  
Paterson, NJ 07505

Agenda: RESOLUTION AUTHORIZING THE PASSAIC COUNTY SHERIFF'S OFFICE TO APPLY FOR AND ACCEPT FUNDS FROM THE STATE OF NEW JERSEY DEPARTMENT OF LAW AND PUBLIC SAFETY OFFICE OF THE ATTORNEY GENERAL SFY21 BODY-WORN CAMERA GRANT PROGRAM, PURSUANT TO N.J.S.A. 40:20-1, ALL AS NOTED IN THE RESOLUTION.

THIS RESOLUTION WAS REQUESTED BY:

SHERIFF'S DEPT

REVIEWED BY:

  
Anthony J. De Nova III

COUNTY ADMINISTRATOR

APPROVED AS TO FORM AND LEGALITY:

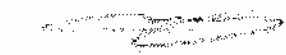
  
Matthew P. Jordan, Esq.

COUNTY COUNSEL

Law and Public Safety

COMMITTEE NAME

<b>Official Resolution#</b>	<b>R20210760</b>							
Meeting Date	08/10/2021							
Introduced Date	08/10/2021							
Adopted Date	08/10/2021							
Agenda Item	I-44							
CAF #								
Purchase Req. #								
Result	Adopted							
<b>COMMISSIONER</b>	<b>PRES.</b>	<b>ABS.</b>	<b>MOVE</b>	<b>SEC</b>	<b>AYE</b>	<b>NAY</b>	<b>ABST.</b>	<b>RECU.</b>
Lepore	✓				✓			
James	✓		✓		✓			
Akhter	✓			✓	✓			
Bartlett	✓				✓			
Best Jr.	✓				✓			
Duffy	✓				✓			
Lazzara	✓				✓			

PRES.= present ABS.= absent  
MOVE= moved SEC= seconded  
AYE= yes NAY= no ABST.= abstain  
RECU.= recuse

Dated: August 11, 2021



**RESOLUTION AUTHORIZING THE PASSAIC COUNTY SHERIFF'S OFFICE TO APPLY FOR AND ACCEPT FUNDS FROM THE STATE OF NEW JERSEY DEPARTMENT OF LAW AND PUBLIC SAFETY OFFICE OF THE ATTORNEY GENERAL SFY21 BODY-WORN CAMERA GRANT PROGRAM, PURSUANT TO N.J.S.A. 40:20-1**

**WHEREAS**, the County of Passaic (hereinafter the "County") is a body politic and corporate pursuant to N.J.S.A. 40:18-1 and vested with all rights contained therein; and

**WHEREAS**, pursuant to N.J.S.A. 40:20-1 the Board of County Commissioner of the County of Passaic (hereinafter the "Board") is vested with managing the property, finances, and affairs of the County; and

**WHEREAS**, the Passaic County Sheriff's Office (hereinafter "PCSO") seeks permission to apply and accept funds in the amount of four hundred and eighty-nine thousand one hundred and twenty dollars (\$489,120.00) through the SFY21 Body-Worn Camera Grant Program to be used for the purchase of body worn cameras; and

**WHEREAS**, this matter was discussed at the Law and Public Safety Committee meeting held on August 3, 2021 and is being recommended to the Board for approval; and

**NOW, THEREFORE, LET IT BE RESOLVED** that the Board of County Commissioners for the County of Passaic hereby authorizes the Passaic County Sheriff's Office to apply and accept funds in the amount of four hundred and eighty-nine thousand one hundred and twenty dollars (\$489,120.00) through the SFY21 Body-Worn Camera Grant Program to be used for the purchase of body worn cameras.

**LET IT BE FURTHER RESOLVED**, that the Passaic County Sheriff's Office shall use the funds received for the purposes set forth in its application for the receipt of said grant funds and as set forth in this resolution.

**LET IT BE FURTHER RESOLVED**, that the Clerk of the Board, County Counsel, County Administrator, Passaic County Sheriff, and Director of the Board of County Commissioners are authorized to execute an agreement and take any other steps necessary to carry out the purpose of this resolution.

LSP

August 10, 2021

STATE OF NEW JERSEY  
DEPARTMENT OF LAW AND PUBLIC SAFETY  
OFFICE OF THE ATTORNEY GENERAL

**SFY21 BODY-WORN CAMERA  
GRANT PROGRAM**

**GENERAL CONDITIONS**

1. **Legal Authority for the Application:** The Grantee agrees that it possesses legal authority to apply for the grant; and that, if applicable, a resolution or similar action has been duly adopted or passed as an official act of the applicant's governing body, authorizing the filing of the application, including all understandings and assurances contained therein, and directing and authorizing the person identified as the official representative of the applicant to act in connection with the application and to provide such additional information as may be required. The Grantee agrees that it has the institutional, managerial, and financial capability (including funds sufficient to pay any required non-State share of project cost) to ensure proper planning, management, and completion of the project described in this application.
2. **Compliance with State and Federal Laws:** The Grantee agrees to comply with all requirements imposed by the Department of Law and Public Safety (L&PS) and the Office of the Attorney General (OAG) concerning special requirements of all Federal, State, municipal laws and regulations and Department of Treasury, State Circulars generally applicable to the activities in which the grantee is engaged in the performance of this grant. Failure to comply with these laws, regulations and State circulars will be grounds for termination of this grant.
3. **Prohibition Against Personal Enrichment:** The Grantee agrees that it will establish safeguards to prohibit employees from using their positions for a purpose that constitutes, or gives the appearance of, personal gain for themselves or others, particularly those with whom they have family, business, or other ties.
4. **Prohibition Against Conflicts of Interests:** The Grantee will establish safeguards to prohibit employees from using their positions for a purpose that constitutes or presents the appearance of personal or organizational conflict of interest.
5. **Anti-Discrimination/Affirmative Action:** The Grantee assures that it will comply, and all of its contractors will comply with the requirements of the State's anti-discrimination and affirmative action laws and regulations, including N.J.A.C. 17:27, applicable provisions of N.J.S.A. 10:5-1, et al., as amended, and all implementing regulations. Failure to comply with these laws, rules, regulations, and State Circular Letters will be grounds for termination of this award.

*SFY21 Body-Worn Camera Grant Program (6/2021)*

Introduced on: August 10, 2021  
Adopted on: August 10, 2021  
Official Resolution#: R20210760

6. **Debarments and Suspensions:** The Grantee understands and agrees to comply with State Executive Order No. 34 (March 17, 1976), and State Circular Letter regarding Debarments, Suspensions & Disqualifications, OMB 93-13-GSA. Grantee will not conduct business with ineligible firms or individuals who are considered debarred, suspended or disqualified.
7. **Minimum Wage/Maximum Hours:** The Grantee agrees to comply with the minimum wage and maximum hours provision of the Federal Fair Labor Standards Act, 29 U.S.C. § 201 et seq., and the New Jersey Prevailing Wage Act, N.J.S.A. 34:11-56.25 et seq.
8. **Financial Management System:** The Grantee agrees to maintain an adequate financial management system in accordance with generally accepted principles of accounting. The Grantee shall maintain accurate and current financial reports, accounting records, internal controls, budget controls, and cash management procedures for receiving, holding and expending grant funds. The Grantee shall maintain accurate and complete disclosure of financial results of each grant in the Detailed Cost Statements (DCS), have procedures to determine allowable costs, and provide source documentation for financial records.
9. **Accounting Records:** The Grantee agrees to enter, maintain and record all grant funds received by the State for this program in accounting records separate from all other fund accounts, including funds derived from other grant awards. Disbursed grant funds shall be available for expenditure by the Grantee in accordance with the provisions of the grant throughout the project period subject to such conditions as OAG may prescribe.
10. **Audit Requirements:** The Grantee agrees to comply with the organizational audit requirements of 2 C.F.R. Part 200.500, et seq., the Government Accountability Office's Government Auditing Standards (Yellow Book), and the State Circular, Single Audit Policy for Recipients of Federal Grants, State Grants and State Aid Payments, 15-08-OMB.  
  
The Grantee understands and agrees that funds may be withheld, or other related requirements may be imposed, if outstanding audit issues (if any) are not satisfactorily and promptly addressed. The Grantee must submit to OAG any copies of any exceptions and/or findings regarding this project as a result of a single audit. The Grantee immediately will report to OAG any changes in its fiscal year.
11. **Allowable Costs:** The Grantee agrees that grant funds will be used only for allowable costs as determined by applicable cost principles specific to the Grantee located at State Circular, Grant Agreements-Agency Contracts, Allowable Costs, 07-05-OMB.
12. **Data Collection and Reporting Requirements:** The Grantee agrees to provide information required for any reporting, data collection, and evaluation conducted by L&PS, OAG and the State of New Jersey. The Grantee also agrees that it will submit timely reports, including programmatic and financial reports, as L&PS may require. If reports are not submitted as required, L&PS may, at its discretion, suspend payments on

*SFY21 Body-Worn Camera Grant Program (6/2021)*

this grant. The State of New Jersey may, at its discretion, withhold payments to the Grantee on this or any grant with other State agencies until the required reports have been submitted.

13. **Budget Revisions/Grant Extensions:** The Grantee agrees to report any Budget Revisions or Grant Extensions as follows:
- a. Deviations in excess of 1% from the approved budget or extensions in the grant period require prior approval via OAG Grant Adjustment Request Form. Grantee should be aware that approved budget revisions may result in the imposition of additional special conditions.
  - b. L&PS may request changes in the scope of services of the Grantee to be performed hereunder. Such changes, which are mutually agreed upon by and between L&PS and the Grantee must be incorporated in written amendments to this grant.
  - c. If the Grantee is making program expenditures or providing grant services at a rate which, in the judgment of L&PS, will result in substantial failure to expend the grant amount or provide grant services, L&PS may so notify the Grantee. If, after consultation, the Grantee is unable to develop to the satisfaction of L&PS a plan to rectify its low level of program expenditures or grant services, L&PS may upon thirty (30) days notice to the Grantee, reduce the grant amount by a sum so that the revised grant amount fairly projects program expenditures over the grant period. This reduction shall take into account the Grantee's fixed costs and shall establish the committed level of services for each program element of grant services at the reduced grant amount. If such a determination is made by L&PS subsequent to the awarding of the grant and the funds have already been received by the Grantee, the reduced amount will be remitted to L&PS.
  - d. The Grantee agrees that should circumstances affecting the grant-funded project change it will immediately contact OAG in writing and advise of such changes; and prior to (or not timely) expending any grant funds other than as contained on the approved budget, it will request and receive prior written approval from OAG via a OAG Grant Adjustment Request Form.
14. **Program Income:** The Grantee agrees that all income earned by the Grantee from grant-supported activities is deemed program income. The Grantee agrees to add program income to funds committed to the program to further eligible program objectives. The use of program income must be shown on the detailed cost statements.
- State Circular, Grant Agreements-Agency Contracts, 07-05-OMB, defines program income to include any interest earned of \$250 or more in a fiscal year on advances of grant funds.
15. **Licensing and Publishing:** The Grantee agrees that L&PS and OAG reserve a royalty-free, non-exclusive and irrevocable license to reproduce, publish, or otherwise use, and authorize others to use: the copyright in any work developed from activities supported by this grant, and any rights of copyright to which a grantee purchases ownership with support. The Grantee agrees that L&PS reserves the right to require the Grantee not to

*SFY21 Body-Worn Camera Grant Program (6/2021)*

publish any work, which right shall not be exercised unreasonably. The Grantee assures that any publication by the Grantee shall include, on the title page, a standard disclaimer of responsibility by L&PS for any opinions or conclusions contained therein.

16. **Records Retention:** Unless otherwise directed by OAG, State or Federal statute, all grant records shall be retained for a period of seven years. This period is extended until otherwise directed if there is any litigation, claim, negotiation, action, or audit in progress and/or audit finding involving grant records started before the end of the seven-year period.
17. **Access to Records:** The Grantee agrees to give the New Jersey Attorney General, L&PS and OAG through any authorized representative, access to and the right to examine all paper and electronic records, books, papers, and documents related to the grant including pertinent accounting records, books, documents, and papers as may be necessary to monitor and audit the Grantee's operations. L&PS reserves the right to have access to all work papers produced in connection with audits made by the Grantee or independent certified public accountants, registered municipal accountants or licensed public accountants hired by the Grantee to perform such audits.
18. **Grant Fund Availability:** Grantee recognizes and agrees that both the initial provision of funding and the continuation of such funding under this grant is expressly dependent upon the availability to L&PS of funds appropriated by the State Legislature from State and/or Federal revenue or such other funding sources as may be applicable. A failure of L&PS to make any payment under this grant or to observe and perform any condition on its part to be performed under the grant as a result of the failure of the Legislature to appropriate shall not in any manner constitute a breach of the agreement by L&PS or an event of default under the agreement and L&PS shall not be held liable for any breach of the agreement because of the absence of available funding appropriations. In addition, future funding shall not be anticipated from L&PS beyond the duration of the award period set forth in the grant agreement and in no event shall the grant agreement be construed as a commitment by L&PS to expend funds beyond the termination date set in the grant agreement.
19. **Subcontracts and Assignments:** The Grantee shall not subcontract any of the work or services covered by this grant, nor shall any interest be assigned or transferred except as may be provided for in this grant or with the express written approval of L&PS. No rights or obligations of the Grantee under this subgrant, in whole or part, may be assigned or subcontracted to another entity for any reason without the prior written approval of OAG and L&PS. The Grantee may not transfer any rights or obligations under this grant pursuant to an acquisition, affiliation, consolidation, merger or other synergy with another entity.
20. **Advances of State Grants:** If applicable, the Grantee agrees that it will deposit advances of State grants in interest bearing accounts.

*SFY21 Body-Worn Camera Grant Program (6/2021)*

Introduced on: August 10, 2021  
 Adopted on: August 10, 2021  
 Official Resolution#: R20210760

21. **Failure to Comply with Award Conditions:** If the Grantee materially fails to comply with the terms of an award, whether stated in a State or Federal statute or regulation, an assurance, general condition, special condition, in a State plan or application, a notice of award, or elsewhere, the Grantee agrees that L&PS may take one or more of the following actions, as appropriate in the circumstances:
- a. Temporarily withhold cash payments pending correction of the deficiency by the Grantee or take more severe enforcement action.
  - b. Disallow all or part of the cost of the activity or action not in compliance.
  - c. Wholly or partly suspend or terminate the current award for the Grantee's program.
  - d. Withhold further awards for the program.
  - e. Request the balance of grant funds to be returned and/or seek reimbursement for funds expended that were not in compliance with the terms and conditions of the grant agreement.
  - f. Take other remedies that may be legally available.
22. **Grant Termination:** When the Grantee has failed to comply with grant award requirements, stipulations, standards, or conditions, the Grantee agrees that L&PS may suspend the grant and withhold further payments; prohibit the Grantee from incurring additional obligations of grant funds pending corrective action by the Grantee; or decide to terminate the grant in accordance with the below paragraph. L&PS shall allow all necessary and proper costs, which the Grantee could not reasonably avoid during the period of suspension, provided they meet State requirements.
23. **L&PS Termination of the Grant:** The Grantee agrees that L&PS may terminate the grant in whole or in part whenever it is determined that the Grantee has failed to comply with the conditions of the grant. L&PS shall notify the Grantee in writing of the determination and the reasons for the termination together with the effective date. Payments made to the Grantee or recoveries by L&PS under the grant terminated for cause shall be in accord with the legal right and liability of the parties.
24. **Mutual Termination of the Grant:** L&PS and the Grantee may terminate the grant in whole, or in part, when both parties agree that the continuation of the project would not produce beneficial results commensurate with the further expenditure of funds. The two parties shall agree upon the termination conditions, including the effective date and in case of partial terminations, the portion to be terminated. The Grantee shall not incur new obligations for the terminated portion after the effective date and shall cancel as many outstanding obligations as possible.
25. **Grant Termination for Convenience:** L&PS may terminate this grant for convenience, upon 60 days written advance notice to the Grantee, for any reason whatsoever, including lack of funding available to L&PS. Upon receipt of a notice of termination for convenience, the Grantee shall cease incurring additional obligations of grant funds. However, L&PS shall allow the Grantee to incur all necessary and proper costs which the Grantee cannot reasonably avoid during the termination process, as long as these costs comply with all program requirements.

*SFY21 Body-Worn Camera Grant Program (6/2021)*

26. **Grant Termination - Notification and Due Process:** If the grant award is terminated for the Grantee's failure to comply with State or Federal statutes, regulations, or terms and conditions of the grant, L&PS will provide notification to the Grantee, including information that the decision may be considered in evaluating future applications.

In taking an enforcement action, L&PS may provide the Grantee an opportunity for such hearing, appeal, or other administrative proceeding to which the Grantee is entitled under any statute or regulation applicable to the action involved.

**High Risk Grantees:** Grantee agrees that under certain instances it may be considered "High Risk":

- a. If L&PS determines that a Grantee:
  - i. Has a history of unsatisfactory performance.
  - ii. Has not filed its quarterly financial reports (Detailed Cost Statements) or Final Grant Narrative in a timely manner.
  - iii. Is not financially stable.
  - iv. Has a financial management system which does not appear adequate according to the General Conditions, or meet the standards expressed according to State Circular Letter, Standard Grant Agreement Form, VIII Financial Management System, 07-05-OMB.
  - v. Has not conformed to terms and conditions of previous awards.
  - vi. Is otherwise not responsible; and L&PS determines that an award will be made; special conditions and/or restrictions shall correspond to the high risk condition and shall be included in the award.
- b. If a Grantee is considered "High Risk," then L&PS may impose additional Special Conditions or restrictions on the Grantee at any time including:
  - i. Issuing payment on a reimbursement basis.
  - ii. Withholding authority to proceed to the next phase until receipt or evidence of acceptable performance within a given funding period.
  - iii. Requiring additional, more detailed financial reports.
  - iv. Requiring additional project monitoring.
  - v. Requiring the Grantee obtain technical or management assistance.
  - vi. Establishing additional prior approvals.
  - vii. Wholly or partly suspending or terminate the current award for the Grantee's program.
  - viii. Withhold further and future awards for the program.
- c. If L&PS decides to impose such special conditions, L&PS will notify the Grantee as soon as possible, in writing, of:
  - i. The nature of the special conditions/restrictions.
  - ii. The reason(s) for imposing the special conditions.
  - iii. The corrective actions that must be taken before the special conditions will be removed by the Department and the time allowed for completing the corrective actions.
  - iv. The method of requesting reconsideration of the conditions/restrictions imposed.

*SFY21 Body-Worn Camera Grant Program (6/2021)*

27. **Corruption of Public Resources Act:** The Grantee understands and agrees that, in compliance with the Corruption of Public Resources Act, N.J.S.A. 2C:27-12, it cannot knowingly misuse State grant funds for an unauthorized purpose, and violations under this act could result in a prison term of up to 20 years, and, under N.J.S.A. 2C:30-8, subject to a fine of up to \$500,000. The Grantee understands and agrees that misuse of award funds may result in a range of penalties, including suspension of current and future funds, suspension or debarment from State grants, recoupment of monies provided under an award and civil and/or criminal penalties, including under the New Jersey False Claims Act, N.J.S.A. 2A: 32C-3.
28. **Prohibition Against State Employee Status:** The Grantee understands and agrees that persons performing services in connection with a grant shall not be considered employees of the State of New Jersey for any purpose, including but not limited to, defense and indemnification for liability claims, workers compensation or unemployment.
29. **Indemnification by non-State Agencies:** The Grantee agrees that it shall be solely responsible for and shall defend, indemnify, keep, save, and hold the State of New Jersey harmless from all claims, loss, liability, expense, or damage resulting from all mental or physical injuries or disabilities, including death, to its employees or recipients of the Grantee's services or to any other persons, or from any damage to any property sustained in connection with the delivery of the Grantee's services that results from any acts or omissions, including negligence or malpractice of any of its officers, directors, employees, agents, servants or independent contractors, or from the Grantee's failure to provide for the safety and protection of its employees, whether or not due to negligence, fault, or default of the Grantee. The Grantee's responsibility shall also include all legal fees and costs that may arise from these actions. The Grantee's liability under this agreement shall continue after the termination of this agreement with respect to any liability, loss, expense, or damage resulting from acts occurring prior to termination.
30. **Release by State Agencies:** The Grantee shall be responsible for, at its own expense defend itself against, and hereby releases the L&PS for any and all suits, claims losses, demands, expenses, or damages of whatsoever kind or nature, arising out of or in connection with any act or omission of the Grantee and its employees, representatives, agents, independent contractors or invitees, related to this grant agreement.



SPECIAL CONDITIONS

1. **Prohibited Use of Funds:** The Grantee certifies that all grant funds will be used exclusively for purposes set forth in the grant application.
2. **Prohibition of Supplanting:** The Grantee agrees that funds made available under this program will be used to supplement but not supplant funds that were, or are, set aside for the same purpose.
3. **Compliance with Program Laws and Regulations:** Grantee will follow all applicable requirements and procedures as required by the Department of Law and Public Safety (L&PS), the Office of the Attorney General (OAG), and as outlined in the notification, award, and other letters sent to the Grantee. Grantee also agrees to follow all applicable requirements and procedures as required by the State of New Jersey.
4. **Attorney General's Directive on Body-Worn Cameras:** Attorney General's Directives on Body-Worn Cameras: The Grantee must comply with Attorney General Law Enforcement Directive No. 2015-12021-5, *Law Enforcement Directive Regarding Police Body-Worn Cameras (BWCs) and Stored BWC Recordings*; Attorney General Law Enforcement Directive 2019-4, *Directive Ensuring the Independent Investigation of Criminal Cases Involving Police Use-of-Force or In-Custody Deaths*; as well as any updates to laws and statutes related to BWCs (i.e., N.J.S.A. 40A:14-118.3-5), and/or new or supplemental guidance to policy, Directives, or Guidelines, concerning BWCs that may occur at the direction and authority of the Attorney General.
5. **Municipal Budget Cap:** In order to be exempt from the municipal budget cap, any monies provided by the municipality must be in the form of matching funds as specified by N.J.S.A. 40A:4-45.3 i. Therefore, the State award and the required fringe benefit match under the Body-Worn Cameras Program are outside the budget cap. However, any additional dollars spent by the municipality in support of the project, including any overmatch, will fall under the Division of Local Government Services budget cap requirements.
6. **Time and Attendance Records:** Grantee must maintain a timekeeping system which provides, at a minimum, records for all personnel charged to the grant as follows: positions (filled with grant funds); rank/title; employee's name; date hired; annual salary; total daily hours worked, and the signatures of the employee and supervisor.
7. **Financial and Performance Reporting:** The Grantee agrees to file timely Detailed Cost Statements (DCS) and payment vouchers within fifteen (15) days after the end of each quarter. The Grantee also agrees to file a timely Final Grant Narrative Report within fifteen (15) days after the end date of the grant period. The Final Grant Narrative Report should describe accomplishments and activities that took place during the grant period. *The Grantee understands and agrees that failure to comply with these filing deadlines may result in a reduction or total loss of the Grantee's award. L&PS may, at its discretion, terminate this or any other BWC grant awards for delinquent reporting.*

8. **Availability of Grant Funds:** The Grantee understands that annual funding for the Body-Worn Cameras Program is uncertain and that funding for each year's grant depends on the continued collection of sufficient program revenue. The Grantee accepts this award on the condition that if sufficient funds are not available, the municipality may not receive its entire State award.
9. **Purchase of Equipment, Consumable Supplies, and Services:** The Grantee agrees that all equipment, consumable supplies, and services purchased or leased with grant funds will be acquired by following standard county and local bidding/procurement procedures, including P.L. 2004, c. 19 (N.J.S.A. 19:44A-20.4 and N.J.S.A. 19:44A-20.5) or state bidding/procurement procedures, including P.L. 2005, c. 51 (N.J.S.A. 19:44A-20.13), when applicable. The Grantee agrees that all equipment purchased under the subaward will be tagged and properly inventoried to reflect use of federal or State funds, as applicable. The Grantee agrees to maintain an inventory list on all consumable supplies purchased with grant funds in the official grant file.
10. **Eligible Expenses:** Recipients of Body-Worn Camera Grant Program funding will be allotted a fixed dollar amount for each camera to be purchased. This dollar amount will exceed the cost of a camera. The excess funding is to be used for ancillary equipment such as clips, chargers, batteries, etc., as well as storage costs. Recipients are not to profit from this funding; ALL funding is to be used towards the cost of implementing the Body-Worn Camera Grant Program. It is the responsibility of the recipient to maintain proof of all expenditures; this documentation will be requested in the event of an audit or site visit.

### CERTIFICATION

I certify that the programs proposed in this application meet all the requirements of the Body-Worn Cameras Grant Program; that all the information presented is correct; and that the applicant will comply with the provisions of this grant program and all other applicable Federal and State laws, regulations, and guidelines.

Passaic County Sheriff's Office

Grant # 21-BWC-342

Awardee

\_\_\_\_\_  
Printed Name

(Mayor, Chief Executive or Village President)

\_\_\_\_\_  
Signature

(Mayor, Chief Executive or Village President)

\_\_\_\_\_  
Date

# County of Passaic Board of County Commissioners

OFFICE OF COUNTY COMMISSIONERS

Director Pasquale "Pat" Lepore  
Deputy Director Bruce James  
Assad R. Akhter  
John W. Bartlett  
Theodore O. Best, Jr.  
Terry Duffy  
Cassandra "Sandi" Lazzara

401 Grand Street  
Paterson, New Jersey 07505  
Tel: 973-881-4402  
Fax: 973-742-3746

Anthony J. De Nova III  
*Administrator*  
Matthew P. Jordan, Esq.  
*County Counsel*  
Louis E. Imhof, III, RMC  
*Clerk Of The Board*



## Public Meeting (Board Meeting)

Date: Aug 10, 2021 - 5:30 PM

Location: County Administration Building  
Webex - 220  
401 Grand Street  
Paterson, NJ 07505

Agenda: RESOLUTION AUTHORIZING PURCHASE OF VARIOUS ITEMS BY THE PASSAIC COUNTY SHERIFF'S OFFICE, PURSUANT TO N.J.S.A. 40A:11-12, ET SEQ., ALL AS NOTED IN THE RESOLUTION.

THIS RESOLUTION WAS REQUESTED BY:

SHERIFF'S DEPT

REVIEWED BY:

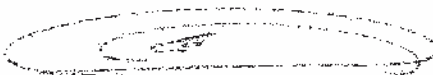
  
Anthony J. De Nova III

COUNTY ADMINISTRATOR

APPROVED AS TO FORM AND LEGALITY:

  
Matthew P. Jordan, Esq.

COUNTY COUNSEL

Law and Public Safety

COMMITTEE NAME

<b>Official Resolution#</b>	<b>R20210761</b>							
Meeting Date	08/10/2021							
Introduced Date	08/10/2021							
Adopted Date	08/10/2021							
Agenda Item	I-45							
CAF #	1-01-25-157-001-213,							
Purchase Req. #	R1-13898; 13875; 13878							
Result	Adopted							
<b>COMMISSIONER</b>	<b>PRES.</b>	<b>ABS.</b>	<b>MOVE</b>	<b>SEC</b>	<b>AYE</b>	<b>NAY</b>	<b>ABST.</b>	<b>RECU.</b>
Lepore	✓				✓			
James	✓		✓		✓			
Akhter	✓			✓	✓			
Bartlett	✓				✓			
Best Jr.	✓				✓			
Duffy	✓				✓			
Lazzara	✓				✓			

PRES.= present ABS.= absent  
 MOVE= moved SEC= seconded  
 AYE= yes NAY= no ABST.= abstain  
 RECU.= recuse

**RESOLUTION AUTHORIZING PURCHASE OF VARIOUS ITEMS BY THE PASSAIC COUNTY SHERIFF'S OFFICE, PURSUANT TO N.J.S.A. 40A:11-12, ET SEQ.**

**WHEREAS**, the County of Passaic (hereafter "County") is a body politic and corporate pursuant to N.J.S.A. 40:18-1 and vested with all rights contained therein; and

**WHEREAS**, pursuant to N.J.S.A. 40:20-1 the Board of County Commissioners of the County of Passaic (hereafter "Board") is vested with managing the property, finances, and affairs of the County; and

**WHEREAS**, the Passaic County Sheriff's Office (hereafter "PCSO") has requested the purchase of various goods and services from qualified vendors for use in furtherance of its administrative objectives; and

**WHEREAS**, said goods and services are being procured through State Contracts as permitted by N.J.S.A. 40A:11-12 et seq. and as specified below; and

**WHEREAS**, the Board is desirous of approving said purchases in accordance with the terms of the applicable contracts and authorizing the Purchasing Agent to issue the appropriate Purchase Orders; and

**WHEREAS**, this matter was discussed by the Law and Public Safety Committee at its August 3, 2021 meeting and is being recommended to the Board for approval; and

**WHEREAS**, funds are available in the accounts outlined below, or any other account that may be deemed appropriate by the Chief Financial Officer or his designee, and the availability of funds has been contingently certified by the Chief Financial Officer subject to sufficient funds being appropriated by the Board in the 2021 and/or subsequent years' County budget(s), which is attached to and made part of this Resolution; and

**NOW, THEREFORE, LET IT BE RESOLVED**, pursuant to N.J.S.A. 40A:11-12, et seq. that the Board of County Commissioners of the County of Passaic hereby authorizes the purchase of the following goods and/or services in accordance with the terms of the applicable State Contracts:

Description:	Service and Maintenance on CAD/RMS Computer aided dispatch records management system for the period from September 16, 2021 through September 15, 2022
Using Agency:	PCSO
Purchase Price:	\$186,691.90
Vendor:	Insight Public Sector SLED
Authority:	State Contract
Master P.O.:	20-TELE-01512
Account(s):	1-01-25-157-001-213

Description:	Two (2) – 2022 Chevrolet Tahoes
Using Agency:	PCSO
Purchase Price:	\$75,915.94
Vendor:	Hertrich Fleet Services, Inc.
Authority:	State Contract
Master P.O.:	21-FLEET-01483
Account(s):	T-13-56-860-000-081

Description:	Tazer Equipment and Supplies
Using Agency:	PCSO
Purchase Price:	\$22,228.00
Vendor:	Axon Enterprise, Inc.
Authority:	State Contract
Master P.O.:	17-FLEET-00738
Account(s):	1-01-25-157-001-203

**LET IT BE FURTHER RESOLVED**, that the Purchasing Agent and all other necessary officers and employees be and hereby are authorized and directed to take such further actions and sign such documents as are necessary to effectuate the purpose of this resolution, including but not limited to issuance of appropriate Purchase Orders.

LSP

August 10, 2021



INSIGHT PUBLIC SECTOR SLED  
6820 S HARL AVE  
TEMPE AZ 85283-4318  
Tel: 800-467-4448

**SOLD-TO PARTY** 10333653  
Passaic County Sheriff's Dept

Quotation	
Quotation Number	: 223920532
Document Date	: 20-Jul-21
PO Number	:
PO Release	:
Sales Rep	: Dennis Westerfield
Email	: <a href="mailto:dennis.westerfield@insight.com">dennis.westerfield@insight.com</a>
Telephone	: 480-225-4618

**We deliver according to the following terms:**

Payment Terms	Net 30 days
Ship Via	FOB DESTINATION
Terms of Delivery	Insight Assigned Carrier / Ground
Currency	USD

Material	Qty	Description	Unit Price	Extended Price
<b>Header Detail</b>				
CSI InfoCAD Server	1	CSI InfoShare InfoCAD Server Base System (Clustering Edition)	\$36,879.21	\$36,879.21
CSI InfoCAD MDT	1	CSI AVL plug in for MDT	\$5,429.56	\$5,429.56
CSI InfoCAD MDT	1	CSI InfoCAD Workstations - Standby / Backup	\$8,353.16	\$8,353.16
CSI InfoCAD MDT	1	CSI InfoCAD MDT Application	\$8,687.29	\$8,687.29
CSI InfoRMS	1	CSI InfoRMS Module with Sub-Module (Package)	\$50,453.10	\$50,453.10
CSI Interface	1	CSI Interface - Sagem Morpho LiveScan	\$3,341.26	\$3,341.26
CSI Installation	1	CSI Installation Services for Server & Dispatcher Software (CAD, RMS, Personnel)	\$3,341.26	\$3,341.26
CSI Training	1	CSI Training Services	\$8,019.04	\$8,019.04
CSI Data Conversion	1	CSI Data Conversion Services - LawSoft	\$5,680.15	\$5,680.15
CSI Internal Affairs	1	CSI Internal Affairs Module	\$8,353.16	\$8,353.16
CSI Interface	1	CSI Interface with GTL Inmate Management System	\$5,680.15	\$5,680.15

Introduced on: August 10, 2021  
Adopted on: August 10, 2021  
Official Resolution#: R20210761



INSIGHT PUBLIC SECTOR SLED  
 6820 S HARL AVE  
 TEMPE AZ 85283-4318  
 Tel: 800-467-4448

Other	1	CSI Warrants Module	\$5,011.90	\$5,011.90
Installation	1	CSI Beast Interface	\$0.00	\$0.00
Maintenance	1	CSI InfoShare Solution Annual Maintenance	\$37,462.66	\$37,462.66
		NJ Custom Agreement 20-M0003-CSI01, Tier 1		
		Insight cost \$184,386.25, mark up 1.25%		
		Coverage dates 9/16/2021- 9/15/2022		
			<b>Total</b>	<b>\$186,691.90</b>

Contract : State of NJ Software license & related services, 20-TELE-01512/T3121

Thank you for considering Insight.

Please include quote number on your order to ensure prompt processing. Contact us with any questions or for additional information about Insight's complete IT solution offering. Again, thank you for considering Insight!

Sincerely,  
 Dennis Westerfield  
 Account Executive

[http://www.insight.com/en\\_US/help/terms-of-sale-products:ps.html](http://www.insight.com/en_US/help/terms-of-sale-products:ps.html)

**COUNTY OF PASSAIC**  
 SHERIFF'S DEPT, ATTN: SHANNAN  
 CO OF PASSAIC, (Q)973-247-3312  
 435 HAMBURG TURNPIKE  
 WAYNE, NJ 07470

REQUISITION	
NO.	R1-13898

SHIP TO	PASSAIC COUNTY SHERIFFS DEPT 435 HAMBURG TURNPIKE ATTN: JAMES SHAY WAYNE, NJ 07470
VENDOR	VENDOR #: 05333 INSIGHT 6820 SOUTH HARL AVENUE TEMPE, AZ 85283

ORDER DATE: 07/29/21  
 DELIVERY DATE:  
 STATE CONTRACT: 20-TELE-01512  
 F.O.B. TERMS:

QTY/UNIT	DESCRIPTION	ACCOUNT NO.	UNIT PRICE	TOTAL COST
1.00	QUOTE# 223920532 DATED: 7/20/21  SERVICE & MAINTENANCE ON OUR CAD/RMS COMPUTER AIDED DISPATCH RECORDS MANAGEMENT SYSTEM FOR LAW ENFORCEMENT.  CONTRACT PERIOD: 9/16/21 - 9/15/22  AS PER STATE CONTRACT # 20-TELE-01512  PENDING RESOLUTION	1-01-25-157-001-213	186,691.9000	186,691.90
			TOTAL	186,691.90

Introduced on: August 10, 2021  
 Adopted on: August 10, 2021  
 Official Resolution#: R20210761

REQUESTING DEPARTMENT

DATE



# HERTRICH FLEET SERVICES, INC

1427 Bay Road Milford, DE 19963

Ford - Chevrolet - Dodge - Jeep  
Lincoln - Honda - Buick - GMC - Toyota - Nissan

(800) 698-9825

(302) 422-3300

Fax: (302) 839-0555

**NJ State Contract #21-FLEET-01483 (T2776)**

**Item #1, Line #21, Section 11: Tahoe Special Service Vehicle (SSV), 4-Door, w/ Gasoline Engine (Non- Police Pursuit) 4WD**

Mike Wright, Government Sales Manager

Hertrich Fleet Services Inc

1427 Bay Rd

Milford, DE 19963

Phone: (800) 698-9825

Fax: (302) 839-0555

Email: mwright@hertrichfleet.com

**QUOTE FOR: PASSAIC COUNTY SHERIFFS OFFICE**

#07272021-02

## 2022 Chevrolet Tahoe 4WD 4dr SSV Non-Pursuit CK15706

### SELECTED OPTIONS(included in Base Contract Price):

<u>Code</u>	<u>Description</u>
ZW7	SUSPENSION PACKAGE, Premium Smooth Ride
NE1	NORTHEAST EMISSIONS
L84	ENGINE, 5.3L ECOTEC3 V8 with Dynamic Fuel Management
MQC	TRANSMISSION, 10-speed automatic electronically controlled with overdrive
C6H	GVWR, 7500 lbs. (3402 kg)
GU5	REAR AXLE, 3.23 RATIO
1FL	COMMERCIAL PREFERRED EQUIPMENT GROUP
PZX	WHEELS, 18" x 8.5" (45.7 cm x 21.6 cm) Bright Silver painted aluminum
QDF	TIRES, 265/65R18SL all-season, black wall
AZ3	SEATS, FRONT 40/20/40 split-bench
H1T	JET BLACK, CLOTH SEAT TRIM
IOR	AUDIO SYSTEM, Chevrolet Infotainment 3 system, 8" diagonal color touchscreen AM/FM stereo. Additional features for compatible phones include: Bluetooth audio streaming for 2 active devices
5W4	IDENTIFIER FOR SPECIAL SERVICE vehicle includes (K47) heavy-duty air filter, (KX4) 250 amp high output alternator, (K6K) 760 cold-cranking amps auxiliary battery, electrical power and vehicle signals for customer connection located at the center front floor, auxiliary battery circuit for customer connection located in the rear cargo area, (RC1) front skid plate, SEO (5J3) Surveillance Mode interior lighting calibration, SEO (UT7) blunt cut cargo area and blunt cut console area ground wires, (V53) delete luggage rack side rails, (ATD) third row seat delete and (NP0) active single-speed transfer case.
K6K	BATTERY, AUXILIARY, 760 cold-cranking amps with 70 amp hour rating
K3W	BATTERY, 900 cold-cranking amps with 95 amp hour rating
KX4	ALTERNATOR, 220 amps
RC1	SKID PLATE, FRONT
	CAPLESS FUEL FILL
WUA	FASCIA, FRONT HIGH-APPROACH ANGLE
V53	LUGGAGE RACK SIDE RAILS, DELETE
	EXTERIOR ORNAMENTATION DELETE
VK3	LICENSE PLATE FRONT mounting package
UDA	ONSTAR DEACTIVATED (does not delete Bluetooth)

Introduced on: August 10, 2021

Adopted on: August 10, 2021

Official Resolution#: R20210761 "A Member of the HERTRICH Family of Automobile Dealerships"

# HERTRICH FLEET SERVICES, INC

1427 Bay Road Milford, DE 19963

Ford - Chevrolet - Dodge - Jeep  
Lincoln - Honda - Buick - GMC - Toyota - Nissan

(800) 698-9825

(302) 422-3300

Fax: (302) 839-0555

**SELECTED OPTIONS (included in Base Contract Price):**

Code	Description
ATD	SEAT DELETE, THIRD ROW passenger (Deletes rear storage compartment.)
VZ2	SPEEDOMETER CALIBRATION
	INSTRUMENTATION, analog with certified 140 mph speedometer
AX2	KEY, UNIQUE
	THEFT-DETERRENT SYSTEM, vehicle, PASS-Key III
	POWER SUPPLY, 50-amp, power supply
	POWER SUPPLY, 100-amp, auxiliary battery, rear electrical center
	POWER SUPPLY, 120-AMP, (4) 30-amp circuit
	SEAT BELTS, 3-point, all seating positions
	LANE KEEP ASSIST DELETE
	PROTECTED IDLE
5J3	CALIBRATION, SURVEILLANCE MODE interior lighting
5J9	CALIBRATION TAILLAMP FLASHER, RED/WHITE
5Y1	FRONT CENTER SEAT (20% SEAT) DELETE
UT7	GROUND WIRES, blunt cut cargo area and blunt cut console area

BASE CONTRACT PRICE: \$35315.00

**EXTERIOR COLOR:**

GBA BLACK \$0.00

**ADDITIONAL OPTIONS:**

Code	Description	Price
RD4	WHEELS, 20" X 9" (50.8 CM X 22.9 CM) PAINTED ALUMINUM with machine face and Argent Metallic pockets	\$728.00
A50	SEATS, FRONT BUCKET (When ordered with (5W4) Special Service Vehicle, Requires (PQA) 1FL Safety Package. Includes (D07) floor console.)	\$318.50
PQA	1FL SAFETY PACKAGE includes (UEU) Forward Collision Alert, (UHX) Lane Keep Assist with Lane Departure Warning, (UHY) Automatic Emergency Braking, (UKJ) Front Pedestrian Braking and (UE4) Following Distance Indicator (Requires (5W4) Special Service Vehicle. Not available with (DRZ) Rear Camera Mirror.)	\$359.45
NHT	MAX TRAILERING PACKAGE includes (ZL6) Advanced Trailering Package and (V03) extra capacity cooling system (When ordered with (5W4) Special Service Vehicle, also includes (NQH) 2-speed active transfer case on 4WD models.)	\$318.50
ZL6	ADVANCED TRAILERING PACKAGE includes (JL1) trailer brake controller and (UID) Advanced Trailering System (Included and only available with (NHT) Max Trailering Package. Does not include (PZ8) Hitch Guidance with Hitch View. Does not include (UID) Advanced Trailering System software.)	\$0.00
V76	RECOVERY HOOKS, 2 FRONT, frame-mounted, Black approach front fascia, rear fascia and tailgate applique. Black parts will be lift gate handle, door handles, D-pillar applique, rear spoiler, mirrors, ultrasonic park assist sensors and OnStar antenna. (Requires (TGK) Special Paint and (01U) Special Paint.)	\$45.50
B30	FLOOR COVERING, COLOR-KEYED CARPETING in occupant area, first and second row, removable. Carpeting is only in occupant area. Horizontal surface of cargo area is covered in black vinyl.	\$177.45
B58	FLOOR MATS, COLOR-KEYED CARPETED FIRST AND SECOND ROW, removable (Required and only available with (B30) color-keyed carpeting floor covering.)	\$72.80

Introduced on: August 10, 2021

Adopted on: August 10, 2021

Official Resolution#: R20210761 "A Member of the HERTRICH Family of Automobile Dealerships"

# HERTRICH FLEET SERVICES, INC

1427 Bay Road Milford, DE 19963

Ford - Chevrolet - Dodge - Jeep  
Lincoln - Honda - Buick - GMC - Toyota - Nissan

(800) 698-9825

(302) 422-3300

Fax: (302) 839-0555

## ADDITIONAL OPTIONS :

<u>Code</u>	<u>Description</u>	<u>Price</u>
BTV	REMOTE START	\$273.00
6J3	WIRING, GRILLE LAMPS AND SIREN SPEAKERS (Requires VPV Ship Thru Charge)	\$83.72
6J4	WIRING, HORN AND SIREN CIRCUIT (Requires VPV Ship Thru Charge)	\$50.05
6J7	FLASHER SYSTEM, HEADLAMP AND TAILLAMP, DRL compatible with control wire (Includes SEO (5J9) tail lamp flasher calibration, Red/White and SEO (5LO) tail lamp flasher calibration, Red/Red.) (Requires VPV Ship Thru Charge)	\$45.50
9G8	HEADLAMPS, DAYTIME RUNNING LAMPS and automatic headlamp control delete deletes standard Daytime Running Lamps and automatic headlamp control features	\$45.50
VPV	SHIP THRU, Produced in Arlington Assembly and Shipped to Kerr Industries and onto Arlington Assembly, Required with options 6C7, 6N5, 6N6, 7X2, 7X3, T53, UN9, 6J3, 6J4, WX7, 6JG	\$125.00
<b>TOTAL W/OPTIONS:</b>		<u>\$37957.97</u>

ORDER BANK OPENS 8/12/2021

Introduced on: August 10, 2021

Adopted on: August 10, 2021

Official Resolution#: R20210761 "A Member of the HERTRICH Family of Automobile Dealerships"

COUNTY OF PASSAIC  
 SHERIFF'S DEPT, ATTN: SHANNAN  
 CO OF PASSAIC, (Q) 973-247-3312  
 435 HAMBURG TURNPIKE  
 WAYNE, NJ 07470

REQUISITION	
NO.	R1-13875

SHIP TO	PASSAIC COUNTY SHERIFFS DEPT 65 COLOMBIA AVE ATTN: SCOTT STRACCO PATERSON, NJ 07503
VENDOR	VENDOR #: 09713 HERTRICH FLEET SERVICES, INC. 1427 BAY ROAD ATTN: MIKE WRIGHT MILFORD, DE 19963

ORDER DATE: 07/28/21  
 DELIVERY DATE:  
 STATE CONTRACT:  
 F.O.B. TERMS:

QTY/UNIT	DESCRIPTION	ACCOUNT NO.	UNIT PRICE	TOTAL COST
2.00 EA	2022 CHEVROLET TAHOE 4WD 4DR SSV (NON POLICE PURSUIT) US4 & WARDEN  EXTERIOR COLOR GSA BLACK ALL OPTIONS AS NOTED IN QUOTE # 07272021-02  AS PER STATE CONTRACT # 21-FLEET-01483  PENDING RESOLUTION	T-13-56-860-000-801	37,957.9700	75,915.94
			TOTAL	75,915.94

Introduced on: August 10, 2021  
 Adopted on: August 10, 2021  
 Official Resolution#: R20210761

REQUESTING DEPARTMENT

DATE

Q-325634-44399.8898P

Issued: 07/22/2021

Account Number: 198645

Payment Terms: N30

Delivery Method: Fedex - Ground

Axon Enterprise, Inc.  
 17800 N 85th St.  
 Scottsdale, Arizona 85255  
 United States  
 VAT: 86-0741227  
 Domestic: (800) 978-2737  
 International: +1.800.978.2737



Introduced on: August 10, 2021  
 Adopted on: August 10, 2021  
 Official Resolution#: R20210761

<b>SALES REPRESENTATIVE</b>	<b>PRIMARY CONTACT</b>
Bill Parrish Phone: (973) 881-4631 Email: parrishb@axon.com Fax:	Phone: (973) 881-4631 Email: ssiekis@pcsheriff.org Fax:

<b>BILL TO</b>	<b>BILL TO</b>
Delivery: Invoice-435 Hamburg Tpke 435 Hamburg Tpke Wayne, NJ 07470-2067 USA Email:	Passaic County Sheriff's Office- NJ 435 Hamburg Tpke Wayne, NJ 07470-2067 USA Email:

Average Savings Per Year	\$0.00
<b>TOTAL SAVINGS</b>	\$0.00

Program Length	59.5806 Months
<b>TOTAL COST</b>	\$27,228.00
	\$27,228.00

<b>PAYMENT PLAN</b>
PAID IN ADVANCE

<b>BILLED ON FULFILLMENT</b>
PAID IN ADVANCE
None
As Fulfilled
\$22,228.00

Q-325634-44399.8898P

Quote Details

**Bundle Summary**

**Individual Items USD**

Item	Description	Quantity	Unit Price	Total Price
Other	25 FT NON-CONDUCTIVE TRAINING SMART CARTRIDGE, X2	350	\$40.44	\$38.70
Other	SUIT, ENHANCED SIM, MODEL II	1	\$765.99	\$733.00
Other	25 FT SMART CARTRIDGE, X2 NS	200	\$41.54	\$39.75
				\$733.00
				\$7,950.00

Tax is estimated based on rates applicable at date of quote and subject to change at time of invoicing. If a tax exemption certificate should be applied, please submit prior to invoicing.

*Exemption for Ut. Steakis + steel equipment*  
*17 Fleet - 80738*  
*Check 1 Year S budget*  
*#26070*

# Standard Terms and Conditions

Axon Enterprise Inc. Sales Terms and Conditions

Axon Master Services and Purchasing Agreement:

This Quote is limited to and conditional upon your acceptance of the provisions set forth herein and Axon's Master Services and Purchasing Agreement (posted at [www.axon.com/legal/sales-terms-and-conditions](http://www.axon.com/legal/sales-terms-and-conditions)), as well as the attached Statement of Work (SOW) for Axon Fleet and/or Axon Interview Room purchase, if applicable. In the event you and Axon have entered into a prior agreement to govern all future purchases, that agreement shall govern to the extent it includes the products and services being purchased and does not conflict with the Axon Customer Experience Improvement Program Appendix as described below.

## ACEIP:

The Axon Customer Experience Improvement Program Appendix, which includes the sharing of de-identified segments of Agency Content with Axon to develop new products and improve your product experience (posted at [www.axon.com/legal/sales-terms-and-conditions](http://www.axon.com/legal/sales-terms-and-conditions)), is incorporated herein by reference. By signing below, you agree to the terms of the Axon Customer Experience Improvement Program.

## Acceptance of Terms:

Any purchase order issued in response to this Quote is subject solely to the above referenced terms and conditions. By signing below, you represent that you are lawfully able to enter into contracts. If you are signing on behalf of an entity (including but not limited to the company, municipality, or government agency for whom you work), you represent to Axon that you have legal authority to bind that entity. If you do not have this authority, please do not sign this Quote.

Q-325634-44399.772BP

L. Scott Slick #400

Signature

7/22/2021

7/22/2021

Date Signed

Introduced on: August 10, 2021  
Adopted on: August 10, 2021  
Official Resolution#: R20210761



Q-325634-44399.772BP

Issued: 07/22/2021

Quote Expiration: 10/25/2021

Account Number: 1926-45

Payment Terms: N30

Delivery Method: Fedex - Ground

PRIMARY CONTACT

Bill Parrish  
 Phone: (973) 881-4631  
 Email: spstleis@pcsheriff.org  
 Fax:

SALES REPRESENTATIVE

Bill Parrish  
 Phone:  
 Email: parrishb@axon.com  
 Fax:

BILL TO

Passaic County Sheriff's Office- NJ  
 435 Hamburg Tpke  
 Wayne, NJ 07470-2067  
 USA  
 Email:

SHIP TO

Delivery: Invoice-435 Hamburg Tpke  
 435 Hamburg Tpke  
 Wayne, NJ 07470-2067  
 USA

Axon Enterprise, Inc.  
 17800 N 85th St.  
 Scottsdale, Arizona 85255  
 United States  
 VAT: 86-0741227  
 Domestic: (800) 978-2737  
 International: +1.800.978.2737

Average Savings Per Year \$0.00

TOTAL SAVINGS \$0.00

Program Length 59.5806 Months

TOTAL COST \$22,228.00

\$22,228.00

AMOUNT DUE

INVOICE DATE

PAYMENT PLAN

PLAN NAME

AMOUNT DUE

INVOICE DATE

BILLED ON FULFILLMENT

PLAN NAME

None

As Fulfilled

\$22,228.00

Introduced on: August 10, 2021  
 Adopted on: August 10, 2021  
 Official Resolution#: R20210761

Q-325634-44399.772BP

Quote Details

Bundled Summary		Average Cost Per Year		Cost Per User Per Month	
Item	Description	QTY	Average Cost Per Year	Cost Per User Per Month	
<b>Individual Items USD</b>					
Category	Item	Description			Requested Ship Date
Other	22157	25 FT NON-CONDUCTIVE TRAINING SMART CARTRIDGE, X2			10/13/2021
Other	44650	SUIT, ENHANCED SIM, MODEL II			10/13/2021
Other	22185	25 FT SMART CARTRIDGE, X2 NS			10/13/2021

Tax is estimated based on rates applicable at date of quote and subject to change at time of invoicing. If a tax exemption certificate should be applied, please submit prior to invoicing.

Introduced on: August 10, 2021  
 Adopted on: August 10, 2021  
 Official Resolution#: R20210761

Q-325534-44399.772BP

# Standard Terms and Conditions

Axon Enterprise Inc. Sales Terms and Conditions

Axon Master Services and Purchasing Agreement:

This Quote is limited to and conditional upon your acceptance of the provisions set forth herein and Axon's Master Services and Purchasing Agreement (posted at [www.axon.com/legal-sales-terms-and-conditions](http://www.axon.com/legal-sales-terms-and-conditions)), as well as the attached Statement of Work (SOW) for Axon Fleet and/or Axon Interview Room purchase, if applicable. In the event you and Axon have entered into a prior agreement to govern all future purchases, that agreement shall govern to the extent it includes the products and services being purchased and does not conflict with the Axon Customer Experience Improvement Program Appendix as described below.

## ACCEPT:

The Axon Customer Experience Improvement Program Appendix, which includes the sharing of de-identified segments of Agency Content with Axon to develop new products and improve your product experience (posted at [www.axon.com/legal-sales-terms-and-conditions](http://www.axon.com/legal-sales-terms-and-conditions)), is incorporated herein by reference. By signing below, you agree to the terms of the Axon Customer Experience Improvement Program.

## Acceptance of Terms:

Any purchase order issued in response to this Quote is subject solely to the above referenced terms and conditions. By signing below, you represent that you are lawfully able to enter into contracts. If you are signing on behalf of an entity (including but not limited to the company, municipality, or government agency for whom you work), you represent to Axon that you have legal authority to bind that entity. If you do not have this authority, please do not sign this Quote.

COUNTY OF PASSAIC  
 SHERIFF'S DEPT, ATTN: SHANNAN  
 CO OF PASSAIC, (Q)973-247-3312  
 435 HAMBURG TURNPIKE  
 WAYNE, NJ 07470

REQUISITION	
NO.	R1-13878

SHIP TO	PASSAIC COUNTY SHERIFFS DEPT 435 HAMBURG TURNPIKE ATTN: SHANNAN THOMAS WAYNE, NJ 07470
VENDOR	VENDOR #: 12318 AXON ENTERPRISE, INC. 17800 NORTH 85TH STREET SCOTTSDALE, AZ 85255-9306

ORDER DATE: 07/28/21  
 DELIVERY DATE:  
 STATE CONTRACT: 17-FLEET-00738  
 F.O.B. TERMS:

QTY/UNIT	DESCRIPTION	ACCOUNT NO.	UNIT PRICE	TOTAL COST
350.00 EA	25 FT NON CONDUCTIVE TRAINING SMART CARTRIDGE, X2 Catalog #: 22157	1-01-25-157-001-203	38.7000	13,545.00
1.00 EA	SUIT ENHANCED SIM, MODEL II Catalog #: 44550	1-01-25-157-001-203	733.0000	733.00
200.00 EA	25FT SMART CARTRIDGE X2 NS AS PER QUOTE # Q325634-44399.8898P DATED 7/22/21 ACCT. # 198645  AS PER STATE CONTRACT # 17-FLEET-00738  PENDING RESOLUTION Catalog #: 22185	1-01-25-157-001-203	39.7500	7,950.00
			TOTAL	22,228.00

Introduced on: August 10, 2021  
 Adopted on: August 10, 2021  
 Official Resolution#: R20210761

REQUESTING DEPARTMENT \_\_\_\_\_ DATE \_\_\_\_\_

CERTIFICATION OF AVAILABLE FUNDS

THIS IS TO CERTIFY THAT FUNDS ARE AVAILABLE AS FOLLOWS:

AMOUNT: \$284,835.84

APPROPRIATION: T-13-56-860-000-801 - \$75,915.94  
1-01-25-157-001-213 - \$186,691.90  
1-01-25-157-001-203 - \$22,228.00

PURPOSE: Authorize the purchase of various items by the Passaic  
County Sheriff's Office.



Richard Cahill, Director of Finance

DATED: August 10, 2021

# County of Passaic Board of County Commissioners

OFFICE OF COUNTY COMMISSIONERS

Director Pasquale "Pat" Lepore  
Deputy Director Bruce James  
Assad R. Akhter  
John W. Bartlett  
Theodore O. Best, Jr.  
Terry Duffy  
Cassandra "Sandi" Lazzara

401 Grand Street  
Paterson, New Jersey 07505  
Tel: 973-881-4402  
Fax: 973-742-3746

Anthony J. De Nova III  
*Administrator*  
Matthew P. Jordan, Esq.  
*County Counsel*  
Louis E. Imhof, III, RMC  
*Clerk Of The Board*



## Public Meeting (Board Meeting)

Date: Aug 10, 2021 - 5:30 PM

Location: County Administration Building  
Webex - 220  
401 Grand Street  
Paterson, NJ 07505

Agenda: RESOLUTION AUTHORIZING THE PASSAIC COUNTY PROSECUTOR'S OFFICE TO APPLY FOR 2021 STATE BODY ARMOR REPLACEMENT FUND GRANT PROGRAM, ALL AS NOTED IN THE RESOLUTION.

THIS RESOLUTION WAS REQUESTED BY:  
PROSECUTOR'S OFFICE

REVIEWED BY:

Anthony J. De Nova III  
COUNTY ADMINISTRATOR

APPROVED AS TO FORM AND LEGALITY:

Matthew P. Jordan, Esq.  
COUNTY COUNSEL

Law and Public Safety  
COMMITTEE NAME

<b>Official Resolution#</b>	<b>R20210762</b>							
Meeting Date	08/10/2021							
Introduced Date	08/10/2021							
Adopted Date	08/10/2021							
Agenda Item	I-46							
CAF #								
Purchase Req. #								
Result	Adopted							
<b>COMMISSIONER</b>	<b>PRES.</b>	<b>ABS.</b>	<b>MOVE</b>	<b>SEC</b>	<b>AYE</b>	<b>NAY</b>	<b>ABST.</b>	<b>RECU.</b>
Lepore	✓				✓			
James	✓		✓		✓			
Akhter	✓			✓	✓			
Bartlett	✓				✓			
Best Jr.	✓				✓			
Duffy	✓				✓			
Lazzara	✓				✓			

PRES.= present ABS.= absent  
MOVE= moved SEC= seconded  
AYE= yes NAY= no ABST.= abstain  
RECU.= recuse

**Dated: August 11, 2021**

**RESOLUTION AUTHORIZING THE PASSAIC COUNTY PROSECUTOR'S OFFICE TO APPLY FOR 2021 STATE BODY ARMOR REPLACEMENT FUND GRANT PROGRAM**

**WHEREAS**, the County of Passaic (hereinafter the "County") is a body politic and corporate pursuant to N.J.S.A. 40:18-1 and vested with all rights contained therein; and

**WHEREAS**, pursuant to N.J.S.A. 40:20-1 the Board of County Commissioner of the County of Passaic (hereinafter the "Board") is vested with managing the property, finances, and affairs of the County; and

**WHEREAS**, the Passaic County Prosecutor's Office (hereinafter "PCPO") seeks permission to apply for the 2021 State Body Armor Replacement Fund Grant program;

**WHEREAS**, the amount of the grant award, if any, is yet unknown; and

**WHEREAS**, the PCPO will use any funds received through the 2021 State Body Armor Replacement Fund Grant program to purchase bullet proof vests for the PCPO Investigators; and

**WHEREAS**, this matter was discussed by the Law and Public Safety Committee at its August 3, 2021 meeting and is being recommended to the Board for approval.

**NOW, THEREFORE, LET IT BE RESOLVED**, that the Board of County Commissioners of the County of Passaic hereby authorizes the Passaic County Prosecutor's Office to apply for the 2021 State Body Armor Replacement Fund Grant program, which will be used for the purchase of bullet proof vests for the Passaic County Prosecutor's Office Investigators.

**LET IT BE FURTHER RESOLVED**, that the Clerk of the Board, County Counsel, County Administrator, and Director of the Board of County Commissioners are authorized to execute an agreement and take any other steps necessary to carry out the purpose of this resolution.

I.SP

August 10, 2021

# County of Passaic Board of County Commissioners

OFFICE OF COUNTY COMMISSIONERS

Director Pasquale "Pat" Lepore  
Deputy Director Bruce James  
Assad R. Akhter  
John W. Bartlett  
Theodore O. Best, Jr.  
Terry Duffy  
Cassandra "Sandi" Lazzara

401 Grand Street  
Paterson, New Jersey 07505  
Tel: 973-881-4402  
Fax: 973-742-3746

Anthony J. De Nova III  
*Administrator*  
Matthew P. Jordan, Esq.  
*County Counsel*  
Louis E. Imhof, III, RMC  
*Clerk Of The Board*



## Public Meeting (Board Meeting)

Date: Aug 10, 2021 - 5:30 PM

Location: County Administration Building  
Webex - 220  
401 Grand Street  
Paterson, NJ 07505

Agenda: RESOLUTION AUTHORIZING PURCHASE OF COPIER MAINTENANCE SERVICES BY THE PASSAIC COUNTY PROSECUTOR'S OFFICE, PURSUANT TO N.J.S.A. 40A:11-12 ET SEQ., ALL AS NOTED IN THE RESOLUTION.

THIS RESOLUTION WAS REQUESTED BY:  
PROSECUTOR'S OFFICE

REVIEWED BY:

Anthony J. De Nova III  
COUNTY ADMINISTRATOR

APPROVED AS TO FORM AND LEGALITY:

Matthew P. Jordan, Esq.  
COUNTY COUNSEL

Law and Public Safety  
COMMITTEE NAME

<b>Official Resolution#</b>	<b>R20210763</b>							
Meeting Date	08/10/2021							
Introduced Date	08/10/2021							
Adopted Date	08/10/2021							
Agenda Item	I-47							
CAF #	1-01-20-109-001-219							
Purchase Req. #								
Result	Adopted							
<b>COMMISSIONER</b>	<b>PRES.</b>	<b>ABS.</b>	<b>MOVE</b>	<b>SEC</b>	<b>AYE</b>	<b>NAY</b>	<b>ABST.</b>	<b>RECU.</b>
Lepore	✓				✓			
James	✓		✓		✓			
Akhter	✓			✓	✓			
Bartlett	✓				✓			
Best Jr.	✓				✓			
Duffy	✓				✓			
Lazzara	✓				✓			

PRES.= present ABS.= absent  
MOVE= moved SEC= seconded  
AYE= yes NAY= no ABST.= abstain  
RECU.= recuse

Dated: August 11, 2021



**RESOLUTION AUTHORIZING PURCHASE OF COPIER MAINTENANCE SERVICES  
BY THE PASSAIC COUNTY PROSECUTOR'S OFFICE,  
PURSUANT TO N.J.S.A. 40A:11-12 ET SEQ.**

**WHEREAS**, the County of Passaic (hereafter "County") is a body politic and corporate pursuant to N.J.S.A. 40:18-1 and vested with all rights contained therein; and

**WHEREAS**, pursuant to N.J.S.A. 40:20-1 the Board of County Commissioners of the County of Passaic (hereafter "Board") is vested with managing the property, finances, and affairs of the County; and

**WHEREAS**, the Passaic County Prosecutor's Office (hereafter "PCPO") has requested the purchase of certain services from a qualified vendor for use in furtherance of its administrative objectives; and

**WHEREAS**, said services are being procured through State Contract as permitted N.J.S.A. 40A:11-12 et seq. and as specified below; and

**WHEREAS**, the Board is desirous of approving said purchase in accordance with the terms of the applicable contracts and authorizing the Purchasing Agent to issue the appropriate Purchase Orders; and

**WHEREAS**, this matter has been reviewed by the Law and Public Safety Committee at its August 3, 2021, meeting and is being recommended to the Board of for approval; and

**WHEREAS**, funds are available in Account No. 1-01-20-109-001-219 or any other account that may be deemed appropriate by the Chief Financial Officer or his designee, and the availability of funds has been contingently certified by the Chief Financial Officer subject to sufficient funds being appropriated by the Board in the 2021 and/or subsequent years' County budget(s), which is attached to and made part of this Resolution; and

**NOW, THEREFORE, LET IT BE RESOLVED**, pursuant to N.J.S.A. 40A:11-12 et seq. by the Board of County Commissioners of the County of Passaic that it hereby authorizes the purchase of the following services in accordance with the terms of the applicable State Contract:

Description:	Copier Maintenance Service for the Remainder of 2021
Using Agency:	PCPO
Purchase Price:	\$40,000.00
Vendor:	Atlantic Tomorrows Office
Authority:	State Contract
Master P.O.	40467

**LET IT BE FURTHER RESOLVED**, that the Purchasing Agent and all other necessary officers and employees be and hereby are authorized and directed to take such further actions and sign such documents as are necessary to effectuate the purpose of this resolution, including but not limited to issuance of appropriate Purchase Orders.

LSP

Dated: August 10, 2021

CERTIFICATION OF AVAILABLE FUNDS

THIS IS TO CERTIFY THAT FUNDS ARE AVAILABLE AS FOLLOWS:

AMOUNT: \$40,000.00

APPROPRIATION: 1-01-20-109-001-219

PURPOSE: Authorizing the purchase of copier maintenance services from Atlantic Tomorrows Office for the Prosecutor's Office.

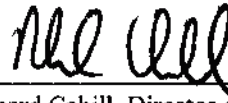

---

Richard Cahill, Director of Finance

DATED: August 10, 2021

# County of Passaic Board of County Commissioners

OFFICE OF COUNTY COMMISSIONERS

Director Pasquale "Pat" Lepore  
Deputy Director Bruce James  
Assad R. Akhter  
John W. Bartlett  
Theodore O. Best, Jr.  
Terry Duffy  
Cassandra "Sandi" Lazzara

401 Grand Street  
Paterson, New Jersey 07505

Tel: 973-881-4402  
Fax: 973-742-3746

Anthony J. De Nova III  
Administrator

Matthew P. Jordan, Esq.  
County Counsel

Louis E. Imhof, III, RMC  
Clerk Of The Board



## Public Meeting (Board Meeting)

Date: Aug 10, 2021 - 5:30 PM

Location: County Administration Building  
Webex - 220  
401 Grand Street  
Paterson, NJ 07505

Agenda: RESOLUTION AUTHORIZING THE PASSAIC COUNTY SHERIFF'S OFFICE TO AWARD A CONTRACT TO BIO-REFERENCE LABORATORIES FOR PHARMCEUTICAL SERVICES AT THE PASSAIC COUNTY JAIL, PURSUANT TO N.J.S.A. 40A:11-4.1, ET SEQ., ALL AS NOTED IN THE RESOLUTION.

THIS RESOLUTION WAS REQUESTED BY:

SHERIFF'S DEPT

REVIEWED BY:

Anthony J. De Nova III

COUNTY ADMINISTRATOR

APPROVED AS TO FORM AND LEGALITY:

Matthew P. Jordan, Esq.

COUNTY COUNSEL

Law and Public Safety

COMMITTEE NAME

<b>Official Resolution#</b>	<b>R20210764</b>							
Meeting Date	08/10/2021							
Introduced Date	08/10/2021							
Adopted Date	08/10/2021							
Agenda Item	I-48							
CAF #	1-01-25-157-005-M01							
Purchase Req. #	R1-13911							
Result	Adopted							
<b>COMMISSIONER</b>	<b>PRES.</b>	<b>ABS.</b>	<b>MOVE</b>	<b>SEC</b>	<b>AYE</b>	<b>NAY</b>	<b>ABST.</b>	<b>RECU.</b>
Lepore	✓				✓			
James	✓		✓		✓			
Akhter	✓			✓	✓			
Bartlett	✓				✓			
Best Jr.	✓				✓			
Duffy	✓				✓			
Lazzara	✓				✓			

PRES.= present ABS.= absent  
MOVE= moved SEC= seconded  
AYE= yes NAY= no ABST.= abstain  
RECU.= recuse

Dated: August 11, 2021

**RESOLUTION AUTHORIZING THE PASSAIC COUNTY SHERIFF'S OFFICE TO AWARD A CONTRACT TO BIO-REFERENCE LABORATORIES FOR PHARMECUTICAL SERVICES AT THE PASSAIC COUNTY JAIL, PURSUANT TO N.J.S.A. 40A:11-4.1, ET SEQ.**

**WHEREAS**, the County of Passaic (hereinafter the "County") is a body politic and corporate pursuant to N.J.S.A. 40:18-1 and vested with all rights contained therein; and

**WHEREAS**, pursuant to N.J.S.A. 40:20-1 the Board of County Commissioner of the County of Passaic (hereinafter the "Board") is vested with managing the property, finances, and affairs of the County; and

**WHEREAS**, N.J.S.A. 40A:11-4.1 authorizes the County to utilize competitive contracting in lieu of public bidding for procurement of specialized goods and services, the price of which exceeds the bid threshold; and

**WHEREAS**, N.J.S.A. 40A:11-4.1(e) specifically authorizes the County to use competitive contracting to procure vendors for a contract to perform laboratory testing services at the Passaic County Jail; and

**WHEREAS**, the Passaic County Sheriff's Office (hereinafter "PCSO"), which oversees the Passaic County Jail, previously requested to use competitive contracting to procure vendors for a contract to perform laboratory testing services at the jail; and

**WHEREAS**, pursuant to N.J.S.A. 40A:11-4.3 the Board approved Resolution No. R20210576, authorizing competitive contracting for laboratory testing services at the Passaic County Jail; and

**WHEREAS**, thereafter the Passaic County Purchasing Agent issued RFP-21-016, Laboratory Services for Passaic County Jail (hereinafter "RFP-21-016"), responses which were opened on July 8, 2021; and

**WHEREAS**, pursuant to N.J.S.A. 40A:11-4.5(d), in a memorandum dated August 4, 2021, which is attached to and made part of this resolution, the proposal submitted by Bio-Reference Laboratories, as the only bidder was reviewed and ranked based on a methodology for awarding of competitive contracts, which is management, technical and costs; and

**WHEREAS**, the August 4, 2021 memorandum is recommending an award of contract to Bio-Reference Laboratories for a three (3) year contract term from October 1, 2021 through September 30, 2024, with two (2), one-year options; and

**WHEREAS**, the PCSO has requested an appropriation for the first year of the contract in an amount not to exceed thirty thousand dollars (\$30,000), with the additional appropriations to be made thereafter by resolution; and

**WHEREAS**, this matter was discussed at the Law and Public Safety Committee meeting held on August 3, 2021 and is being recommended to the Board for approval; and

**WHEREAS**, funds are available in Account No. 1-01-25-157-005-M01 or any other account that may be deemed appropriate by the Chief Financial Officer or his designee, and the availability of funds has been contingently certified by the Chief Financial Officer subject to sufficient funds being appropriated by the Board in the 2021 and/or subsequent years' County budget(s), which is attached to and made part of this Resolution; and

**WHEREAS**, pursuant to N.J.S.A. 19:44A-20.4, the County's request for proposals is a fair and open process, specifically, the request for proposals case management services was publicly advertised, awarded under a process that provides for public solicitation of qualifications, established the basis of an award and disclosure process documented in writing prior to any solicitation, and is publicly opened and announced when awarded; and

**WHEREAS**, pursuant to N.J.S.A. 40A:11-23 the County issued RFP 21-016 advertisement for bids which was published in advance of the date fixed for receiving the bids to promote competitive bidding, the County received bids for RFP-21-016 on July 8, 2021; and

**NOW, THEREFORE, LET IT BE RESOLVED** that the Board of County Commissioners for the County of Passaic hereby authorizes the Passaic County Sheriff's Office to award a contract to Bio-Reference Laboratories for a three (3) year contract term from October 1, 2021 through September 30, 2024, with two (2) one-year options.

**LET IT BE FURTHER RESOLVED** that the Board authorizes an appropriation for the first year of the contract in an amount not to exceed thirty thousand dollars (\$30,000), with additional appropriations to be made thereafter by subsequent resolution.

**LET IT BE FURTHER RESOLVED**, the Clerk to the Board shall print, in the official newspaper, a brief notice stating the nature, duration, service, and the amount of the contract to Bio-Reference Laboratories, and maintain a copy of the resolution on file and available for public inspection in the Office of the Clerk to the Board; and

**LET IT BE FURTHER RESOLVED**, that the Clerk of the Board, County Counsel, County Administrator, Passaic County Sheriff, and Director of the Board of County Commissioners are authorized to execute an agreement and take any other steps necessary to carry out the purpose of this resolution.

LSP

August 10, 2021

COUNTY OF PASSAIC  
 SHERIFF'S DEPT, ATTN: SHANNAN  
 CO OF PASSAIC, (Q)973-247-3312  
 435 HAMBURG TURNPIKE  
 WAYNE, NJ 07470

REQUISITION	
NO.	R1-13911

S H I P T O	PASSAIC COUNTY SHERIFFS DEPT 11 MARSHALL STREET ATTN: MEDICAL PATERSON, NJ 07505
V E N D O R	VENDOR #: 01259 BIO-REFERENCE LABORATORIES 481 EDWARD H. ROSS DRIVE ELMWOOD PARK, NJ 07407

ORDER DATE: 07/29/21  
 DELIVERY DATE:  
 STATE CONTRACT:  
 F.O.B. TERMS:

QTY/UNIT	DESCRIPTION	ACCOUNT NO.	UNIT PRICE	TOTAL COST
1.00	LABORATORY SERVICES FOR THE PASSAIC COUNTY JAIL.  RFP-21-016 JULY 8, 2021  CONTRACT PERIOD OCTOBER 1, 2021 - SEPTEMBER 30, 2024. WITH TWO (1) YEAR OPTIONS.  PAID IN PARTIAL PAYMENTS  PENDING RESOLUTION	1-01-25-157-005-M01	30,000.0000	30,000.00
			TOTAL	30,000.00

Introduced on: August 10, 2021  
 Adopted on: August 10, 2021  
 Official Resolution#: R20210764

REQUESTING DEPARTMENT \_\_\_\_\_ DATE \_\_\_\_\_

CERTIFICATION OF AVAILABLE FUNDS

THIS IS TO CERTIFY THAT FUNDS ARE AVAILABLE AS FOLLOWS:

AMOUNT: \$30,000.00

APPROPRIATION: 1-01-25-157-005-M01

PURPOSE: Awarding contract Bio-Reference Laboratories for pharmaceutical services at the Passaic County Jail.

  
Richard Cahill, Director of Finance

DATED: August 10, 2021

# County of Passaic Board of County Commissioners

OFFICE OF COUNTY COMMISSIONERS

Director Pasquale "Pat" Lepore  
Deputy Director Bruce James  
Assad R. Akhter  
John W. Bartlett  
Theodore O. Best, Jr.  
Terry Duffy  
Cassandra "Sandi" Lazzara

401 Grand Street  
Paterson, New Jersey 07505  
Tel: 973-881-4402  
Fax: 973-742-3746

Anthony J. De Nova III  
*Administrator*  
Matthew P. Jordan, Esq.  
*County Counsel*  
Louis E. Imhof, III, RMC  
*Clerk Of The Board*



## Public Meeting (Board Meeting)

Date: Aug 10, 2021 - 5:30 PM

Location: County Administration Building  
Webex - 220  
401 Grand Street  
Paterson, NJ 07505

Agenda: RESOLUTION AUTHORIZING THE PASSAIC COUNTY SHERIFF'S OFFICE TO HIRE ENTRY LEVEL LAW ENFORCEMENT APPLICANTS WHO MEET THE EXEMPTIONS TO THE CIVIL SERVICE TESTING AS SET FORTH IN P.L. 2021, c. 7, ALL AS NOTED IN THE RESOLUTION.

THIS RESOLUTION WAS REQUESTED BY:

SHERIFF'S DEPT

REVIEWED BY:

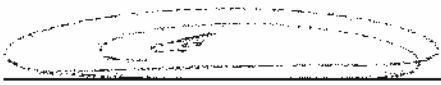
  
Anthony J. De Nova III

COUNTY ADMINISTRATOR

APPROVED AS TO FORM AND LEGALITY:

  
Matthew P. Jordan, Esq.

COUNTY COUNSEL

Law and Public Safety

COMMITTEE NAME

<b>Official Resolution#</b>	<b>R20210765</b>							
Meeting Date	08/10/2021							
Introduced Date	08/10/2021							
Adopted Date	08/10/2021							
Agenda Item	I-49							
CAF #								
Purchase Req. #								
Result	Adopted							
<b>COMMISSIONER</b>	<b>PRES.</b>	<b>ABS.</b>	<b>MOVE</b>	<b>SEC</b>	<b>AYE</b>	<b>NAY</b>	<b>ABST.</b>	<b>RECU.</b>
Lepore	✓				✓			
James	✓		✓		✓			
Akhter	✓			✓	✓			
Bartlett	✓				✓			
Best Jr.	✓				✓			
Duffy	✓				✓			
Lazzara	✓				✓			

PRES.= present ABS.= absent  
 MOVE= moved SEC= seconded  
 AYE= yes NAY= no ABST.= abstain  
 RECU.= recuse

Dated: August 11, 2021



**RESOLUTION AUTHORIZING THE PASSAIC COUNTY SHERIFF'S OFFICE TO HIRE ENTRY LEVEL LAW ENFORCEMENT APPLICANTS WHO MEET THE EXEMPTIONS TO THE CIVIL SERVICE TESTING AS SET FORTH IN P.L. 2021, c. 7**

**WHEREAS**, the County of Passaic (hereinafter the "County") is a body politic and corporate pursuant to N.J.S.A. 40:18-1 and vested with all rights contained therein; and

**WHEREAS**, pursuant to N.J.S.A. 40:20-1 the Board of County Commissioner of the County of Passaic (hereinafter the "Board") is vested with managing the property, finances, and affairs of the County; and

**WHEREAS**, on December 17, 2020, the New Jersey State Senate passed S3220, which creates an exemption to the requirement that all persons must pass the civil service law enforcement examination prior to becoming eligible for employment as entry-level law enforcement officers for individuals who have demonstrated successful completion of a police training course as approved by the New Jersey Police Training Commission; and

**WHEREAS**, on December 17, 2020, an identical bill, A5122 was passed by the New Jersey Assembly; and

**WHEREAS**, on February 4, 2021, Governor Phil Murphy signed P.L. 2021, c. 7 into law, which codified the civil service exemptions set forth by S3220 and A5122 effective August 4, 2021; and

**WHEREAS**, P.L. 2021, c. 7 requires a county police department to adopt a resolution of the governing body authorizing such hiring by the police department as well as a conflict of interest and nepotism policy; and

**WHEREAS**, the Passaic County Sheriff's Office (hereinafter "PCSO"), is desirous of being able to hire under the exemptions as set forth above, and have adopted a conflict of interest and nepotism policy as required; and

**WHEREAS**, this matter was discussed at the Law and Public Safety Committee meeting held on August 3, 2021 and is being recommended to the Board for approval; and

**NOW, THEREFORE, LET IT BE RESOLVED**, that the Board of County Commissioners for the County of Passaic hereby authorizes the Passaic County Sheriff's Office to hire entry-level law enforcement officers who are exempt from civil service testing pursuant to P.L. 2021, c. 7 and in accordance with its conflict of interest and nepotism policy.

**LET IT BE FURTHER RESOLVED**, that the Clerk of the Board, County Counsel, County Administrator, Passaic County Sheriff, and Director of the Board of County Commissioners are authorized to take any other steps necessary to carry out the purpose of this resolution.

LSP

August 10, 2021

# County of Passaic Board of County Commissioners

OFFICE OF COUNTY COMMISSIONERS

Director Pasquale "Pat" Lepore  
Deputy Director Bruce James  
Assad R. Akhter  
John W. Bartlett  
Theodore O. Best, Jr.  
Terry Duffy  
Cassandra "Sandi" Lazzara

401 Grand Street  
Paterson, New Jersey 07505  
Tel: 973-881-4402  
Fax: 973-742-3746

Anthony J. De Nova III  
*Administrator*  
Matthew P. Jordan, Esq.  
*County Counsel*  
Louis E. Imhof, III, RMC  
*Clerk Of The Board*



## Public Meeting (Board Meeting)

Date: Aug 10, 2021 - 5:30 PM

Location: County Administration Building  
Webex - 220  
401 Grand Street  
Paterson, NJ 07505

Agenda: RESOLUTION AUTHORIZING A NO-COST TIME EXTENSION TO 2019 ROUND OF MUNICIPAL AND NON-PROFIT GRANTS FROM THE OPEN SPACE, FARMLAND, AND HISTORIC PRESERVATION TRUST FUND PROGRAM TO THE BOROUGH OF WOODLAND PARK FOR THE DIANE GRIMES MEMORIAL PARK IMPROVEMENTS PROJECT, TO LEVERAGE THE SAID GRANT TO COINCIDE WITH 2020 ROUND OF GRANT FUNDING FOR SAME PROJECT, ALL AS NOTED IN THE RESOLUTION.

THIS RESOLUTION WAS REQUESTED BY:

PLANNING BOARD

REVIEWED BY:

Anthony J. De Nova III  
COUNTY ADMINISTRATOR

APPROVED AS TO FORM AND LEGALITY:

Matthew P. Jordan, Esq.  
COUNTY COUNSEL

Planning and Economic Development  
COMMITTEE NAME

<b>Official Resolution#</b>	<b>R20210766</b>							
Meeting Date	08/10/2021							
Introduced Date	08/10/2021							
Adopted Date	08/10/2021							
Agenda Item	I-50							
CAF #								
Purchase Req. #								
Result	Adopted							
<b>COMMISSIONER</b>	<b>PRES.</b>	<b>ABS.</b>	<b>MOVE</b>	<b>SEC</b>	<b>AYE</b>	<b>NAY</b>	<b>ABST.</b>	<b>RECU.</b>
Lepore	✓				✓			
James	✓		✓		✓			
Akhter	✓			✓	✓			
Bartlett	✓				✓			
Best Jr.	✓				✓			
Duffy	✓				✓			
Lazzara	✓				✓			

PRES.= present ABS.= absent  
 MOVE= moved SEC= seconded  
 AYE= yes NAY= no ABST.= abstain  
 RECU.= recuse

Dated: August 11, 2021

**RESOLUTION AUTHORIZING A NO-COST TIME EXTENSION TO 2019 ROUND OF MUNICIPAL AND NON-PROFIT GRANTS FROM THE OPEN SPACE, FARMLAND, AND HISTORIC PRESERVATION TRUST FUND PROGRAM TO THE BOROUGH OF WOODLAND PARK FOR THE DIANE GRIMES MEMORIAL PARK IMPROVEMENTS PROJECT, TO LEVERAGE THE SAID GRANT TO COINCIDE WITH 2020 ROUND OF GRANT FUNDING FOR SAME PROJECT.**

**WHEREAS**, the Board of County Commissioners of the County of Passaic (hereafter "Board") created an Open Space, Farmland and Historic Preservation Trust Fund Program (hereafter "Program") in conformity with the will of the voters in the 1996 election, as authorized by N.J.S.A. 40:12-15.2; and

**WHEREAS**, the purpose and goals of the above is to achieve, in partnership with others, a system of interconnected open spaces, whose protection will preserve and enhance New Jersey's natural environment and its historic, scenic, and recreational resources for public use and enjoyment; and

**WHEREAS**, pursuant to Resolution R2019-0588, dated June 25, 2019, the Board awarded funding under the 2019 round of Municipal and Non-Profit grants from the Program for the Borough of Woodland Park (hereafter "Borough"), Diane Grimes Memorial Park Improvements Project; and

**WHEREAS**, the grant funds of \$25,000.00 are to be used for upgraded playground equipment and surface, walkways, signage, and trash/recycling receptacles; and

**WHEREAS**, pursuant to the Program Rules and Regulations (hereafter "Rules") promulgated by the Board, specifically Chapter 11, Paragraph 1(a), the Project Agreement requires a two (2) year project term whereby all Program monies must be distributed; and

**WHEREAS**, pursuant to the said Rules, the date of execution of the Project Agreement shall begin the two (2) year clock on the project, and the time period presently is due to end August 9, 2021; and

**WHEREAS**, the Borough Mayor has requested a project extension (copy attached) to May 18, 2023, to coincide with the 2020 round of grant funding so that the original \$25,000.00 can be leveraged with the 2020 grant awarded for the same project, awarded on April 27, 2021, pursuant to Resolution R20210446 with a deadline of May 18, 2023;

**WHEREAS**, the Board is desirous of authorizing a no-cost extension to the Borough for the Diane Grimes Memorial Park Improvement Project grant from the Program until May 18, 2023 to account for amount to be leveraged with the 2020 grant awarded for the same project; and

**WHEREAS**, this matter was reviewed and discussed at the July 29, 2021, meeting of the Planning and Economic Development Committee and being recommended to the Board for approval; and

**NOW THEREFORE, LET IT BE RESOLVED** that the Board of County Commissioners of the County of Passaic authorize an extension to the 2019 round of Municipal and Non-Profit grants from the Open Space, Farmland, and Historic Preservation Trust Fund to the Borough of Woodland Park, Diane Grimes Memorial Park Improvement Project until May 18, 2023 to coincide with the 2020 round of grant funding for the same project; and

**LET IT BE FURTHER RESOLVED** that the Director and Clerk are hereby authorized to execute the necessary agreements to effectuate the extension referenced above.

JDP

Dated: August 10, 2021



# Borough of Woodland Park

*Office of the Mayor*

**Keith Kazmark**  
*Mayor*

Passaic County, NJ  
5 Brophy Lane  
Woodland Park, NJ 07424  
Office: (973) 345-8100 x 210  
Fax: (973) 345-8194  
Home: (973) 684-3604  
Cell: (973) 420-9962  
E-Mail: [kkazmark@wprnj.us](mailto:kkazmark@wprnj.us)

Michael Lysicatos  
Planning Director  
Dept. of Planning & Economic Development  
County of Passaic  
401 Grand Street, Room 417  
Paterson, NJ 07505

July 23, 2021

Director Lysicatos:

Regarding your e-mail correspondence of July 22, 2021, the Borough of Woodland Park respectfully requests an extension of the deadline for the following County Open Space Grant, specifically:

- **Open Space Grant for Diane Grimes Park: \$25,000**

As you are aware, the Borough of Woodland Park intends to leverage the said grant for Diane Grimes Park with the most recent grant that was awarded on May 18, 2021. Therefore, the Borough is seeking an extension beyond the contract deadline of August 9, 2021, as we are truly trying to improve the park's facilities with multiple grant initiatives.

Please advise if you need anything more.

Sincerely,

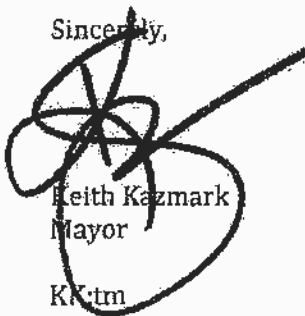

Keith Kazmark  
Mayor  
KK:tm

# County of Passaic Board of County Commissioners

OFFICE OF COUNTY COMMISSIONERS

Director Pasquale "Pat" Lepore  
Deputy Director Bruce James  
Assad R. Akhter  
John W. Bartlett  
Theodore O. Best, Jr.  
Terry Duffy  
Cassandra "Sandi" Lazzara

401 Grand Street  
Paterson, New Jersey 07505  
Tel: 973-881-4402  
Fax: 973-742-3746

Anthony J. De Nova III  
*Administrator*  
Matthew P. Jordan, Esq.  
*County Counsel*  
Louis E. Imhof, III, RMC  
*Clerk Of The Board*



## Public Meeting (Board Meeting)

Date: Aug 10, 2021 - 5:30 PM

Location: County Administration Building  
Webex - 220  
401 Grand Street  
Paterson, NJ 07505

Agenda: RESOLUTION AUTHORIZING A NO-COST TIME EXTENSION TO 2019 ROUND OF MUNICIPAL AND NON-PROFIT GRANTS FROM THE OPEN SPACE, FARMLAND, AND HISTORIC PRESERVATION TRUST FUND PROGRAM TO THE COMMUNITY ASSOCIATION OF THE HIGHLANDS, RINGWOOD FOR THE UPGRADE AND REHABILITATION OF HIGHLANDS NATURAL POOL TO SPEND DOWN BALANCE OF FUNDS, ALL AS NOTED IN THE RESOLUTION., ALLAS NOTED IN THE RESOLUTION.

THIS RESOLUTION WAS REQUESTED BY:

PLANNING BOARD

REVIEWED BY:

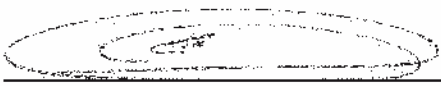
  
Anthony J. De Nova III  
COUNTY ADMINISTRATOR

APPROVED AS TO FORM AND LEGALITY:

  
Matthew P. Jordan, Esq.  
COUNTY COUNSEL

Planning and Economic Development  
COMMITTEE NAME

<b>Official Resolution#</b>	<b>R20210767</b>							
Meeting Date	08/10/2021							
Introduced Date	08/10/2021							
Adopted Date	08/10/2021							
Agenda Item	I-51							
CAF #								
Purchase Req. #								
Result	Adopted							
<b>COMMISSIONER</b>	<b>PRES.</b>	<b>ABS.</b>	<b>MOVE</b>	<b>SEC</b>	<b>AYE</b>	<b>NAY</b>	<b>ABST.</b>	<b>RECU.</b>
Lepore	✓				✓			
James	✓		✓		✓			
Akhter	✓			✓	✓			
Bartlett	✓				✓			
Best Jr.	✓				✓			
Duffy	✓				✓			
Lazzara	✓				✓			

PRES.= present ABS.= absent  
 MOVE= moved SEC= seconded  
 AYE= yes NAY= no ABST.= abstain  
 RECU.= recuse

Dated: August 11, 2021

**RESOLUTION AUTHORIZING A NO-COST TIME EXTENSION TO 2019 ROUND OF MUNICIPAL AND NON-PROFIT GRANTS FROM THE OPEN SPACE, FARMLAND, AND HISTORIC PRESERVATION TRUST FUND PROGRAM TO THE COMMUNITY ASSOCIATION OF THE HIGHLANDS, RINGWOOD FOR THE UPGRADE AND REHABILITATION OF HIGHLANDS NATURAL POOL TO SPEND DOWN BALANCE OF FUNDS.**

**WHEREAS**, the Board of County Commissioners of the County of Passaic (hereafter "Board") created an Open Space, Farmland and Historic Preservation Trust Fund Program (hereafter "Program") in conformity with the will of the voters in the 1996 election, as authorized by N.J.S.A. 40:12-15.2; and

**WHEREAS**, the purpose and goals of the above is to achieve, in partnership with others, a system of interconnected open spaces, whose protection will preserve and enhance New Jersey's natural environment and its historic, scenic, and recreational resources for public use and enjoyment; and

**WHEREAS**, pursuant to Resolution R2019-0588, dated June 25, 2019, the Board awarded funding under the 2019 round of Municipal and Non-Profit grants from the Program for the Community Association of the Highlands, Inc., The Highlands Natural Pool, Ringwood, Project (hereafter "Community"); and

**WHEREAS**, the grant funds of \$14,039.00 are to be used for ongoing repair of spillway, expanded sitting area, and additional furniture; and

**WHEREAS**, pursuant to the Program Rules and Regulations (hereafter "Rules") promulgated by the Board, specifically Chapter 11, Paragraph 1(a), the Project Agreement requires a two (2) year project term whereby all Program monies must be distributed; and

**WHEREAS**, pursuant to the said Rules, the date of execution of the Project Agreement shall begin the two (2) year clock on the project, and the time period presently is due to end August 9, 2021; and

**WHEREAS**, the Vice-President and Co-Founder of the Community has requested a project extension (copy attached) to December 31, 2021 to spend down the remaining balance of \$549.00 from the 2019 grant;

**WHEREAS**, the Board is desirous of authorizing a no-cost extension to the Community until December 31, 2021 so that the Community can spend down the remaining balance from the 2019 grant; and

**WHEREAS**, this matter was reviewed and discussed at the July 29, 2021 meeting of the Planning and Economic Development Committee and being recommended to the Board for approval; and

**NOW THEREFORE, LET IT BE RESOLVED** that the Board of County Commissioners of the County of Passaic authorize an extension to the 2019 round of Municipal and Non-Profit grants from the Open Space, Farmland, and Historic Preservation Trust Fund to the Community Association of the Highlands, Inc., The Highlands Natural Pool, Ringwood, until December 31, 2021; and

**LET IT BE FURTHER RESOLVED** that the Director and Clerk are hereby authorized to execute the necessary agreements to effectuate the extension referenced above.

JDP

Dated: August 10, 2021

# The Highlands Natural Pool

*"We are not just a pool — we are a community"*

July 22, 2021

**Michael Lysicatos AICP, PP**  
**Planning Director**

**Passaic County Department of Planning & Economic Development**  
**401 Grand Street, Suite 417**  
**Paterson, New Jersey 07505**

**Re: Remaining Funds from The Highlands Natural Pool's 2019 Open Space Trust Fund Park Development Grant**

**Dear Mr. Lysicatos,**

**As mentioned in our October 22, 2020 grant application cover letter, and noted on Page 3 of the application form, we have a small, remaining balance of \$549 from our 2019 Grant.**

**We request that this 2019 balance be held for us for the remainder of this year, although it is our intention to use the funds well prior.**

**Thank you,**

  
**Jon Berry, Vice President & Co-Founder**

The Highlands Natural Pool is Owned and Operated by the  
**Community Association of the Highlands, Inc.**

a 501(c) 3 non-profit organization established in 1997

Location & Mailing Address: 180 Snake Den Road, Ringwood, NJ 07456

Telephone: (973) 835-4299

On the web at [www.highlandsnaturalpool.org](http://www.highlandsnaturalpool.org)

Introduced on: August 10, 2021  
Adopted on: August 10, 2021  
Official Resolution#: R20210767

# County of Passaic Board of County Commissioners

OFFICE OF COUNTY COMMISSIONERS

Director Pasquale "Pat" Lepore  
Deputy Director Bruce James  
Assad R. Akhter  
John W. Bartlett  
Theodore O. Best, Jr.  
Terry Duffy  
Cassandra "Sandi" Lazzara

401 Grand Street  
Paterson, New Jersey 07505

Tel: 973-881-4402  
Fax: 973-742-3746

Anthony J. De Nova III  
Administrator

Matthew P. Jordan, Esq.  
County Counsel

Louis E. Imhof, III, RMC  
Clerk Of The Board



## Public Meeting (Board Meeting)

Date: Aug 10, 2021 - 5:30 PM

Location: County Administration Building  
Webex - 220  
401 Grand Street  
Paterson, NJ 07505

Agenda: RESOLUTION AUTHORIZING A NO-COST TIME EXTENSION TO 2019 ROUND OF MUNICIPAL AND NON-PROFIT GRANTS FROM THE OPEN SPACE, FARMLAND, AND HISTORIC PRESERVATION TRUST FUND PROGRAM TO THE HIGHLANDS NATURE FRIENDS, INC., FOR REHABILITATION OF THE WEISS CENTER IN RINGWOOD TO ACCOUNT FOR IMPACTS OF COVID-19 ON PERMITTING DELAYS AND DISRUPTIONS TO THE CONTRACTOR, ALL AS NOTED IN THE RESOLUTION.

THIS RESOLUTION WAS REQUESTED BY:

PLANNING BOARD

REVIEWED BY:

Anthony J. De Nova III  
COUNTY ADMINISTRATOR

APPROVED AS TO FORM AND LEGALITY:

Matthew P. Jordan, Esq.  
COUNTY COUNSEL

Planning and Economic Development  
COMMITTEE NAME

<b>Official Resolution#</b>	<b>R20210768</b>							
Meeting Date	08/10/2021							
Introduced Date	08/10/2021							
Adopted Date	08/10/2021							
Agenda Item	I-52							
CAF #								
Purchase Req. #								
Result	Adopted							
<b>COMMISSIONER</b>	<b>PRES.</b>	<b>ABS.</b>	<b>MOVE</b>	<b>SEC</b>	<b>AYE</b>	<b>NAY</b>	<b>ABST.</b>	<b>RECU.</b>
Lepore	✓				✓			
James	✓		✓		✓			
Akhter	✓			✓	✓			
Bartlett	✓				✓			
Best Jr.	✓				✓			
Duffy	✓				✓			
Lazzara	✓				✓			

PRES.= present ABS.= absent  
MOVE= moved SEC= seconded  
AYE= yes NAY= no ABST.= abstain  
RECU.= recuse

Dated: August 11, 2021



**RESOLUTION AUTHORIZING A NO-COST TIME EXTENSION TO 2019 ROUND OF MUNICIPAL AND NON-PROFIT GRANTS FROM THE OPEN SPACE, FARMLAND, AND HISTORIC PRESERVATION TRUST FUND PROGRAM TO THE HIGHLANDS NATURE FRIENDS, INC., FOR REHABILITATION OF THE WEISS CENTER IN RINGWOOD TO ACCOUNT FOR IMPACTS OF COVID-19 ON PERMITTING DELAYS AND DISRUPTIONS TO THE CONTRACTOR.**

**WHEREAS**, the Board of County Commissioners of the County of Passaic (hereafter "Board") created an Open Space, Farmland and Historic Preservation Trust Fund Program (hereafter "Program") in conformity with the will of the voters in the 1996 election, as authorized by N.J.S.A. 40:12-15.2; and

**WHEREAS**, the purpose and goals of the above is to achieve, in partnership with others, a system of interconnected open spaces, whose protection will preserve and enhance New Jersey's natural environment and its historic, scenic, and recreational resources for public use and enjoyment; and

**WHEREAS**, pursuant to Resolution R2019-0588, dated June 25, 2019, the Board awarded funding under the 2019 round of Municipal and Non-Profit grants from the Program for the Highlands Nature Friends, Inc., for the rehabilitation of the Weiss Center in Ringwood; and

**WHEREAS**, the grant funds of \$52,993.00 are to be used to upgrade buildings, inside and out, such as Americans with Disabilities Act restrooms, window shades and locks, heating, replacement of doors, installation of pavers, restoration of electrical service; and

**WHEREAS**, pursuant to the Program Rules and Regulations (hereafter "Rules") promulgated by the Board, specifically Chapter 11, Paragraph 1(a), the Project Agreement requires a two (2) year project term whereby all Program monies must be distributed; and

**WHEREAS**, pursuant to the said Rules, the date of execution of the Project Agreement shall begin the two (2) year clock on the project, and the time period presently is due to end forthwith; and

**WHEREAS**, the President & Co-Founder of The Highlands Nature Friends, Inc., The New Weis Center for Education, Arts & Recreation has requested a project extension (copy attached) for the fire alarm upgrade to be completed by December 31, 2021; and

**WHEREAS**, the Board is desirous of authorizing a no-cost extension to the Highland Nature Friends, Inc., grant from the Program until December 31, 2021 to account for the impacts of COVID-19 on permitting delays and disruptions to the contractor; and

**WHEREAS**, this matter was reviewed and discussed at the July 29, 2021 meeting of the Planning and Economic Development Committee and being recommended to the Board for approval; and

**NOW THEREFORE, LET IT BE RESOLVED** that the Board of County Commissioners of the County of Passaic authorize an extension to the 2019 round of Municipal and Non-Profit grants from the Open Space, Farmland, and Historic Preservation Trust Fund to The Highlands Nature Friends, Inc., The New Weis Center for Education, Arts & Recreation in Ringwood, New Jersey until December 31, 2021 to account for the impact of COVID-19 on permitting delays and disruptions to the contractor; and

**LET IT BE FURTHER RESOLVED** that the Director and Clerk are hereby authorized to execute the necessary agreements to effectuate the extension referenced above.

JDP

Dated: August 10, 2021



**The Highlands Nature Friends, Inc.**  
a 501(c)3 non-profit organization

## **The New Weis Center for Education, Arts & Recreation**

July 20, 2021

**Michael Lysicatos AICP, PP**  
Planning Director  
Passaic County Department of Planning & Economic Development  
401 Grand Street, Suite 417  
Paterson, New Jersey 07505

**Re: Status of Project to Replace Antiquated Fire Alarm System; Funds from 2019 Open Space Trust Fund Park Development Grant**

Dear Mr. Lysicatos,  
Subsequent to our March 2021 letter to you about this project, we continued to experience delays due to the pandemic, including the limited availability of required professional services.

Now, however, we are pleased to report that we have cleared the hurdle of obtaining the detailed drawings, recently developed and revised by our architect in conjunction with our fire alarm installer.

This will enable us to resubmit our building permit application, which we will do within the week.

We cannot predict how long the municipality will take to issue the permit, and our alarm contractor is backed up from the period of time when he was unable to work due to the pandemic (and shortages in many industries may create a delay in obtaining certain parts).

Therefore we are formally and respectfully requesting that the remaining balance of funds from our 2019 Grant, \$10,452.38, which is earmarked specifically for this badly needed fire alarm upgrade project, continue to be held for us for the remainder of the year.

Although we are making every effort to complete this project well before December 2021, we are asking for this extended time in order to account for any unanticipated circumstances.

Thank you,

  
**Jon Berry,**  
President & Co-Founder

150 Snake Den Road, Ringwood, New Jersey 07456 Tel. (973) 835-2160

Introduced on: ~~August 10, 2021~~ [www.HighlandsNatureFriends.org](http://www.HighlandsNatureFriends.org) E-mail: [info@HighlandsNatureFriends.org](mailto:info@HighlandsNatureFriends.org)  
Adopted on: August 10, 2021  
Official Resolution#: R20210768

# County of Passaic Board of County Commissioners

OFFICE OF COUNTY COMMISSIONERS

Director Pasquale "Pat" Lepore  
Deputy Director Bruce James  
Assad R. Akhter  
John W. Bartlett  
Theodore O. Best, Jr.  
Terry Duffy  
Cassandra "Sandi" Lazzara

401 Grand Street  
Paterson, New Jersey 07505

Tel: 973-881-4402  
Fax: 973-742-3746

Anthony J. De Nova III  
Administrator

Matthew P. Jordan, Esq.  
County Counsel

Louis E. Imhof, III, RMC  
Clerk Of The Board



## Public Meeting (Board Meeting)

Date: Aug 10, 2021 - 5:30 PM

Location: County Administration Building  
Webex - 220  
401 Grand Street  
Paterson, NJ 07505

Agenda: RESOLUTION AUTHORIZING A NO-COST TIME EXTENSION TO 2019 ROUND OF MUNICIPAL AND NON-PROFIT GRANTS FROM THE OPEN SPACE, FARMLAND, AND HISTORIC PRESERVATION TRUST FUND PROGRAM TO THE BOROUGH OF BLOOMINGDALE, WALTER T. BERGEN TENNIS COURT PROJECT, TO ACCOUNT FOR IMPACTS OF COVID-19 ON ADMINISTRATION AND CONSTRUCTION ACTIVITIES, ALL AS NOTED IN THE RESOLUTION.

THIS RESOLUTION WAS REQUESTED BY:

PLANNING BOARD

REVIEWED BY:

Anthony J. De Nova III  
COUNTY ADMINISTRATOR

APPROVED AS TO FORM AND LEGALITY:

Matthew P. Jordan, Esq.  
COUNTY COUNSEL

Planning and Economic Development  
COMMITTEE NAME

<b>Official Resolution#</b>	<b>R20210769</b>							
Meeting Date	08/10/2021							
Introduced Date	08/10/2021							
Adopted Date	08/10/2021							
Agenda Item	I-53							
CAF #								
Purchase Req. #								
Result	Adopted							
<b>COMMISSIONER</b>	<b>PRES.</b>	<b>ABS.</b>	<b>MOVE</b>	<b>SEC</b>	<b>AYE</b>	<b>NAY</b>	<b>ABST.</b>	<b>RECU.</b>
Lepore	✓				✓			
James	✓		✓		✓			
Akhter	✓			✓	✓			
Bartlett	✓				✓			
Best Jr.	✓				✓			
Duffy	✓				✓			
Lazzara	✓				✓			

PRES.= present ABS.= absent  
MOVE= moved SEC= seconded  
AYE= yes NAY= no ABST.= abstain  
RECU.= recuse

Dated: August 11, 2021

**RESOLUTION AUTHORIZING A NO-COST TIME EXTENSION TO 2019 ROUND OF MUNICIPAL AND NON-PROFIT GRANTS FROM THE OPEN SPACE, FARMLAND, AND HISTORIC PRESERVATION TRUST FUND PROGRAM TO THE BOROUGH OF BLOOMINGDALE, WALTER T. BERGEN TENNIS COURT PROJECT, TO ACCOUNT FOR IMPACTS OF COVID-19 ON ADMINISTRATION AND CONSTRUCTION ACTIVITIES.**

**WHEREAS**, the Board of County Commissioners of the County of Passaic (hereafter "Board") created an Open Space, Farmland and Historic Preservation Trust Fund Program (hereafter "Program") in conformity with the will of the voters in the 1996 election, as authorized by N.J.S.A. 40:12-15.2; and

**WHEREAS**, the purpose and goals of the above is to achieve, in partnership with others, a system of interconnected open spaces, whose protection will preserve and enhance New Jersey's natural environment and its historic, scenic, and recreational resources for public use and enjoyment; and

**WHEREAS**, pursuant to Resolution R2019-0588, dated June 25, 2019, the Board awarded funding under the 2019 round of Municipal and Non-Profit grants from the Program for the Borough of Bloomingdale (hereafter "Borough"), Walter T. Bergen Tennis Project; and

**WHEREAS**, the grant funds of \$99,000.00 are to be used for complete overhaul of tennis courts, including new asphalt, netting, lighting, and striping; and

**WHEREAS**, pursuant to the Program Rules and Regulations (hereafter "Rules") promulgated by the Board, specifically Chapter 11, Paragraph 1(a), the Project Agreement requires a two (2) year project term whereby all Program monies must be distributed; and

**WHEREAS**, pursuant to the said Rules, the date of execution of the Project Agreement shall begin the two (2) year clock on the project, and the time period presently is due to end forthwith; and

**WHEREAS**, the Borough Administrator has requested a project extension (copy attached) to be completed by December 31, 2021; and

**WHEREAS**, the Board is desirous of authorizing a no-cost extension to the Borough for the Walter T. Bergen Tennis Project grant from the Program until December 31, 2021 to account for the impacts of COVID-19 on administration and construction activities; and

**WHEREAS**, this matter was reviewed and discussed at the July 29, 2021 meeting of the Planning and Economic Development Committee and being recommended to the Board for approval; and

**NOW THEREFORE, LET IT BE RESOLVED** that the Board of County Commissioners of the County of Passaic authorize an extension to the 2019 round of Municipal and Non-Profit grants from the Open Space, Farmland, and Historic Preservation Trust Fund to the Borough of Bloomingdale, Walter T. Bergen Tennis Project until December 31, 2021 to account for the impact of COVID-19 on administration and construction activities; and

**LET IT BE FURTHER RESOLVED** that the Director and Clerk are hereby authorized to execute the necessary agreements to effectuate the extension referenced above.

JDP

Dated: August 10, 2021



## BOROUGH OF BLOOMINGDALE

101 HAMBURG TURNPIKE · BLOOMINGDALE, NEW JERSEY 07403  
(TEL) 973-838-0778 (FAX) 973-838-5115

July 22, 2021

Michael Lysicatos AICP, PP – Planning Director  
401 Grand Street, Suite 417  
Paterson, NJ 07505

Re: Request for Extension  
2019 Passaic County Open Space Trust Fund Grant  
Walter T. Bergen Tennis Court Project

Dear Planning Director Lysicatos,

As you are aware, the Borough was awarded \$99,000.00 for the Walter T. Bergen Tennis Court project. Due to Covid and the unexpected passing of Mayor Jonathan Dunleavy, the anticipated timeline of this project has been delayed. While the Borough continues to progress through these challenges, I am working diligently with our Professionals to continue with this project as intended, with the goal of completion by years end.

Please accept this letter as a formal request for a no-cost time extension of the 2019 Passaic County Open Space Trust Fund Grant award to December 31, 2021. Thank you for the consideration in this matter.

Sincerely,

*Mike Sondermeyer*

Michael Sondermeyer  
Borough Administrator  
101 Hamburg Turnpike  
Bloomingdale, N.J. 07403  
Office: 973-838-0778 X-243  
Cell: 862-330-8238  
[Msondermeyer@bloomingdalenj.net](mailto:Msondermeyer@bloomingdalenj.net)

[www.bloomingdalenj.net](http://www.bloomingdalenj.net)

Introduced on: August 10, 2021  
Adopted on: August 10, 2021  
Official Resolution#: R20210769

4

# County of Passaic Board of County Commissioners

OFFICE OF COUNTY COMMISSIONERS

Director Pasquale "Pat" Lepore  
Deputy Director Bruce James  
Assad R. Akhter  
John W. Bartlett  
Theodore O. Best, Jr.  
Terry Duffy  
Cassandra "Sandi" Lazzara

401 Grand Street  
Paterson, New Jersey 07505  
Tel: 973-881-4402  
Fax: 973-742-3746

Anthony J. De Nova III  
*Administrator*  
Matthew P. Jordan, Esq.  
*County Counsel*  
Louis E. Imhof, III, RMC  
*Clerk Of The Board*



## Public Meeting (Board Meeting)

Date: Aug 10, 2021 - 5:30 PM

Location: County Administration Building  
Webex - 220  
401 Grand Street  
Paterson, NJ 07505

Agenda: RESOLUTION AUTHORIZING A SECOND NO COST TIME EXTENSION FOR THE COMMUNITY DEVELOPMENT BLOCK GRANT PROGRAM FY 2018 WOODLAND PARK LIBRARY AMERICANS WITH DISABILITIES ACT COMPLIANT DOORS PROJECT UNTIL DECEMBER 31, 2021, ALL AS NOTED IN THE RESOLUTION.

THIS RESOLUTION WAS REQUESTED BY:

ECONOMIC DEVELOPMENT

REVIEWED BY:

Anthony J. De Nova III

COUNTY ADMINISTRATOR

APPROVED AS TO FORM AND LEGALITY:

Matthew P. Jordan, Esq.

COUNTY COUNSEL

Planning and Economic Development

COMMITTEE NAME

<b>Official Resolution#</b>	<b>R20210770</b>							
Meeting Date	08/10/2021							
Introduced Date	08/10/2021							
Adopted Date	08/10/2021							
Agenda Item	I-54							
CAF #								
Purchase Req. #								
Result	Adopted							
<b>COMMISSIONER</b>	<b>PRES.</b>	<b>ABS.</b>	<b>MOVE</b>	<b>SEC</b>	<b>AYE</b>	<b>NAY</b>	<b>ABST.</b>	<b>RECU.</b>
Lepore	✓				✓			
James	✓		✓		✓			
Akhter	✓			✓	✓			
Bartlett	✓				✓			
Best Jr.	✓				✓			
Duffy	✓				✓			
Lazzara	✓				✓			

PRES.= present ABS.= absent  
MOVE= moved SEC= seconded  
AYE= yes NAY= no ABST.= abstain  
RECU.= recuse

**Dated: August 11, 2021**

**RESOLUTION AUTHORIZING A SECOND NO COST TIME  
EXTENSION FOR THE COMMUNITY DEVELOPMENT BLOCK  
GRANT PROGRAM FY 2018 WOODLAND PARK LIBRARY  
AMERICANS WITH DISABILITIES ACT COMPLIANT DOORS  
PROJECT UNTIL DECEMBER 31, 2021.**

**WHEREAS**, the Passaic County Board of County Commissioners (hereafter “Board”) adopted Resolution R-2018-0536 on June 26, 2018, authorizing the submission of a Five (5) Year Consolidated Plan for the period of FY 2018-2022 to the US Department of Housing and Urban Development (hereafter “USHUD”) in compliance with the rules and regulations governing the Community Development Block Grant Program (hereafter “CDBG”); and

**WHEREAS**, the Board adopted the FY 2018 Annual Action Plan via Resolution R-2018-0536 on June 26, 2018; and

**WHEREAS**, the Board is cognizant of the conditions imposed by the USHUD and included a grant allocation in the FY 2018 Annual Action Plan to the Borough of Woodland Park (hereafter “Borough”) for \$75,000.00 to implement the Woodland Park Library Americans with Disabilities Act (hereafter “ADA”) Compliant Doors Project; and

**WHEREAS**, the Board adopted Resolution R-2020-0542 dated June 30, 2020 to provide a FIRST no-cost-time extension of the CDBG FY 2018 Woodland Park Library ADA Compliant Doors Project until August 31, 2021; and

**WHEREAS**, the Borough has notified the Division of Economic Development, see attached correspondence, that the Borough has been delayed in the implementation of the project due to a significant delay in the award of a NJ State matching grant for the project and is requesting that the CDBG FY 2018 grant award be extended for the second time to December 31, 2021 to permit the Borough to complete the project; and

**WHEREAS**, this matter was discussed at the July 29, 2021 meeting of the County Commissioner Planning and Economic Development Committee and is being recommended to the Board for approval; and

**WHEREAS**, the Board considers this matter to be a benefit to the community and its residents;

**NOW THEREFORE BE IT RESOLVED** by the Board of County Commissioners of the County of Passaic that it hereby authorizes the second no-cost time extension of the Community Development Block Grant Program FY 2018 grant to the Borough of Woodland Park to December 31, 2021 as set forth above; and

**LET IT BE FURTHER RESOLVED**, that the County of Passaic Commissioner Director and Director of Economic Development are hereby authorized to act as the authorized representatives of the County to execute all necessary documents and certifications on behalf of the County of Passaic.

JDP

Dated: August 10, 2021

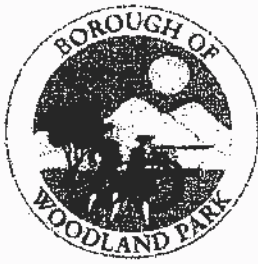

# *Borough of Woodland Park*

*Office of the Mayor*

**Keith Kazmark**  
Mayor

Passaic County, NJ  
5 Brophy Lane  
Woodland Park, NJ 07424  
Office: (973) 345-8100 x 210  
Fax: (973) 345-8194  
Home: (973) 684-3604  
Cell: (973) 420-9962  
E-Mail: [kkazmark@wprnj.us](mailto:kkazmark@wprnj.us)

Deborah Hoffman  
Division Director  
Economic Development Div.  
County of Passaic  
930 Riverview Dr., Suite 250  
Totowa, NJ 07512

July 19, 2021

Director Hoffman:

Regarding your e-mail correspondence of July 13, 2021, the Borough of Woodland Park respectfully requested an extension of the deadline for the following Community Development Block Grant, specifically:

- **CDBG FY 2018: Woodland Park Alfred H Baumann Free Public Library Installation of ADA Compliant Doors and ADA parking space: \$75,000**

As you are aware, the Alfred H. Baumann Library has applied for the New Jersey Library Construction grant and those awards should be announced by the end of September. Should the Library be awarded the grant, we would like to use the above CDBG grant in tandem with the library grant.

We are requesting the funds be extended beyond the December 31, 2021 timeframe, as we are truly trying to improve the public library with multiple grant initiatives.

Please advise if you need anything more.

Sincerely,



Keith Kazmark  
Mayor

KK:tm

CC: Linda Hoffman, Alfred H. Baumann Free Public Library

Introduced on: August 10, 2021  
Adopted on: August 10, 2021  
Official Resolution#: R20210770



# County of Passaic Board of County Commissioners

OFFICE OF COUNTY COMMISSIONERS

Director Pasquale "Pat" Lepore  
Deputy Director Bruce James  
Assad R. Akhter  
John W. Bartlett  
Theodore O. Best, Jr.  
Terry Duffy  
Cassandra "Sandi" Lazzara

401 Grand Street  
Paterson, New Jersey 07505  
Tel: 973-881-4402  
Fax: 973-742-3746

Anthony J. De Nova III  
*Administrator*  
Matthew P. Jordan, Esq.  
*County Counsel*  
Louis E. Imhof, III, RMC  
*Clerk Of The Board*



## Public Meeting (Board Meeting)

Date: Aug 10, 2021 - 5:30 PM

Location: County Administration Building  
Webex - 220  
401 Grand Street  
Paterson, NJ 07505

Agenda: RESOLUTION AUTHORIZING A NO COST TIME EXTENSION FOR THE COMMUNITY DEVELOPMENT BLOCK GRANT PROGRAM FY 2019 TOWNSHIP OF WEST MILFORD PROJECT TO PROVIDE AMERICANS WITH DISABILITIES ACT ACCESSIBILITY TO THE BATHROOM IN MUNICIPAL BUILDING NO. 1 UNTIL OCTOBER 31, 2021, ALL AS NOTED IN THE RESOLUTION.

THIS RESOLUTION WAS REQUESTED BY:

ECONOMIC DEVELOPMENT

REVIEWED BY:

Anthony J. De Nova III

COUNTY ADMINISTRATOR

APPROVED AS TO FORM AND LEGALITY:

Matthew P. Jordan, Esq.

COUNTY COUNSEL

Planning and Economic Development

COMMITTEE NAME

<b>Official Resolution#</b>	<b>R20210771</b>							
Meeting Date	08/10/2021							
Introduced Date	08/10/2021							
Adopted Date	08/10/2021							
Agenda Item	I-55							
CAF #								
Purchase Req. #								
Result	Adopted							
<b>COMMISSIONER</b>	<b>PRES.</b>	<b>ABS.</b>	<b>MOVE</b>	<b>SEC</b>	<b>AYE</b>	<b>NAY</b>	<b>ABST.</b>	<b>RECU.</b>
Lepore	✓				✓			
James	✓		✓		✓			
Akhter	✓			✓	✓			
Bartlett	✓				✓			
Best Jr.	✓				✓			
Duffy	✓				✓			
Lazzara	✓				✓			

PRES.= present ABS.= absent  
 MOVE= moved SEC= seconded  
 AYE= yes NAY= no ABST.= abstain  
 RECU.= recuse

**Dated: August 11, 2021**

**RESOLUTION AUTHORIZING A NO COST TIME EXTENSION FOR  
THE COMMUNITY DEVELOPMENT BLOCK GRANT PROGRAM FY  
2019 TOWNSHIP OF WEST MILFORD PROJECT TO PROVIDE  
AMERICANS WITH DISABILITIES ACT ACCESSIBILITY TO THE  
BATHROOM IN MUNICIPAL BUILDING NO. 1 UNTIL OCTOBER 31,  
2021**

**WHEREAS**, the Passaic County Board of County Commissioners (hereafter “Board”) adopted Resolution R-2018-0536 on June 26, 2018, authorizing the submission of a Five (5) Year Consolidated Plan for the period of FY 2018-2022 to the US Department of Housing and Urban Development (hereafter “USHUD”) in compliance with the rules and regulations governing the Community Development Block Grant Program (hereafter “CDBG”); and

**WHEREAS**, the Board adopted the FY 2019 Annual Action Plan via Resolution R-2019-0591 on June 25, 2019; and

**WHEREAS**, the Board is cognizant of the conditions imposed by the USHUD and included a grant allocation in the FY 2019 Annual Action Plan to the Township of West Milford (hereafter “Township”) for \$35,000 to implement the Americans with Disabilities Act Accessibility project to the West Milford bathroom located in Municipal Building No. 1; and

**WHEREAS**, the Township has notified the Division of Economic Development, see attached correspondence, that the Township has been delayed in the implementation of the project due to the COVID-19 pandemic and is requesting that the CDBG FY 2019 grant award be extended to October 31, 2021 to permit the Township to complete the project; and

**WHEREAS**, this matter was discussed at the July 29, 2021 meeting of the County Commissioner Planning and Economic Development Committee and is being recommended to the Board for approval; and

**WHEREAS**, the Board considers this matter to be a benefit to the community and its residents;

**NOW THEREFORE BE IT RESOLVED** by the Board of County Commissioners of the County of Passaic that it hereby authorizes the no-cost grant extension of the Community Development Block Grant Program FY 2019 grant to the Township of West Milford to October 31, 2021 as set forth above; and

**LET IT BE FURTHER RESOLVED**, that the County of Passaic Commissioner Director and the Director of Economic Development are hereby authorized to act as the authorized representative of the County to execute all necessary documents and certifications on behalf of the County of Passaic.

JDP

Dated: August 10, 2021



## Township of West Milford

Office of the Township Administrator  
1480 Union Valley Road  
West Milford, NJ 07480-1303  
Phone: (973) 728-2710  
Fax: (973) 728-2884

July 19, 2021

Deborah Hoffman  
Director of Economic Development  
Passaic County Department of Planning & Economic Development  
930 Riverview Drive, Suite 250  
Totowa, NJ 07512-1167

**RE: 2019 Community Development Block Grant (CDBG) Program**

Dear Ms. Hoffman:

As you are aware, the Township awarded a construction contract, by resolution, for the Renovations and Alterations to an Existing Toilet Room in Municipal Building #1 (Town Hall) project on May 5, 2021. The Contractor began work after the Notice to Proceed was executed and has continued to perform to the extents of the contract agreement. Due to an unavailability of product materials, the project is anticipated to continue beyond the August 31, 2021 deadline. Therefore, the Township is requesting a deadline time extension to October 31, 2021.

Thank you for your consideration of this request. If you have any questions, or require any additional information, please do not hesitate to contact Township staff as necessary.

Very truly yours,

William Senande  
Township Administrator

CC: MICHELE DALE, MAYOR  
CHARLES CARBONE, ENGINEERING  
ELLEN MAGBEAN, FINANCE  
DIANE CURCIO, CLERK'S OFFICE

Introduced on: August 10, 2021  
Adopted on: August 10, 2021  
Official Resolution#: R20210771

# County of Passaic Board of County Commissioners

OFFICE OF COUNTY COMMISSIONERS

Director Pasquale "Pat" Lepore  
Deputy Director Bruce James  
Assad R. Akhter  
John W. Bartlett  
Theodore O. Best, Jr.  
Terry Duffy  
Cassandra "Sandi" Lazzara

401 Grand Street  
Paterson, New Jersey 07505  
Tel: 973-881-4402  
Fax: 973-742-3746

Anthony J. De Nova III  
*Administrator*  
Matthew P. Jordan, Esq.  
*County Counsel*  
Louis E. Imhof, III, RMC  
*Clerk Of The Board*



## Public Meeting (Board Meeting)

Date: Aug 10, 2021 - 5:30 PM

Location: County Administration Building  
Webex - 220  
401 Grand Street  
Paterson, NJ 07505

Agenda: RESOLUTION AUTHORIZING A NO COST TIME EXTENSION FOR THE COMMUNITY DEVELOPMENT BLOCK GRANT PROGRAM FY 2019 BOROUGH OF BLOOMINGDALE PROJECT TO PROVIDE AMERICANS WITH DISABILITIES ACT ACCESSIBILITY ALONG UNION AVENUE UNTIL DECEMBER 31, 2021, ALL AS NOTED IN THE RESOLUTION.

THIS RESOLUTION WAS REQUESTED BY:

ECONOMIC DEVELOPMENT

REVIEWED BY:

Anthony J. De Nova III

COUNTY ADMINISTRATOR

APPROVED AS TO FORM AND LEGALITY:

Matthew P. Jordan, Esq.

COUNTY COUNSEL

Planning and Economic Development

COMMITTEE NAME

<b>Official Resolution#</b>	<b>R20210772</b>							
Meeting Date	08/10/2021							
Introduced Date	08/10/2021							
Adopted Date	08/10/2021							
Agenda Item	I-56							
CAF #								
Purchase Req. #								
Result	Adopted							
<b>COMMISSIONER</b>	<b>PRES.</b>	<b>ABS.</b>	<b>MOVE</b>	<b>SEC</b>	<b>AYE</b>	<b>NAY</b>	<b>ABST.</b>	<b>RECU.</b>
Lepore	✓				✓			
James	✓		✓		✓			
Akhter	✓			✓	✓			
Bartlett	✓				✓			
Best Jr.	✓				✓			
Duffy	✓				✓			
Lazzara	✓				✓			

PRES.= present ABS.= absent  
MOVE= moved SEC= seconded  
AYE= yes NAY= no ABST.= abstain  
RECU.= recuse

**Dated: August 11, 2021**

**RESOLUTION AUTHORIZING A NO COST TIME EXTENSION FOR  
THE COMMUNITY DEVELOPMENT BLOCK GRANT PROGRAM FY  
2019 BOROUGH OF BLOOMINGDALE PROJECT TO PROVIDE  
AMERICANS WITH DISABILITIES ACT ACCESSIBILITY ALONG  
UNION AVENUE UNTIL DECEMBER 31, 2021**

**WHEREAS**, the Passaic County Board of County Commissioners (hereafter “Board”) adopted Resolution R-2018-0536 on June 26, 2018, authorizing the submission of a Five (5) Year Consolidated Plan for the period of FY 2018-2022 to the US Department of Housing and Urban Development (hereafter “USHUD”) in compliance with the rules and regulations governing the Community Development Block Grant Program (hereafter “CDBG”); and

**WHEREAS**, the Board adopted the FY 2019 Annual Action Plan via Resolution R-2019-0591 on June 25, 2019; and

**WHEREAS**, the Board is cognizant of the conditions imposed by the USHUD and included a grant allocation in the FY 2019 Annual Action Plan to the Borough of Bloomingdale (hereafter “Borough”) for \$75,000 to implement the Americans with Disabilities Act Accessibility project along Union Avenue; and

**WHEREAS**, the Borough has notified the Division of Economic Development, see attached correspondence, that the Borough has been delayed in the implementation of the project due to the COVID-19 pandemic and is requesting that the CDBG FY 2019 grant award be extended to December 31, 2021 to permit the Borough time to complete the project; and

**WHEREAS**, this matter was discussed at the July 29, 2021 meeting of the County Commissioner Planning and Economic Development Committee and is being recommended to the Board for approval; and

**WHEREAS**, the Board considers this matter to be a benefit to the community and its residents;

**NOW THEREFORE BE IT RESOLVED** by the Board of County Commissioners of the County of Passaic that it hereby authorizes the no-cost grant extension of the Community Development Block Grant Program FY 2019 grant to the Borough of Bloomingdale to December 31, 2021 as set forth above; and

**LET IT BE FURTHER RESOLVED**, that the County of Passaic Commissioner Director and the Director of Economic Development are hereby authorized to act as the authorized representative of the County to execute all necessary documents and certifications on behalf of the County of Passaic.

JDP

Dated: August 10, 2021



## BOROUGH OF BLOOMINGDALE

101 HAMBURG TURNPIKE • BLOOMINGDALE, NEW JERSEY 07403  
(TEL) 973-838-0778 (FAX) 973-838-5115

July 7, 2021

Ms. Deborah Hoffman  
Director  
Division of Economic Development  
County of Passaic  
401 Grand Street, Room 417  
Paterson, NJ 07505

Re: Request for a No-Cost Time Extension for Borough of Bloomingdale CDBG FY 2019 project to December 31, 2021

Dear Ms. Hoffman:

I am requesting a no-cost time extension on the Borough of Bloomingdale CDBG FY 2019 Union Avenue ADA improvement project. We have just opened the bids and are awarding the project shortly. The contractor will most likely not complete the project by August 31, 2021 so we are requesting an extension to December 31, 2021. Please let me know if you need anything else from me or the town. I appreciate in advance your consideration in this matter.

Sincerely,

*Mike Sondermeyer*

Michael Sondermeyer  
Borough Administrator  
101 Hamburg Turnpike  
Bloomingdale, N.J. 07403  
Office: 973-838-0778 X-243  
Cell: 862-330-8238  
[Msondermeyer@bloomingdalenj.net](mailto:Msondermeyer@bloomingdalenj.net)

[www.bloomingdalenj.net](http://www.bloomingdalenj.net)

Introduced on: August 10, 2021  
Adopted on: August 10, 2021  
Official Resolution#: R20210772

7

# County of Passaic Board of County Commissioners

OFFICE OF COUNTY COMMISSIONERS

Director Pasquale "Pat" Lepore  
Deputy Director Bruce James  
Assad R. Akhter  
John W. Bartlett  
Theodore O. Best, Jr.  
Terry Duffy  
Cassandra "Sandi" Lazzara

401 Grand Street  
Paterson, New Jersey 07505  
Tel: 973-881-4402  
Fax: 973-742-3746

Anthony J. De Nova III  
*Administrator*  
Matthew P. Jordan, Esq.  
*County Counsel*  
Louis E. Imhof, III, RMC  
*Clerk Of The Board*



## Public Meeting (Board Meeting)

Date: Aug 10, 2021 - 5:30 PM

Location: County Administration Building  
Webex - 220  
401 Grand Street  
Paterson, NJ 07505

Agenda: RESOLUTION AUTHORIZING A FIRST NO COST TIME EXTENSION FOR THE COMMUNITY DEVELOPMENT BLOCK GRANT PROGRAM FY 2019 WOODLAND PARK LIBRARY AMERICANS WITH DISABILITIES ACT COMPLIANT BATHROOM PROJECT UNTIL DECEMBER 31, 2021, ALL AS NOTED IN THE RESOLUTION.

THIS RESOLUTION WAS REQUESTED BY:

ECONOMIC DEVELOPMENT

REVIEWED BY:

  
Anthony J. De Nova III

COUNTY ADMINISTRATOR

APPROVED AS TO FORM AND LEGALITY:

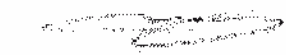
  
Matthew P. Jordan, Esq.

COUNTY COUNSEL

Planning and Economic Development

COMMITTEE NAME

<b>Official Resolution#</b>	<b>R20210773</b>							
Meeting Date	08/10/2021							
Introduced Date	08/10/2021							
Adopted Date	08/10/2021							
Agenda Item	I-57							
CAF #								
Purchase Req. #								
Result	Adopted							
<b>COMMISSIONER</b>	<b>PRES.</b>	<b>ABS.</b>	<b>MOVE</b>	<b>SEC</b>	<b>AYE</b>	<b>NAY</b>	<b>ABST.</b>	<b>RECU.</b>
Lepore	✓				✓			
James	✓		✓		✓			
Akhter	✓			✓	✓			
Bartlett	✓				✓			
Best Jr.	✓				✓			
Duffy	✓				✓			
Lazzara	✓				✓			

PRES.= present ABS.= absent  
MOVE= moved SEC= seconded  
AYE= yes NAY= no ABST.= abstain  
RECU.= recuse

Dated: August 11, 2021

**RESOLUTION AUTHORIZING A FIRST NO COST TIME EXTENSION  
FOR THE COMMUNITY DEVELOPMENT BLOCK GRANT  
PROGRAM FY 2019 WOODLAND PARK LIBRARY AMERICANS  
WITH DISABILITIES ACT COMPLIANT BATHROOM PROJECT  
UNTIL DECEMBER 31, 2021**

**WHEREAS**, the Passaic County Board of County Commissioners (hereafter “Board”) adopted Resolution R-2018-0536 on June 26, 2018, authorizing the submission of a Five (5) Year Consolidated Plan for the period of FY 2018-2022 to the US Department of Housing and Urban Development (hereafter “USHUD”) in compliance with the rules and regulations governing the Community Development Block Grant Program (hereafter “CDBG”); and

**WHEREAS**, the Board adopted the FY 2019 Annual Action Plan via Resolution R-2019-0591 on June 25, 2019; and

**WHEREAS**, the Board is cognizant of the conditions imposed by the USHUD and included a grant allocation in the FY 2019 Annual Action Plan to the Borough of Woodland Park (hereafter “Borough”) for \$60,000.00 to implement the Woodland Park Library Americans with Disabilities Act Compliant Bathroom Project; and

**WHEREAS**, the Borough has notified the Division of Economic Development, see attached correspondence, that the Borough has been delayed in the implementation of the project due to a significant delay in the award of a NJ State matching grant for the project and is requesting that the CDBG FY 2019 grant award be extended for the first time to December 31, 2021 to permit the Borough to complete the project; and

**WHEREAS**, this matter was discussed at the July 29, 2021 meeting of the County Commissioner Planning and Economic Development Committee and is being recommended to the Board for approval; and

**WHEREAS**, the Board considers this matter to be a benefit to the community and its residents;

**NOW THEREFORE BE IT RESOLVED** by the Board of County Commissioners of the County of Passaic that it hereby authorizes the first no-cost time extension of the Community Development Block Grant Program FY 2019 grant to the Borough of Woodland Park to December 31, 2021 as set forth above; and

**LET IT BE FURTHER RESOLVED**, that the County of Passaic Commissioner Director and Director of Economic Development are hereby authorized to act as the authorized representatives of the County to execute all necessary documents and certifications on behalf of the County of Passaic.

JDP

Dated: August 10, 2021





# *Borough of Woodland Park*

*Office of the Mayor*

**Keith Kazmark**  
Mayor

Passaic County, NJ  
5 Brophy Lane  
Woodland Park, NJ 07424  
Office: (973) 345-8100 x 210  
Fax: (973) 345-8194  
Home: (973) 684-3604  
Cell: (973) 420-9962  
E-Mail: [kkazmark@wpnj.us](mailto:kkazmark@wpnj.us)

Deborah Hoffman  
Division Director  
Economic Development Div.  
County of Passaic  
930 Riverview Dr., Suite 250  
Totowa, NJ 07512

July 19, 2021

Director Hoffman:

Regarding your e-mail correspondence of July 13, 2021, the Borough of Woodland Park respectfully requested an extension of the deadline for the following Community Development Block Grant, specifically:

- **CDBG FY 2019: Woodland Park Alfred H. Baumann Free Public Library ADA Compliant Bathrooms: \$60,000**

As you are aware, the Alfred H. Baumann Library has applied for the New Jersey Library Construction grant and those awards should be announced by the end of September. Should the Library be awarded the grant, we would like to use the above CDBG grant in tandem with the library grant.

We are requesting the funds be extended beyond the December 31, 2021 timeframe, as we are truly trying to improve the public library with multiple grant initiatives.

Please advise if you need anything more.

Sincerely,

Keith Kazmark  
Mayor

KK:tm

CC: Linda Hoffman, Alfred H. Baumann Free Public Library

Introduced on: August 10, 2021  
Adopted on: August 10, 2021  
Official Resolution#: R20210773

00

# County of Passaic Board of County Commissioners

OFFICE OF COUNTY COMMISSIONERS

Director Pasquale "Pat" Lepore  
Deputy Director Bruce James  
Assad R. Akhter  
John W. Bartlett  
Theodore O. Best, Jr.  
Terry Duffy  
Cassandra "Sandi" Lazzara

401 Grand Street  
Paterson, New Jersey 07505  
Tel: 973-881-4402  
Fax: 973-742-3746

Anthony J. De Nova III  
*Administrator*  
Matthew P. Jordan, Esq.  
*County Counsel*  
Louis E. Imhof, III, RMC  
*Clerk Of The Board*



## Public Meeting (Board Meeting)

Date: Aug 10, 2021 - 5:30 PM

Location: County Administration Building  
Webex - 220  
401 Grand Street  
Paterson, NJ 07505

Agenda: RESOLUTION AUTHORIZING A NO-COST TIME EXTENSION TO 2019 ROUND OF MUNICIPAL AND NON-PROFIT GRANTS FROM THE OPEN SPACE, FARMLAND, AND HISTORIC PRESERVATION TRUST FUND PROGRAM TO THE WAYNE LITTLE LEAGUE, DOTTERWEICH FIELD AND FACILITY IMPROVEMENTS TO ACCOUNT FOR THE IMPACTS OF COVID-19 AND THE SIGNIFICANT MATERIAL COST INCREASES, ALL AS NOTED IN THE RESOLUTION.

THIS RESOLUTION WAS REQUESTED BY:

PLANNING BOARD

REVIEWED BY:

Anthony J. De Nova III  
COUNTY ADMINISTRATOR

APPROVED AS TO FORM AND LEGALITY:

Matthew P. Jordan, Esq.  
COUNTY COUNSEL

Planning and Economic Development  
COMMITTEE NAME

<b>Official Resolution#</b>	<b>R20210774</b>							
Meeting Date	08/10/2021							
Introduced Date	08/10/2021							
Adopted Date	08/10/2021							
Agenda Item	I-58							
CAF #								
Purchase Req. #								
Result	Adopted							
<b>COMMISSIONER</b>	<b>PRES.</b>	<b>ABS.</b>	<b>MOVE</b>	<b>SEC</b>	<b>AYE</b>	<b>NAY</b>	<b>ABST.</b>	<b>RECU.</b>
Lepore	✓				✓			
James	✓		✓		✓			
Akhter	✓			✓	✓			
Bartlett	✓				✓			
Best Jr.	✓				✓			
Duffy	✓				✓			
Lazzara	✓				✓			

PRES.= present ABS.= absent  
 MOVE= moved SEC= seconded  
 AYE= yes NAY= no ABST.= abstain  
 RECU.= recuse

Dated: August 11, 2021

**RESOLUTION AUTHORIZING A NO-COST TIME EXTENSION TO 2019 ROUND OF MUNICIPAL AND NON-PROFIT GRANTS FROM THE OPEN SPACE, FARMLAND, AND HISTORIC PRESERVATION TRUST FUND PROGRAM TO THE WAYNE LITTLE LEAGUE, DOTTERWEICH FIELD AND FACILITY IMPROVEMENTS TO ACCOUNT FOR THE IMPACTS OF COVID-19 AND THE SIGNIFICANT MATERIAL COST INCREASES.**

**WHEREAS**, the Board of County Commissioners of the County of Passaic (hereafter “Board”) created an Open Space, Farmland and Historic Preservation Trust Fund Program (hereafter “Program”) in conformity with the will of the voters in the 1996 election, as authorized by N.J.S.A. 40:12-15.2; and

**WHEREAS**, the purpose and goals of the above is to achieve, in partnership with others, a system of interconnected open spaces, whose protection will preserve and enhance New Jersey’s natural environment and its historic, scenic, and recreational resources for public use and enjoyment; and

**WHEREAS**, pursuant to Resolution R2019-0588, dated June 25, 2019, the Board awarded funding under the 2019 round of Municipal and Non-Profit grants from the Program for the Wayne Little League, Dotterweich Field and Facility Improvements; and

**WHEREAS**, the grant funds of \$50,000.00 are to be used for ongoing improvements to this municipal little league facility; and

**WHEREAS**, pursuant to the Program Rules and Regulations (hereafter “Rules”) promulgated by the Board, specifically Chapter 11, Paragraph 1(a), the Project Agreement requires a two (2) year project term whereby all Program monies must be distributed; and

**WHEREAS**, pursuant to the said Rules, the date of execution of the Project Agreement shall begin the two (2) year clock on the project, and the time period presently is due to end forthwith; and

**WHEREAS**, the President of Wayne Little League has requested a project extension (copy attached) since fencing material prices increased significantly as a result of the pandemic, and they now have approximately \$31,025.30 to be used to purchase new fencing, with the project expected to be completed by December 31, 2021; and

**WHEREAS**, the Board is desirous of authorizing a no-cost extension to the Wayne Little League, Dotterweich Field and Facility Improvements, grant from the Program until December 31, 2021 to account for the impacts of COVID-19 and the significant material cost increases; and

**WHEREAS**, this matter was reviewed and discussed at the July 29, 2021 meeting of the Planning and Economic Development Committee and being recommended to the Board for approval; and

**NOW THEREFORE, LET IT BE RESOLVED** that the Board of County Commissioners of the County of Passaic authorize an extension to the 2019 round of Municipal and Non-Profit grants from the Open Space, Farmland, and Historic Preservation Trust Fund to the Wayne Little League, Dotterweich Field and Facility Improvements until December 31, 2021 to account for the impacts of COVID-19 and the significant material cost increases; and

**LET IT BE FURTHER RESOLVED** that the Director and Clerk are hereby authorized to execute the necessary agreements to effectuate the extension referenced above.

JDP

Dated: August 10, 2021

# Wayne Little League

---

11 Copley Court, Wayne, New Jersey 07470

07/26/21

Jessie Summers, PLA  
Passaic County Department of Planning & Economic Development  
401 Grand Street, Room 417  
Paterson, New Jersey 07505

**Dear Jessie Summers, PLA :**

Please accept this letter as a request to extend our 2019 grant balance.

We currently have an existing balance of \$31,025.30. This money is going to be used with the 2020-2021 grant money we were awarded to purchase new fencing for one of our fields, D1.

We held off on this project because fencing material prices went up significantly as a result of the pandemic. We are planning on starting this project in the fall and expect to have it completed by year end.

Please let me know if you need anything else from me.

Sincerely,

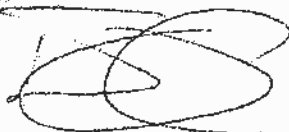

---

**Tim Crowe, President Wayne Little League**

# County of Passaic Board of County Commissioners

OFFICE OF COUNTY COMMISSIONERS

Director Pasquale "Pat" Lepore  
Deputy Director Bruce James  
Assad R. Akhter  
John W. Bartlett  
Theodore O. Best, Jr.  
Terry Duffy  
Cassandra "Sandi" Lazzara

401 Grand Street  
Paterson, New Jersey 07505  
Tel: 973-881-4402  
Fax: 973-742-3746

Anthony J. De Nova III  
*Administrator*  
Matthew P. Jordan, Esq.  
*County Counsel*  
Louis E. Imhof, III, RMC  
*Clerk Of The Board*



## Public Meeting (Board Meeting)

Date: Aug 10, 2021 - 5:30 PM

Location: County Administration Building  
Webex - 220  
401 Grand Street  
Paterson, NJ 07505

Agenda: RESOLUTION AUTHORIZING A NO-COST TIME EXTENSION TO 2017 ROUND OF MUNICIPAL AND NON-PROFIT GRANTS FROM THE OPEN SPACE, FARMLAND, AND HISTORIC PRESERVATION TRUST FUND PROGRAM TO THE BOROUGH OF HALEDON, BRAEN MEMORIAL/ROE STREET FIELD, DUE TO BID EXCEEDING PROJECT ESTIMATE, ALL AS NOTED IN THE RESOLUTION.

THIS RESOLUTION WAS REQUESTED BY:

PLANNING BOARD

REVIEWED BY:

Anthony J. De Nova III

COUNTY ADMINISTRATOR

APPROVED AS TO FORM AND LEGALITY:

Matthew P. Jordan, Esq.

COUNTY COUNSEL

Planning and Economic Development

COMMITTEE NAME

<b>Official Resolution#</b>	<b>R20210775</b>							
Meeting Date	08/10/2021							
Introduced Date	08/10/2021							
Adopted Date	08/10/2021							
Agenda Item	I-59							
CAF #								
Purchase Req. #								
Result	Adopted							
<b>COMMISSIONER</b>	<b>PRES.</b>	<b>ABS.</b>	<b>MOVE</b>	<b>SEC</b>	<b>AYE</b>	<b>NAY</b>	<b>ABST.</b>	<b>RECU.</b>
Lepore	✓				✓			
James	✓		✓		✓			
Akhter	✓			✓	✓			
Bartlett	✓				✓			
Best Jr.	✓				✓			
Duffy	✓				✓			
Lazzara	✓				✓			

PRES.= present ABS.= absent  
MOVE= moved SEC= seconded  
AYE= yes NAY= no ABST.= abstain  
RECU.= recuse

**Dated: August 11, 2021**

**RESOLUTION AUTHORIZING A NO-COST TIME EXTENSION TO 2017 ROUND OF MUNICIPAL AND NON-PROFIT GRANTS FROM THE OPEN SPACE, FARMLAND, AND HISTORIC PRESERVATION TRUST FUND PROGRAM TO THE BOROUGH OF HALEDON, BRAEN MEMORIAL/ROE STREET FIELD, DUE TO BID EXCEEDING PROJECT ESTIMATE.**

**WHEREAS**, the Board of County Commissioners of the County of Passaic (hereafter “Board”) created an Open Space, Farmland and Historic Preservation Trust Fund Program (hereafter “Program”) in conformity with the will of the voters in the 1996 election, as authorized by N.J.S.A. 40:12-15.2; and

**WHEREAS**, the purpose and goals of the above is to achieve, in partnership with others, a system of interconnected open spaces, whose protection will preserve and enhance New Jersey’s natural environment and its historic, scenic, and recreational resources for public use and enjoyment; and

**WHEREAS**, pursuant to Resolution R2017-0566, dated June 27, 2017, the Board awarded funding under the 2017 round of Municipal and Non-Profit grants from the Program for the Haledon – Roc Athletic Field Signage and Landscaping Improvements project; and

**WHEREAS**, the grant funds of \$40,800.00 are to be used for site improvements, including low level lighting, signage, and security netting at the site; and

**WHEREAS**, pursuant to the Program Rules and Regulations (hereafter “Rules”) promulgated by the Board, specifically Chapter 11, Paragraph 1(a), the Project Agreement requires a two (2) year project term whereby all Program monies must be distributed; and

**WHEREAS**, pursuant to the said Rules, the date of execution of the Project Agreement shall begin the two (2) year clock on the project, and the time period presently is due to end forthwith; and

**WHEREAS**, the grant was initially scheduled to be completed by September 29, 2019, which was subsequently extended by the Board through October, 2020 by way of Resolution R-2019-0916; and

**WHEREAS**, the Municipal Clerk/Administrator of the Borough of Haledon (hereafter “Borough”) has requested another project extension (copy attached) to June 1, 2022, since the initial bid exceeded the engineer’s project estimate, and the governing body of the Borough has authorized the re-advertisement for new bids in the fall with a spring 2022 completion; and

**WHEREAS**, the Board is desirous of authorizing a no-cost extension to the Borough until June 1, 2022 to account for the rejected bid and anticipated re-advertisement and bidding on the Project; and

**WHEREAS**, this matter was reviewed and discussed at the July 29, 2021 meeting of the Planning and Economic Development Committee and being recommended to the Board for approval; and

**NOW THEREFORE, LET IT BE RESOLVED** that the Board of County Commissioners of the County of Passaic authorize another extension to the 2017 round of Municipal and Non-Profit grants from the Open Space, Farmland, and Historic Preservation Trust Fund to the Haledon – Roc Athletic Field Signage and Landscaping Improvements project, until June 1, 2022, to account for the re-advertisement and re-bidding on the project; and

**LET IT BE FURTHER RESOLVED** that the Director and Clerk are hereby authorized to execute the necessary agreements to effectuate the extension referenced above.

JDP

Dated: August 10, 2021

# BOROUGH OF HALEDON

*A Pioneer Community*



DOMENICK STAMPONE  
MAYOR

ALLAN R. SUSEN, RMC/MMC  
MUNICIPAL CLERK/ADMINISTRATOR

TELEPHONE: 973-595-7766 EXT. 103  
FACSIMILE: 973-790-4781

July 26, 2021

Passaic County Dept of Planning and Economic Development  
Attn: Michael Lysicatos AICP, PP  
401 Grand Street, Room 417  
Paterson, NJ 07505

Dear Mr. Lysicatos:

The Borough of Haledon recently solicited bids for improvements to the Braen Memorial/Roe Street Field which includes low level lighting, signage, and security netting. Only one bid was received with a price double the Engineer's estimate. The Governing Body rejected the bid at their July 22, 2021 meeting.

In his recommendation letter to reject the bid, our Borough Engineer suggested the Mayor and Council wait until this Fall to rebid the project for a Spring 2022 completion. Therefore, I am requesting that the County Commissioners grant an extension to June 1, 2022. Bidding the project in the Fall with a Spring 2022 startup and completion should provide for better pricing.

Thank you for your consideration.

Respectfully,

Allan R. Susen, RMC/MMC  
Municipal Clerk/Administrator

# County of Passaic Board of County Commissioners

OFFICE OF COUNTY COMMISSIONERS

Director Pasquale "Pat" Lepore  
Deputy Director Bruce James  
Assad R. Akhter  
John W. Bartlett  
Theodore O. Best, Jr.  
Terry Duffy  
Cassandra "Sandi" Lazzara

401 Grand Street  
Paterson, New Jersey 07505  
Tel: 973-881-4402  
Fax: 973-742-3746

Anthony J. De Nova III  
*Administrator*  
Matthew P. Jordan, Esq.  
*County Counsel*  
Louis E. Imhof, III, RMC  
*Clerk Of The Board*



## Public Meeting (Board Meeting)

Date: Aug 10, 2021 - 5:30 PM

Location: County Administration Building  
Webex - 220  
401 Grand Street  
Paterson, NJ 07505

Agenda: RESOLUTION AUTHORIZING AN APPLICATION BY THE COUNTY OF PASSAIC TO THE NEW JERSEY TRANSPORTATION PLANNING AUTHORITY FY23-24 SUBREGIONAL STUDIES PROGRAM GRANT FOR THE PASSAIC COUNTY INFRASTRUCTURE INVESTMENT PLAN FOR \$375,000.00 WITH A CASH MATCH OF \$75,000.00, ALL AS NOTED IN THE RESOLUTION.

THIS RESOLUTION WAS REQUESTED BY:

PLANNING BOARD

REVIEWED BY:

  
Anthony J. De Nova III

COUNTY ADMINISTRATOR

APPROVED AS TO FORM AND LEGALITY:

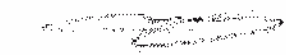
  
Matthew P. Jordan, Esq.

COUNTY COUNSEL

Planning and Economic Development

COMMITTEE NAME

<b>Official Resolution#</b>	<b>R20210776</b>							
Meeting Date	08/10/2021							
Introduced Date	08/10/2021							
Adopted Date	08/10/2021							
Agenda Item	I-60							
CAF #								
Purchase Req. #								
Result	Adopted							
<b>COMMISSIONER</b>	<b>PRES.</b>	<b>ABS.</b>	<b>MOVE</b>	<b>SEC</b>	<b>AYE</b>	<b>NAY</b>	<b>ABST.</b>	<b>RECU.</b>
Lepore	✓				✓			
James	✓		✓		✓			
Akhter	✓			✓	✓			
Bartlett	✓				✓			
Best Jr.	✓				✓			
Duffy	✓				✓			
Lazzara	✓				✓			

PRES.= present ABS.= absent  
 MOVE= moved SEC= seconded  
 AYE= yes NAY= no ABST.= abstain  
 RECU.= recuse

**Dated: August 11, 2021**



**RESOLUTION AUTHORIZING AN APPLICATION BY THE COUNTY OF PASSAIC TO THE NEW JERSEY TRANSPORTATION PLANNING AUTHORITY FY23-24 SUBREGIONAL STUDIES PROGRAM GRANT FOR THE PASSAIC COUNTY INFRASTRUCTURE INVESTMENT PLAN FOR \$375,000.00 WITH A CASH MATCH OF \$75,000.00.**

**WHEREAS**, the County of Passaic (hereafter “County”) is a body politic and corporate pursuant to N.J.S.A. 40:18-1 and vested with all rights contained therein; and

**WHEREAS**, pursuant to N.J.S.A. 40:20-1, the Board of County Commissioners of the County of Passaic (hereafter “Board”) is vested with managing the property, finances, and affairs of the County; and

**WHEREAS**, the Planning and Economic Development Division (hereafter “Division”) is recommending that the County apply for a grant from the New Jersey Transportation Planning Authority (hereafter “NJTPA”) FY23-24 Subregional Studies Program for the Passaic County Strategic Infrastructure Investment Plan, Comprehensive Economic Development Strategy (hereafter “Plan”) for the period from July 1, 2022 to June 30, 2024; and

**WHEREAS**, the study will marry work already done through our Plan and the various technical studies and recommendations put forward by State, County and local plans for infrastructure to target investments that will have the largest economic impact to Passaic County; and

**WHEREAS**, the Plan will identify 6 – 10 priority investment areas that will be the road map for programming infrastructure funding and also bring together work of the Division in an actionable plan; and

**WHEREAS**, the Plan is a continuation of the ongoing effort for improvement and expansion of public infrastructure in the County; and

**WHEREAS**, the request is for a Three Hundred Seventy-Five Thousand (\$375,000.00) Dollar grant; and

**WHEREAS**, the County shall provide a cash match of Seventy-Five Thousand (\$75,000.00) Dollars required by the NJTPA program; and

**WHEREAS**, the matter was discussed at the July 28, 2021, meeting of the Planning and Economic Development Committee and is being recommended to the Board for approval; and

**NOW THEREFORE, LET IT BE RESOLVED**, that the Board of County Commissioners of the County of Passaic (hereafter “Board”) authorizes a grant application to the New Jersey Transportation Planning Authority’s FY23-24 Subregional Studies Program for the Passaic County Strategic Infrastructure Investment Plan in the amount of Three Hundred Seventy-Five Thousand (\$375,000.00) Dollars with a cash match of Seventy-Five Thousand (\$75,000.00) Dollars; and

**LET IT BE FURTHER RESOLVED**, the Clerk to the Board, County Counsel, the Director of Planning and Economic Development, and Director of the Board are authorized to take any other steps necessary to carry out the purpose of this Resolution.

JDP

August 10, 2021

# County of Passaic Board of County Commissioners

OFFICE OF COUNTY COMMISSIONERS

Director Pasquale "Pat" Lepore  
Deputy Director Bruce James  
Assad R. Akhter  
John W. Bartlett  
Theodore O. Best, Jr.  
Terry Duffy  
Cassandra "Sandi" Lazzara

401 Grand Street  
Paterson, New Jersey 07505  
Tel: 973-881-4402  
Fax: 973-742-3746

Anthony J. De Nova III  
*Administrator*  
Matthew P. Jordan, Esq.  
*County Counsel*  
Louis E. Imhof, III, RMC  
*Clerk Of The Board*



## Public Meeting (Board Meeting)

Date: Aug 10, 2021 - 5:30 PM

Location: County Administration Building  
Webex - 220  
401 Grand Street  
Paterson, NJ 07505

Agenda: RESOLUTION AUTHORIZING PAYMENT TO GRAYSHIFT, LLC FOR THE PURCHASE OF FORENSIC SOFTWARE TO BE USED BY THE PASSAIC COUNTY PROSECUTOR'S OFFICE, PURSUANT TO N.J.S.A. 40A:11-5, ET SEQ., ALL AS NOTED IN THE RESOLUTION.

THIS RESOLUTION WAS REQUESTED BY:  
PROSECUTOR'S OFFICE

REVIEWED BY:

Anthony J. De Nova III  
COUNTY ADMINISTRATOR

APPROVED AS TO FORM AND LEGALITY:

Matthew P. Jordan, Esq.  
COUNTY COUNSEL

Late Starters

COMMITTEE NAME

<b>Official Resolution#</b>	<b>R20210777</b>							
Meeting Date	08/10/2021							
Introduced Date	08/10/2021							
Adopted Date	08/10/2021							
Agenda Item	I-61							
CAF #								
Purchase Req. #								
Result	Adopted							
<b>COMMISSIONER</b>	<b>PRES.</b>	<b>ABS.</b>	<b>MOVE</b>	<b>SEC</b>	<b>AYE</b>	<b>NAY</b>	<b>ABST.</b>	<b>RECU.</b>
Lepore	✓				✓			
James	✓		✓		✓			
Akhter	✓			✓	✓			
Bartlett	✓				✓			
Best Jr.	✓				✓			
Duffy	✓				✓			
Lazzara	✓				✓			

PRES.= present ABS.= absent  
 MOVE= moved SEC= seconded  
 AYE= yes NAY= no ABST.= abstain  
 RECU.= recuse

Dated: August 11, 2021

**RESOLUTION AUTHORIZING PAYMENT TO GRAYSHIFT, LLC FOR THE PURCHASE OF FORENSIC SOFTWARE TO BE USED BY THE PASSAIC COUNTY PROSECUTOR'S OFFICE, PURSUANT TO N.J.S.A. 40A:11-5, ET SEQ.**

**WHEREAS**, the County of Passaic (hereafter "County") is a body politic and corporate pursuant to N.J.S.A. 40:18-1 and vested with all rights contained therein; and

**WHEREAS**, pursuant to N.J.S.A. 40:20-1 the Board of County Commissioners of the County of Passaic (hereafter "Board") is vested with managing the property, finances, and affairs of the County; and

**WHEREAS**, pursuant to N.J.S.A. 40A:11-5(dd), any contract the amount of which exceeds the bid threshold, may be negotiated and awarded by the governing body without public advertising for bids and bidding therefor and shall be awarded by resolution of the governing body if it is for the provision or performance of goods or services for the support or maintenance of proprietary computer hardware and software, except that this provision shall not be utilized to acquire or upgrade non-proprietary hardware or to acquire or update non-proprietary software; and

**WHEREAS**, on June 30, 2020 the Board approved Resolution No. R20200514 setting the bid threshold at forty-four thousand dollars (\$44,000.00), in accordance with the law; and

**WHEREAS**, Grayshift, LLC (hereinafter "Grayshift") provides maintenance for specialized computer software which is used by the Passaic County Prosecutor's Office (hereinafter PCPO); and

**WHEREAS**, the PCPO is seeking authorization to render payment to Grayshift in an amount not to exceed eighteen thousand dollars (\$18,000) for purchase of forensic software; and

**WHEREAS**, Grayshift executed and notarized the County's Business Entity Disclosure Certification for non-fair and open contracts required pursuant to N.J.S.A. 19:44A-20.8, which is attached to and made part of this Resolution; and

**WHEREAS**, funds are available in Account No. 1-01-20-109-001-239 or any other account that may be deemed appropriate by the Chief Financial Officer or his designee, and the availability of funds has been contingently certified by the Chief Financial Officer subject to sufficient funds being appropriated by the Board in the 2021 and/or subsequent years' County budget(s), which is attached to and made part of this Resolution; and

**WHEREAS**, this matter was discussed at Law and Public Safety Committee meeting on August 3, 2021 and is being recommended to the Board for approval; and

**NOW, THEREFORE, LET IT BE RESOLVED**, pursuant to N.J.S.A. 40A:11-5, et seq. that the Board of County Commissioners of the County of Passaic authorizes payment to Grayshift, LLC in an amount not to exceed eighteen thousand dollars (\$18,000) for the purchase of specialized forensic software to be used by the Passaic County Prosecutor's Office.

**LET IT BE FURTHER RESOLVED**, the Clerk of the Board shall print, in the official newspaper, a brief notice stating the nature, duration, service, and amount of the contract to Grayshift, LLC, and maintain a copy of the resolution on file and available for public inspection in the Office of the Clerk to the Board.

**LET IT BE FURTHER RESOLVED**, that the Clerk of the Board, County Counsel, and the Director of the Board are authorized to take any other steps necessary to carry out the purpose of this resolution.

LSP

August 10, 2021



# BUSINESS ENTITY DISCLOSURE CERTIFICATION

FOR NON-FAIR AND OPEN CONTRACTS  
Required Pursuant To N.J.S.A. 19:44A-20.8  
COUNTY OF PASSAIC

**Part I - Vendor Affirmation**

The undersigned, being authorized and knowledgeable of the circumstance, does hereby certify that the Grayshift, LLC has not made and will not make any reportable contributions pursuant to N.J.S.A. 19:44A-1 et seq, that pursuant to P.L. 2004, c. 19 would bar the award of this contract in the one-year period proceeding August 10, 2021 to any of the following name candidates committee, joint candidates committees and political party committees representing the elected officials of the Passaic County Board of Commissioners as defined pursuant to N.J.S.A. 19:44A-3(p), (q) and (r)

Bruce James for Freeholder	Sandil Lazzara for Freeholder
Friends of Assad Akther	Friends of Danielle Ireland-Ianhol
Friends of John Bartlett for Freeholder	Friends of Toledo for Surrogate
Friends of Terry Duffy	Friends of Berdnik for Sheriff
Friends of Theodore Best for Freeholder	
Passaic County Democratic Committee	

**Part II - Ownership Disclosure Certification**

I certify that the list below contains the names and home addresses of all owners holding 10% or more of the issued and outstanding stock of the undersigned.

Check the box that represents the type of business entity:

- Partnership     
  Corporation     
  Sole Proprietorship     
  Subchapter S Corporation  
 Limited Partnership     
  Limited Liability Corporation     
  Limited Liability Partnership

Name of Stock or Shareholder	Home Address
David Miles	1110 Woodcreek Ct Peachtree City, GA 30269
Mark Snell	1050 Stonegrove Lane Roswell, GA 30075
Justin Fisher	221 Indian Hills Court Marietta, GA 30068
Sean Larsson	426 Bantam Lake Rd Bantam, CT 06750
Braden Thomas	507 Etris Ct Roswell, GA 30075
Peak Equity Partners	355 East Lancaster Ave Ste 500 Radnor, PA 19087

**Part 3 - Signature and Attestation**

The undersigned is fully aware that if I have misrepresented in whole or part this affirmation and certification, I and/or the business entity, will be liable for any penalty permitted under law.

Name of Business Entity: Grayshift, LLC  
 Signed: [Signature] Title: Chief Financial Officer  
 Printed Name: Mark Snell Date: 8/10/2021

Subscribed and sworn before me this 10 day of August, 2021.

My Commission expires: 8/12/2023

[Signature]  
 (Affiant)  
Sandil Lazzara  
 (Print name & title of affiant) (Corporate Seal)

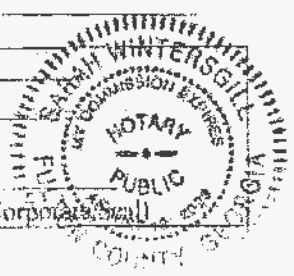

CERTIFICATION OF AVAILABLE FUNDS

THIS IS TO CERTIFY THAT FUNDS ARE AVAILABLE AS FOLLOWS:

AMOUNT: \$18,000.00

APPROPRIATION: 1-01-20-109-001-239

PURPOSE: Resolution awarding a contract to Grayshift, LLC  
For the purchase of forensic software to be used  
By the Prosecutor's office



Richard Cahill, Director of Finance

DATED: August 10, 2021

Introduced on: August 10, 2021  
Adopted on: August 10, 2021  
Official Resolution#: R20210777

# County of Passaic Board of County Commissioners

OFFICE OF COUNTY COMMISSIONERS

Director Pasquale "Pat" Lepore  
Deputy Director Bruce James  
Assad R. Akhter  
John W. Bartlett  
Theodore O. Best, Jr.  
Terry Duffy  
Cassandra "Sandi" Lazzara

401 Grand Street  
Paterson, New Jersey 07505

Tel: 973-881-4402  
Fax: 973-742-3746

Anthony J. De Nova III  
*Administrator*

Matthew P. Jordan, Esq.  
*County Counsel*

Louis E. Imhof, III, RMC  
*Clerk Of The Board*



## Public Meeting (Board Meeting)

Date: Aug 10, 2021 - 5:30 PM

Location: County Administration Building  
Webex - 220  
401 Grand Street  
Paterson, NJ 07505

Agenda: RESOLUTION AUTHORIZING AN APPLICATION TO THE US DEPARTMENT OF INTERIOR OUTDOOR RECREATION LEGACY GRANT PROGRAM FOR THE NORTH PULASKI PARK RENOVATION PROJECT, PURSUANT TO N.J.S.A. 40:20-1, ALL AS NOTED IN THE RESOLUTION.

THIS RESOLUTION WAS REQUESTED BY:

PLANNING BOARD

REVIEWED BY:

  
Anthony J. De Nova III

COUNTY ADMINISTRATOR

APPROVED AS TO FORM AND LEGALITY:

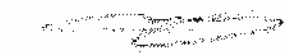
  
Matthew P. Jordan, Esq.

COUNTY COUNSEL

Late Starters

COMMITTEE NAME

<b>Official Resolution#</b>	<b>R20210778</b>							
Meeting Date	08/10/2021							
Introduced Date	08/10/2021							
Adopted Date	08/10/2021							
Agenda Item	I-62							
CAF #								
Purchase Req. #								
Result	Adopted							
<b>COMMISSIONER</b>	<b>PRES.</b>	<b>ABS.</b>	<b>MOVE</b>	<b>SEC</b>	<b>AYE</b>	<b>NAY</b>	<b>ABST.</b>	<b>RECU.</b>
Lepore	✓				✓			
James	✓		✓		✓			
Akhter	✓			✓	✓			
Bartlett	✓				✓			
Best Jr.	✓				✓			
Duffy	✓				✓			
Lazzara	✓				✓			

PRES.= present ABS.= absent  
MOVE= moved SEC= seconded  
AYE= yes NAY= no ABST.= abstain  
RECU.= recuse

Dated: August 11, 2021

**RESOLUTION AUTHORIZING AN APPLICATION TO THE US DEPARTMENT OF INTERIOR OUTDOOR RECREATION LEGACY GRANT PROGRAM FOR THE NORTH PULASKI PARK RENOVATION PROJECT, PURSUANT TO N.J.S.A. 40:20-1**

**WHEREAS**, the County of Passaic (hereafter “County”) is a body politic and corporate pursuant to N.J.S.A. 40:18-1 and vested with all rights contained therein; and

**WHEREAS**, pursuant to N.J.S.A. 40:20-1 the Board of County Commissioners for the County of Passaic (hereafter “Board”) is vested with managing the property, finances, and affairs of the County; and

**WHEREAS**, the United States Department of Interior is distributing \$150 million to local communities through the Outdoor Recreation Legacy Partnership Grant Program (hereafter “Grant Program”) that enables urban communities to create new outdoor recreation spaces, reinvigorate existing parks, and form connections between people and the outdoors in economically underserved communities; and

**WHEREAS**, the County, in partnership with the City of Passaic and Trust for Public Land, are renovating North Pulaski Park in the City of Passaic, as part of the Dundee Island Phase II Improvement Project (hereafter “Project”), to renovate and enhance a public neighborhood park with various amenities; and

**WHEREAS**, the Board is seeking to apply for three million three hundred forty nine thousand three hundred sixty eight dollars and ninety four cents (\$3,349,368.94) from the Grant Program, to fund the construction of the Project; and

**WHEREAS**, if awarded, the Board shall allocate the appropriate matching funds required by the Grant Program on a 1:1 basis in the amount of three million three hundred forty nine thousand three hundred sixty eight dollars and ninety four cents (\$3,349,368.94); and

**WHEREAS**, this matter was discussed by the Planning and Economic Development Committee, and is being recommended to the Board for approval; and

**NOW, THEREFORE, LET IT BE RESOLVED**, pursuant to the N.J.S.A. 40:20-1 that the Board of County Commissioners for the County of Passaic authorizes an application to the United State Department of Interior Outdoor Recreation Legacy Grant Program in the amount of three million three hundred forty nine thousand three hundred sixty eight dollars and ninety four cents (\$3,349,368.94) for renovations to North Pulaski Park in the City of Passaic, as part of the Dundee Island Phase II Improvement Project.

**LET IT BE FURTHER RESOLVED** if the funding is received by the County, the Board of County Commissioners shall allocate the appropriate matching funds in the amount of three million three hundred forty nine thousand three hundred sixty eight dollars and ninety four cents (\$3,349,368.94) to fund the construction of the Project.

**LET IT BE FURTHER RESOLVED** that the Clerk of the Board, County Counsel, County Administrator, Director of the Department of Planning and Economic Development, Chief Financial Officer, and any other official as designated by the County Administrator are authorized to take any action in furtherance of completing the grant application and in furtherance of this Resolution.

MPJ

August 10, 2021

## **PUBLIC NOTICE**

**PLEASE TAKE NOTICE:** The Board of County Commissioners of the County of Passaic adopted Resolution No. R20210001 at its January 7, 2021 meeting setting the regular meeting schedule for calendar year 2021 in compliance with N.J.S.A. 10:4-18 to take place at the following dates and times:

January 26, 2021 at 5:30 PM  
February 9, 2021 at 5:30 PM  
February 23, 2021 at 5:30 PM  
March 9, 2021 at 5:30 PM  
March 23, 2021 at 5:30 PM  
April 13, 2021 at 5:30 PM  
April 27, 2021 at 5:30 PM  
May 11, 2021 at 5:30 PM  
May 25, 2021 at 5:30 PM  
June 8, 2021 at 5:30 PM  
June 22, 2021 at 5:30 PM  
July 20, 2021 at 5:30 PM  
August 10, 2021 at 5:30 PM  
September 8, 2021 at 5:30 PM  
September 28, 2021 at 5:30 PM  
October 12, 2021 at 5:30 PM  
October 26, 2021 at 5:30 PM  
November 9, 2021 at 5:30 PM  
November 23, 2021 at 5:30 PM  
December 14, 2021 at 5:30 PM  
December 28, 2021 at 10:00 AM

Meetings of the Board shall be conducted using electronic equipment on Facebook Live and Cisco WebEx in compliance with the requirements and conditions as set forth in the N.J.S.A. 10:4-9.3, et seq. because of the Public Health Emergency declared by New Jersey Governor Phillip Murphy pursuant to Executive Order No. 103 and renewed thereafter by subsequent executive orders and in compliance with the Board's By-Laws. If a member of the public wishes to place a public comment on the record please email [public@passaiccountynj.org](mailto:public@passaiccountynj.org) stating your name, address, and matter to be addressed by the Board no later than 5:30 PM on the date of the scheduled meeting. The Clerk of the Board shall read same into the public record. Additionally, a member of the public may participate electronically via Cisco WebEx on the date of the meeting at <https://passaiccountynj.org/MeetingofCommissioners> and shall be afforded time to participate in the public portion of the meeting in compliance with the Board's By-Laws. Official action will be taken. This notice is being issued pursuant to the Open Public Meetings Act, P.L. 1975, Chapter 231, N.J.S.A. 10:4-06, et seq.

### **BY ORDER OF THE BOARD OF COUNTY COMMISSIONERS**

---

Louis E. Imhof III, Clerk of the Board

Dated: January 18, 2021

Published in: Herald News  
Bergen Record

On File with the Passaic County Clerk

**Louis E. Imhof III**  
**Clerk of the Board**  
**Board of County Commissioners**  
**County of Passaic**  
**(973) 881-4412 or [Louisi@passaiccountynj.org](mailto:Louisi@passaiccountynj.org)**